



SuperServer<sup>®</sup>  
SYS-221H-TNR  
SYS-221H-TN24R



USER'S MANUAL

Revision 1.1

The information in this User's Manual has been carefully reviewed and is believed to be accurate. The vendor assumes no responsibility for any inaccuracies that may be contained in this document, and makes no commitment to update or to keep current the information in this manual, or to notify any person or organization of the updates. Please Note: For the most up-to-date version of this manual, please see our website at [www.supermicro.com](http://www.supermicro.com).

Super Micro Computer, Inc. ("Supermicro") reserves the right to make changes to the product described in this manual at any time and without notice. This product, including software and documentation, is the property of Supermicro and/or its licensors, and is supplied only under a license. Any use or reproduction of this product is not allowed, except as expressly permitted by the terms of said license.

IN NO EVENT WILL Super Micro Computer, Inc. BE LIABLE FOR DIRECT, INDIRECT, SPECIAL, INCIDENTAL, SPECULATIVE OR CONSEQUENTIAL DAMAGES ARISING FROM THE USE OR INABILITY TO USE THIS PRODUCT OR DOCUMENTATION, EVEN IF ADVISED OF THE POSSIBILITY OF SUCH DAMAGES. IN PARTICULAR, SUPER MICRO COMPUTER, INC. SHALL NOT HAVE LIABILITY FOR ANY HARDWARE, SOFTWARE, OR DATA STORED OR USED WITH THE PRODUCT, INCLUDING THE COSTS OF REPAIRING, REPLACING, INTEGRATING, INSTALLING OR RECOVERING SUCH HARDWARE, SOFTWARE, OR DATA.

Any disputes arising between manufacturer and customer shall be governed by the laws of Santa Clara County in the State of California, USA. The State of California, County of Santa Clara shall be the exclusive venue for the resolution of any such disputes. Supermicro's total liability for all claims will not exceed the price paid for the hardware product.

FCC Statement: This equipment has been tested and found to comply with the limits for a Class A or Class B digital device pursuant to Part 15 of the FCC Rules. These limits are designed to provide reasonable protection against harmful interference when the equipment is operated in industrial environment for Class A device or in residential environment for Class B device. This equipment generates, uses, and can radiate radio frequency energy and, if not installed and used in accordance with the manufacturer's instruction manual, may cause harmful interference with radio communications. Operation of this equipment in a residential area is likely to cause harmful interference, in which case you will be required to correct the interference at your own expense.

California Best Management Practices Regulations for Perchlorate Materials: This Perchlorate warning applies only to products containing CR (Manganese Dioxide) Lithium coin cells. "Perchlorate Material-special handling may apply. See [www.dtsc.ca.gov/hazardouswaste/perchlorate](http://www.dtsc.ca.gov/hazardouswaste/perchlorate)".



WARNING: This product can expose you to chemicals including lead, known to the State of California to cause cancer and birth defects or other reproductive harm. For more information, go to [www.P65Warnings.ca.gov](http://www.P65Warnings.ca.gov).

The products sold by Supermicro are not intended for and will not be used in life support systems, medical equipment, nuclear facilities or systems, aircraft, aircraft devices, aircraft/emergency communication devices or other critical systems whose failure to perform be reasonably expected to result in significant injury or loss of life or catastrophic property damage. Accordingly, Supermicro disclaims any and all liability, and should buyer use or sell such products for use in such ultra-hazardous applications, it does so entirely at its own risk. Furthermore, buyer agrees to fully indemnify, defend and hold Supermicro harmless for and against any and all claims, demands, actions, litigation, and proceedings of any kind arising out of or related to such ultra-hazardous use or sale.

Manual Revision 1.1

Release Date: March 21, 2024

Unless you request and receive written permission from Super Micro Computer, Inc., you may not copy any part of this document. Information in this document is subject to change without notice. Other products and companies referred to herein are trademarks or registered trademarks of their respective companies or mark holders.

Copyright © 2024 by Super Micro Computer, Inc.  
All rights reserved.

**Printed in the United States of America**

# Preface

## About this Manual

This manual is written for professional system integrators and PC technicians. It provides information for the installation and use of the server. Installation and maintenance should be performed by certified service technicians only.

Please refer to the SYS-221H-T Series server specifications page on our website for updates on supported memory, processors, and operating systems (<http://www.supermicro.com>).

## Notes

For your system to work properly, please follow the links below to download all necessary drivers/utilities and the user's manual for your server.

- Supermicro product manuals: <http://www.supermicro.com/support/manuals/>
- Product drivers and utilities: <https://www.supermicro.com/wdl>
- Product safety info: [http://www.supermicro.com/about/policies/safety\\_information.cfm](http://www.supermicro.com/about/policies/safety_information.cfm)

If you have any questions, please contact our support team at:  
[support@supermicro.com](mailto:support@supermicro.com)

This manual may be periodically updated without notice. Please check the Supermicro website for possible updates to the manual revision level.

## Secure Data Deletion

A secure data deletion tool designed to fully erase all data from storage devices can be found on our website: [https://www.supermicro.com/about/policies/disclaimer.cfm?url=/wdl/utility/Log9\\_Secure\\_Data\\_Deletion\\_UTILITY/](https://www.supermicro.com/about/policies/disclaimer.cfm?url=/wdl/utility/Log9_Secure_Data_Deletion_UTILITY/)

## Warnings

Special attention should be given to the following symbols used in this manual.



**Warning!** Indicates important information given to prevent equipment/property damage or personal injury.



**Warning!** Indicates high voltage may be encountered when performing a procedure.

# Contents

Contacting Supermicro.....	9
<b>Chapter 1 Introduction</b>	
1.1 Overview.....	10
1.2 System Features .....	11
SYS-221H-TN24R Front View .....	11
SYS-221H-TNR Front View .....	12
Control Panel.....	13
Rear View.....	14
1.3 System Architecture .....	16
Main Components .....	16
System Block Diagrams.....	18
SYS-221H-TNR .....	18
SYS-221H-TN24R .....	19
1.4 Motherboard Layout .....	20
Quick Reference Table.....	21
<b>Chapter 2 Server Installation</b>	
2.1 Overview.....	23
2.2 Unpacking the System .....	23
2.3 Preparing for Setup.....	23
Choosing a Setup Location.....	23
Rack Precautions .....	24
Server Precautions.....	24
Rack Mounting Considerations .....	24
Ambient Operating Temperature.....	24
Airflow .....	25
Mechanical Loading.....	25
Circuit Overloading .....	25
Reliable Ground.....	25
2.4 Particulate and Gaseous Contamination Limits.....	26
Particulate Contamination Specifications.....	26
Gaseous Contamination Specifications .....	26

2.5	Installing the Rails .....	27
	Identifying the Rails .....	27
	Releasing the Inner Rail.....	28
	Installing the Inner Rails .....	29
	Installing the Outer Rails onto the Rack.....	30
2.6	Installing the Chassis into a Rack.....	31
	Removing the Chassis from the Rack .....	32
<b>Chapter 3 Maintenance and Component Installation</b>		
3.1	Removing Power .....	33
3.2	Accessing the System.....	34
	Removing the Top Cover.....	34
3.3	Static-Sensitive Devices.....	35
	Precautions .....	35
	Unpacking .....	35
3.4	Processor and Heatsink Installation.....	36
	The 4th and 5th Gen Intel Xeon Scalable Processor .....	37
	Overview of the CPU Socket .....	40
	Overview of the Processor Carrier Assembly .....	41
	Overview of the Processor Heatsink Module (PHM) .....	42
	Creating the Processor Carrier Assembly.....	45
	Creating the Processor Heatsink Module (PHM).....	49
	Preparing the CPU Socket for Installation .....	50
	Preparing to Install the PHM into the CPU Socket.....	51
	Installing the PHM into the CPU Socket.....	53
	Removing the PHM from the CPU Socket .....	55
	Removing the Processor Carrier Assembly from the PHM .....	56
	Removing the Processor from the Processor Carrier Assembly .....	57
	Installing EVAC Heatsinks (Optional).....	58
3.5	Memory Support and Installation .....	60
	Memory Support.....	60
	DDR5 Memory Support for 4 <sup>th</sup> and 5 <sup>th</sup> Gen Intel Xeon Scalable Processors.....	60
	Memory Population Table for 4 <sup>th</sup> and 5 <sup>th</sup> Gen Intel Xeon Scalable Processors .....	63

Memory Population Guidelines .....	65
Guidelines Regarding Mixing DIMMs .....	65
DIMM Construction .....	65
DIMM Installation .....	66
DIMM Removal .....	66
3.6 Motherboard Battery.....	67
Battery Removal.....	67
Proper Battery Disposal .....	67
Battery Installation.....	67
3.7 Storage Drives.....	68
Hot-Swap for NVMe Drives.....	69
3.8 System Cooling .....	70
Fans .....	70
Air Shrouds .....	71
3.9 Expansion Cards.....	72
Expansion Card Slot Configurations .....	72
Installing Expansion Cards .....	73
3.10 AIOM Network Cards .....	74
3.11 Cable Routing Diagrams .....	75
SYS-221H-TNR Storage Cables - NVMe .....	75
SYS-221H-TN24R Storage Cables - NVMe .....	76
SYS-221H-TNR Storage Cables - SAS/SATA .....	77
SYS-221H-TN24R Storage Cables - SAS/SATA .....	78
PCIe Cables - Expansion Card Slots.....	79
PCIe Cables - Expansion Card Slots.....	80
PCIe Cables - AIOM/OCP 3.0 NIC Slots .....	81
I/O Board Cable .....	82
Power Cables.....	83
3.12 Power Supply .....	84
<b>Chapter 4 Motherboard Connections</b>	
4.1 Power Connections .....	85
4.2 Headers and Connectors .....	87
Control Panel.....	91
4.3 Input/Output Ports .....	95
4.4 LED Indicators.....	98

---



---

## **Chapter 5 Software**

5.1 Microsoft Windows OS Installation.....	99
5.2 Driver Installation.....	101
5.3 BMC.....	102
5.4 Logging into the BMC (Baseboard Management Controller) .....	102

## **Chapter 6 Optional Components**

6.1 Storage Protocols Supported .....	103
6.2 Configuration Ordering Information .....	104
Hyper 2U SYS-221H-TNR Drive Bay Configuration Options .....	104
Hyper 2U SYS-221H-TNR PCIe Slot Configuration Options.....	106
Hyper 2U SYS-221H-TN24R Drive Bay Configuration Options .....	109
Hyper 2U SYS-221H-TN24R PCIe Slot Configuration Options.....	113
For Drive Bay Configuration Option 1 (24 NVMe) .....	113
For Drive Bay Configuration Option 2 & 3 (16 NVMe +8 SAS or SATA).....	116
For Drive Bay Configuration Options excluding 24 NVMe & 16 NVMe.....	118
6.3 Power Supply Configurations.....	120
6.4 Cable Management Arm.....	120
6.5 TPM Security Module.....	122
6.6 Intel Virtual RAID on CPU (VROC).....	123
Requirements and Restrictions .....	123
Supported SSDs and Operating Systems .....	123
Additional Information .....	124
Hardware Key .....	124
Configuring Intel VMD .....	125
Configuring VMD Manually.....	125
Creating NVMe RAID Configurations.....	131
Status Indications.....	132
Hot-Swap Drives .....	132
Hot-unplug .....	132
Hot-plug .....	132
Related Information Links .....	132
6.7 GPUs.....	133
Installing GPUs .....	133
Storing the Air Blocks for 1U GPU Air Shrouds .....	136

---



---

## ***Chapter 7 Troubleshooting and Support***

7.1 Information Resources .....	138
Website .....	138
Direct Links for the SYS-221H-T Series System .....	138
Direct Links for General Support and Information .....	138
7.2 BMC Interface .....	139
7.3 Troubleshooting Procedures .....	140
Before Power On .....	140
No Power .....	140
No Video .....	140
System Boot Failure .....	140
Memory Errors .....	141
Losing the System's Setup Configuration .....	141
When the System Becomes Unstable .....	141
7.4 CMOS Clear .....	143
7.5 Where to Get Replacement Components .....	143
7.6 Technical Support Procedures .....	144
Returning Merchandise for Service .....	145
7.7 BIOS POST Codes .....	145
7.8 Feedback .....	145
7.9 Contacting Supermicro .....	146
<b><i>Appendix A Standardized Warning Statements for AC Systems</i></b>	
<b><i>Appendix B System Specifications</i></b>	
BSMI/RoHS .....	170



## Contacting Supermicro

### Headquarters

Address: Super Micro Computer, Inc.  
980 Rock Ave.  
San Jose, CA 95131 U.S.A.

Tel: +1 (408) 503-8000

Fax: +1 (408) 503-8008

Email: [marketing@supermicro.com](mailto:marketing@supermicro.com) (General Information)  
[Sales-USA@supermicro.com](mailto:Sales-USA@supermicro.com) (Sales Inquiries)  
[Government\\_Sales-USA@supermicro.com](mailto:Government_Sales-USA@supermicro.com) (Gov. Sales Inquiries)  
[support@supermicro.com](mailto:support@supermicro.com) (Technical Support)  
[RMA@supermicro.com](mailto:RMA@supermicro.com) (RMA Support)  
[Webmaster@supermicro.com](mailto:Webmaster@supermicro.com) (Webmaster)

Website: [www.supermicro.com](http://www.supermicro.com)

### Europe

Address: Super Micro Computer B.V.  
Het Sterrenbeeld 28, 5215 ML  
's-Hertogenbosch, The Netherlands

Tel: +31 (0) 73-6400390

Fax: +31 (0) 73-6416525

Email: [Sales\\_Europe@supermicro.com](mailto:Sales_Europe@supermicro.com) (Sales Inquiries)  
[Support\\_Europe@supermicro.com](mailto:Support_Europe@supermicro.com) (Technical Support)  
[RMA\\_Europe@supermicro.com](mailto:RMA_Europe@supermicro.com) (RMA Support)

Website: [www.supermicro.nl](http://www.supermicro.nl)

### Asia-Pacific

Address: Super Micro Computer, Inc.  
3F, No. 150, Jian 1st Rd.  
Zhonghe Dist., New Taipei City 235  
Taiwan (R.O.C)

Tel: +886-(2) 8226-3990

Fax: +886-(2) 8226-3992

Email: [Sales-Asia@supermicro.com.tw](mailto:Sales-Asia@supermicro.com.tw) (Sales Inquiries)  
[Support@supermicro.com.tw](mailto:Support@supermicro.com.tw) (Technical Support)  
[RMA@supermicro.com.tw](mailto:RMA@supermicro.com.tw) (RMA Support)

Website: [www.supermicro.com.tw](http://www.supermicro.com.tw)

# Chapter 1

## Introduction

### 1.1 Overview

This chapter provides a brief outline of the functions and features of the SuperServer SYS-221H-T Series. The system provides flexible storage configurations using a backplane that supports 24 drives or up to two backplanes each supporting eight drives. In addition, storage can be provided by adapter cards or the onboard PCH.

The following provides an overview of the specifications and capabilities of the SYS-221H-T Series.

System Overview	
<b>Motherboard</b>	X13DEM
<b>Chassis</b>	CSE-HS219-R1K24P and CSE-HS219-R1K63P
<b>Processor Support</b>	Supports dual 4 <sup>th</sup> and 5 <sup>th</sup> Gen Intel Xeon Scalable Processors (in Socket E LGA 4677) with four UPIs (20 GT/s max.) and a thermal design power (TDP) up to 350 W SP XCC, SP MCC, and Max Series (HBM) SKUs supported
<b>Memory</b>	Supports up to 8 TB 3DS RDIMM/RDIMM DDR5 ECC memory in 32 DIMM slots - 4 <sup>th</sup> Gen CPU: speeds of up to 4800 MT/s (1DPC) and up to 4400 MT/s (2DPC) - 5 <sup>th</sup> Gen CPU: speeds of up to 5600 MT/s (1DPC) and up to 4400 MT/s (2DPC) <b>Note:</b> Memory speed/capacity support depends on the processors used in the system.)
<b>Drive Support</b>	SYS-221H-TNR: eight NVMe/SATA/SAS drive bays (optional configuration for sixteen NVMe/SATA/SAS drive bays) SYS-221H-TN24R: 24 NVMe/SATA/SAS drive bays Both systems: two M.2 NVMe or two M.2 SATA3 slots on the motherboard
<b>Expansion Slots</b>	Optional eight PCIe 5.0 x8 slots or four PCIe 5.0 x16 slots (see <a href="#">Section 3.9</a> for details)
<b>I/O Ports</b>	One OCP 3.0 compatible slim AIOM slot (second slot optional) One RJ45 dedicated BMC LAN port Two rear USB 2.0 ports One VGA port
<b>System Cooling</b>	Four 8-cm heavy duty hot-swap fans with optimal fan speed control Two air shrouds
<b>Power</b>	SYS-221H-TNR: two 1200 W (Titanium Level 96%) redundant power supplies SYS-221H-TN24R: two 1600 W (Titanium Level 96%) redundant power supplies
<b>Form Factor</b>	2U Rackmount 1.7 x 17.2 x 29.3 in. / 43 x 437 x 746 mm (H x W x D)

**Notes:** A Quick Reference Guide can be found on the [product page](#) of the Supermicro website. The following safety models associated with the SYS-221H-T Series have been certified as compliant with UL or CSA: HS219-R12X13, HS219-12, HS219-R16X13, HS219-16, HS219-R24X13, HS219-24, HS219-R26X13, HS219-26, HS219-R13DX13, HS219-13D, HS219-R16DX13, HS219-16D, and HS219-R20X13.

## 1.2 System Features

The following views of the system display the main features. Refer to [Appendix B](#) for additional specifications.

### SYS-221H-TN24R Front View



Figure 1-1. SYS-221H-TN24R Front View

System Features: Front	
Feature	Description
Control Panel	One control panel (see <a href="#">Control Panel</a> for details)
Service Tag	Service Tag with <a href="#">BMC Password Reset</a>

Logical Storage Drive Numbers	
Item	Description
0 _ 23	24 hot-swap 2.5" NVMe/SATA3/SAS3* drive bays

\*NVMe, SATA3, or SAS3 support requires additional parts in [optional parts list](#).

## SYS-221H-TNR Front View



Figure 1-2. SYS-221H-TNR Front View

System Features: Front	
Feature	Description
Control Panel	One control panel (see <a href="#">Control Panel</a> for details)
Service Tag	Service Tag with <a href="#">BMC Password Reset</a>

Logical Storage Drive Numbers	
Item	Description
0 _ 7	Storage module supports eight hot-swap 2.5" NVMe/SATA3/SAS3* drive bays

\*NVMe, SATA3, or SAS3 support requires additional parts in [optional parts list](#).

## Control Panel

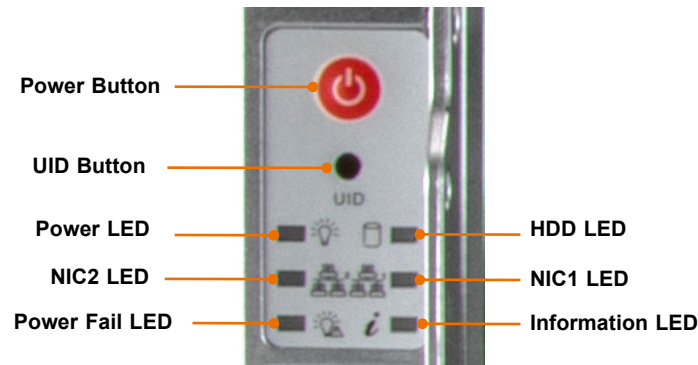


Figure 1-3. Control Panel

Control Panel Features	
Feature	Description
Power Button	The main power button is used to apply or remove power from the power supply to the server. Turning off system power with this button removes the main power but maintains standby power. To perform many maintenance tasks, you must also unplug the system before servicing.
UID Button	Press and hold the button to toggle the UID function in the information LED. Reset— Press and hold the button. After 6 seconds, the BMC resets. Restore factory default configuration— Hold the button for 12 seconds.
Power LED	Steady on: DC power (Main Power) on Blinking at 4 Hz – Checking BIOS/BMC integrity Blinking at 4 Hz and "i" LED is blue – BIOS firmware updating Two blinks at 4 Hz, one pause 2 Hz and "i" LED blue – BMC firmware updating
HDD LED	Indicates activity on a PCH connected storage device (SATA drives and M.2 SATA) when flashing.
NIC2 LED	Indicates network activity on even numbered LAN ports. A1 (ports 2 & 4) and A2 (ports 2 & 4).
NIC1 LED	Indicates network activity on odd numbered LAN ports. A1 (ports 1 & 3) and A2 (ports 1 & 3).
Power Fail LED	Indicates a power supply module has failed.
Universal Information LED	See table below for details.

Information LED	
Color, Status	Description
Red, solid	An overheat condition has occurred.
Red, blinking at 1 Hz	Fan failure, check for an inoperative fan.
Red, blinking at 0.25 Hz	Power failure, check for a non-operational power supply.
Red, solid, with Power LED blinking green	Fault detected
Blue and red, blinking at 10 Hz	Recovery mode
Blue, solid	UID has been activated locally to locate the server in a rack environment.
Blue, blinking at 1 Hz	UID has been activated using the BMC to locate the server in a rack environment.
Blue, blinking at 2 Hz	BMC is resetting
Blue, blinking at 4 Hz	BMC is setting factory defaults
Blue, blinking at 10 Hz with Power LED blinking green	BMC/BIOS firmware is updating

## Rear View

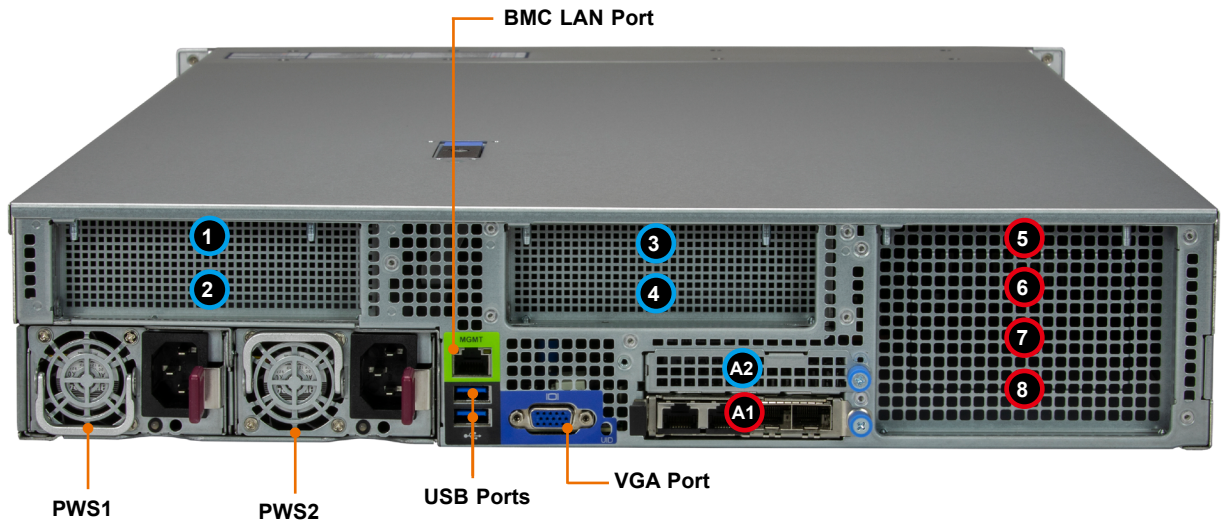


Figure 1-4. System: Rear View

System Features: Rear	
Feature	Description
Power Supplies	Two redundant power supply modules, PWS1 on the left, PWS2 on the right
USB	Two USB 2.0 ports
BMC LAN	One RJ45 dedicated BMC LAN port
VGA	One VGA port
<b>A1</b>	AIOM/OCP NIC 3.0 Slot
<b>A2</b>	Optional AIOM/OCP NIC 3.0 Slot
<b>1</b> to <b>4</b>	1 - Optional: PCIe 5.0 x8 (in x16) slot or PCIe 5.0 x16 slot (FH, 10.5"L) 2 - Optional: PCIe 5.0 x8 (in x16) slot (FH, 10.5"L) 3 - Optional: PCIe 5.0 x8 (in x16) slot or PCIe 5.0 x16 slot (FH, 10.5"L) 4 - Optional: PCIe 5.0 x8 (in x16) slot (FH, 10.5"L)
<b>5</b> to <b>8</b>	5 - Optional: PCIe 5.0 x8 (in x16) slot or PCIe 5.0 x16 slot (FH, 10.5"L) 6 - Optional: PCIe 5.0 x8 (in x16) slot (FH, 10.5"L) 7 - Optional: PCIe 5.0 x8 (in x16) slot or PCIe 5.0 x16 slot (FH, 10.5"L) 8 - Optional: PCIe 5.0 x8 (in x16) slot (FH, 10.5"L)

CPU1 ■ CPU2 ■

<b>Power Supply Indicators</b>		
<b>Power Supply Condition</b>	<b>Green LED</b>	<b>Amber LED</b>
No AC Power to Power Supply	OFF	OFF
Power Supply critical events causing a shutdown/ failure/ OCP/ OVP/ Fan Fail/ OTP/ UVP	OFF	Amber LED
Power Supply Warning Events Where the power supply continues to operate; High temperature; Over voltage; under voltage, etc.	OFF	1 Hz Blink Amber
AC present only 12VSB ON (PS OFF)	1 Hz Blink Green	OFF
Output ON and OK	Green	OFF
AC cord unplugged and in redundant mode	OFF	Amber

## 1.3 System Architecture

This section covers the locations of the system's main components, a system block diagram, and a motherboard layout with the connectors and jumpers called out.

### Main Components

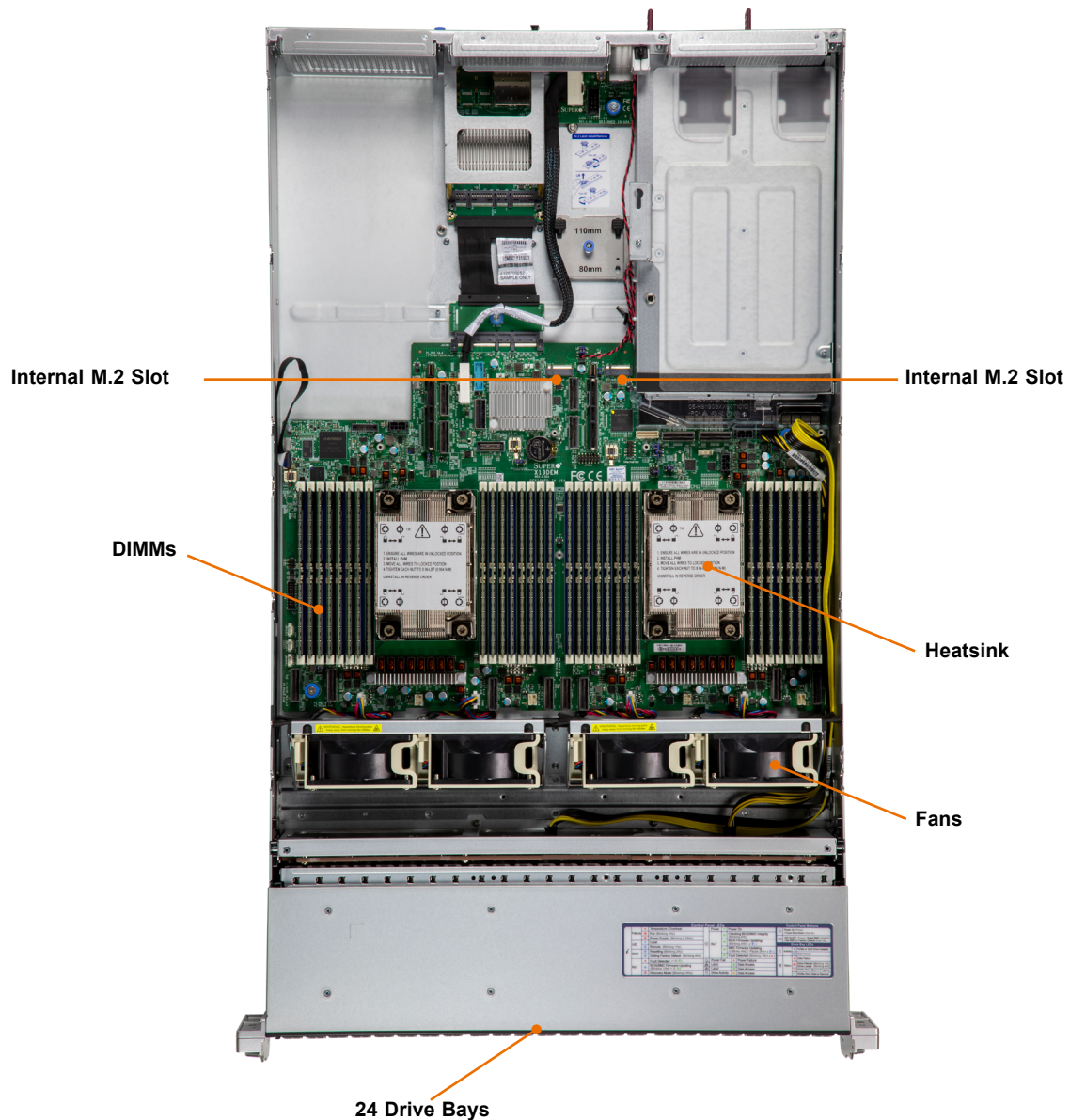


Figure 1-4. Main Component Locations



System Features: Top	
Feature	Description
Power Supply	SYS-221H-TNR: dual redundant modules, PWS-1K24A-1R SYS-221H-TN24R: dual redundant modules, PWS-1K63A-1R
DIMM slots	32 DIMM memory slots
Processors	Supports dual 4 <sup>th</sup> and 5 <sup>th</sup> Gen Intel Xeon Scalable Processors (in Socket E LGA 4677) with four UPIs (20 GT/s max.) and a thermal design power (TDP) up to 350 W SP XCC, SP MCC, and Max Series (HBM) SKUs supported
System Fans	Four 8-cm dual counter-rotating PWM fans, FAN-0223L4
Service Tag	Service tag with serial number / BMC ADMIN password
Backplane	SYS-221H-TNR: eight SAS3/SATA3/NVMe5 storage device backplane, BPN-NVME5-HS219N-S8 SYS-221H-TN24R: 24 SAS3/SATA3/NVMe5 storage device backplane, BPN-NVME5-HS219N-S24



## SYS-221H-TN24R

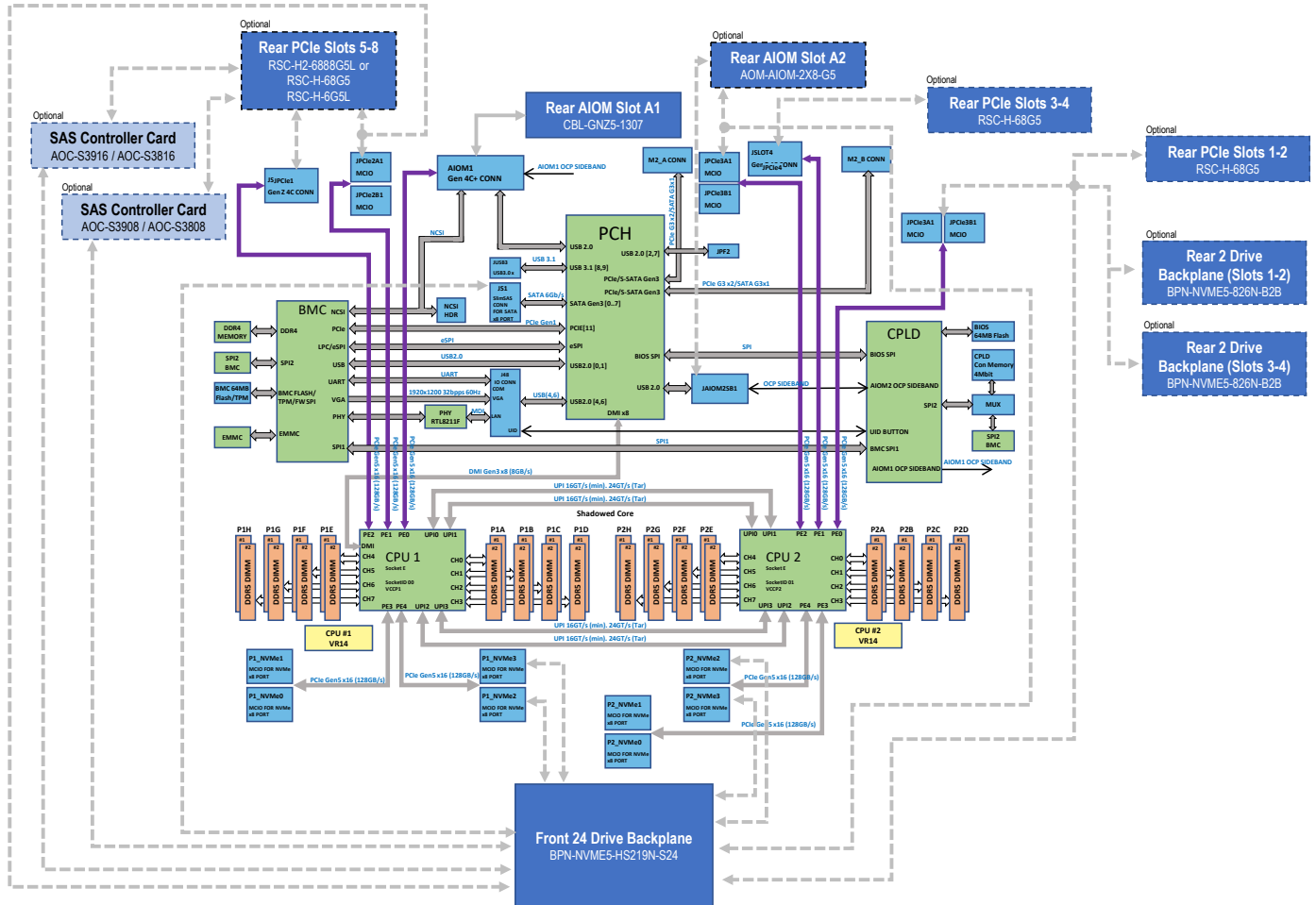


Figure 1-5. SYS-221H-TN24R Block Diagram

**Note:** This is a general block diagram and may not exactly represent the features on your system. See the previous pages for the actual specifications of your system.

## 1.4 Motherboard Layout

Below is a layout of the X13DEM motherboard with a jumper, connector, and LED locations shown. See the table on the following page for descriptions. For detailed descriptions, pinout information, and jumper settings, refer to [Chapter 4](#) or the [Motherboard Manual](#).

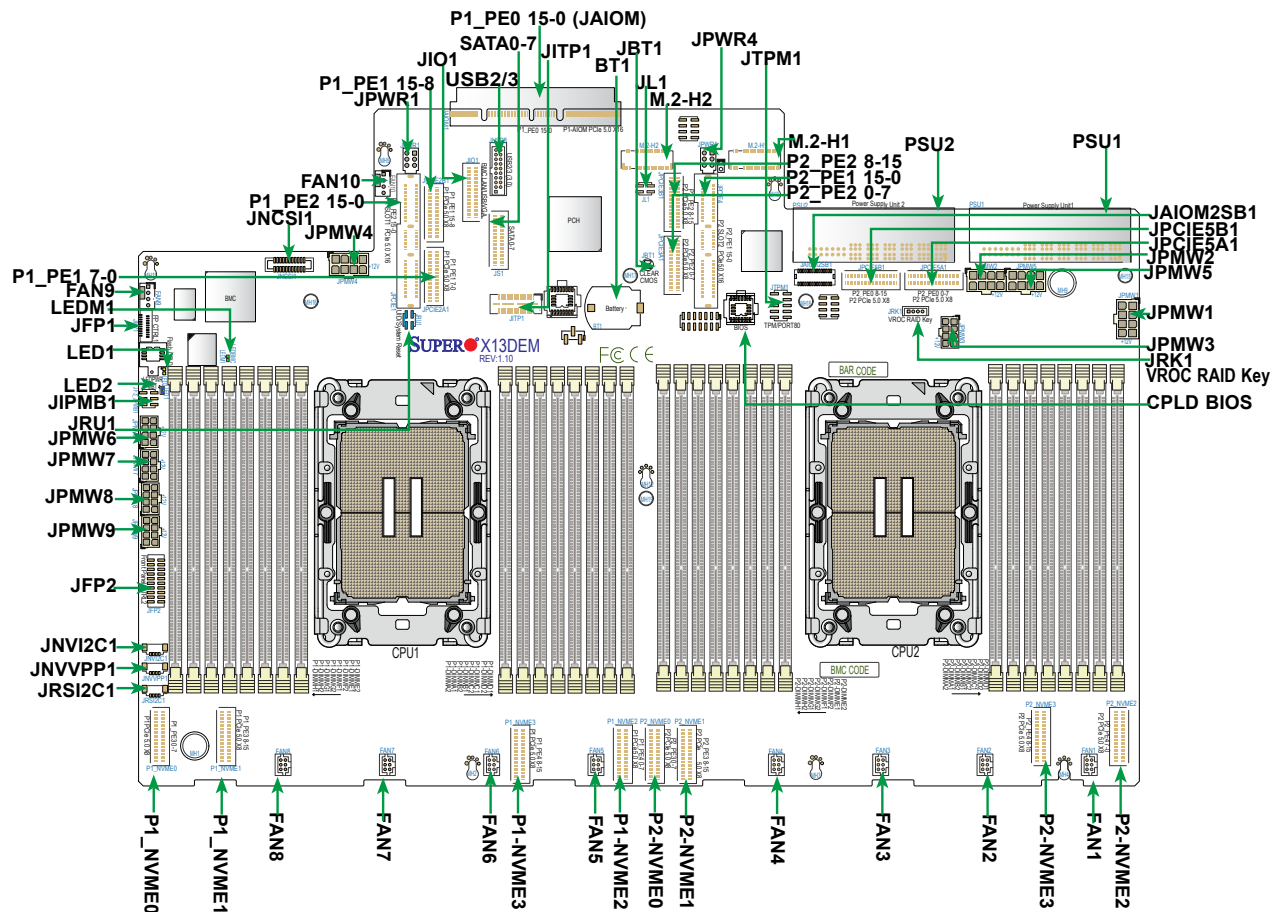


Figure 1-6. Motherboard Layout

### Notes:

- "■" indicates the location of Pin 1.
- Jumpers/LED indicators not indicated are used for testing only.
- Use only the correct type of onboard CMOS battery as specified by the manufacturer. Do not install the onboard battery upside down to avoid a possible explosion.

## Quick Reference Table

Jumper	Description	Default Setting
JBT1	CMOS Clear	Open (Normal)
JRU1	UID LED/System Reset Jumper	Pins 1/2: UID LED (Default), Pins 3/4: System Reset
LED	Description	Status
LED1 (UID-LED)	Unit Identifier (UID) LED	Solid Blue: Unit Identified
LED2 (LEDPWR)	Power LED	LED On: Onboard Power On
LEDBMC (LEDM1)	BMC Heartbeat LED	Blinking Green: BMC Normal (Active), Solid Green: (During BMC Reset or during a Cold Reboot)
Connector	Description	
Battery (BT1)	Onboard battery	
BMCLAN/USB/VGA (JIO1)	Low-profile (LP) Slim SAS I/O connector used for dedicated BMC LAN/USB/VGA connections	
FAN1-FAN8, FAN9/FAN10	Eight 6-pin cooling fan headers (FAN1~FAN 8) and two 4-pin cooling fan headers (FAN9-FAN10)	
JAIOM1 (P1_PE0 15-0)	Supermicro Advanced input/output Module (AIOM) PCIe 5.0 x16 connector for rear I/O support	
JAIOM2SB1	Supermicro Advanced Input/Output Module (AIOM2) sideband connector	
JFP1	Front Control Panel header	
JFP2	Front Control Panel header with USB and VGA support	
JPMW1 - JPMW9	+12 V power connectors 1~9	
JPWR1 and JPWR4	6-pin power connectors	
PS1/PS2	Power Supply Unit1/Power Supply Unit2 for system power use (See Note 1 below.)	
JIPMB1 (JF3_JIPMB1)	6-pin BMC external I <sup>2</sup> C header	
JL1	Chassis Intrusion header	
JNCSI1	NC-SI (Network Controller Sideband Interface) connector (See Note 2 below.)	
JNVI2C1	NVMe SMBus I <sup>2</sup> C header used for PCIe SMBus clock and data connections with hot-plug support.	
JNVVPP1	NVMe VPP SMBus (System Management Bus) with hot-plug support	
JTPM1	Trusted Platform Module/Port 80 connector	
JRSI2C1	Auxiliary I <sup>2</sup> C header used for PCIe cards to allow the BMC/BIOS to read information from internal drives or FRUs (Field Replace Units) effectively	

**Note 1:** Refer to the table below for the power supplies that support the main power supply units (PS1/PS2) in Supermicro hyper servers. For detailed power supply support for your particular server, please refer to your hyper server user manual.

PWS-2K08F-1R (AC 2000W)	PWS-1K30F-1R (DC 1300W)	PWS-1K24A-1R (AC 1200W)
PWS-1K63A-1R (AC 1600W)	PWS-2K07A-1R (AC 2000W)	PWS-2K63A-1R (AC 2600W)
PWS-1K31D-1R (DC 1300W)	PWS-1K60D-1R (DC 1600W)	

**Note 2:** For details on how to configure Network Interface Card (NIC) settings, please refer to the Network Interface Card Configuration User's Guide posted on our website under the link: <https://www.supermicro.com/support/manuals/>.

M.2-H1/M.2-H2	PCIe 3.0 x2/SATA3 Hybrid M.2 slots (with support of M-Key 2280, and 22110)
MH1/MH9	Mounting holes for built-in thumbscrews used to securely attach the motherboard to the chassis (Refer to the motherboard layout for mounting hole detailed information.)
MH2/MH3/MH4/MH5/ MH10/MH11/MH12	Mounting holes for T-pins used to help lock the motherboard to the proper location in the chassis (Refer to the motherboard layout for mounting hole detailed information.)
MH15 - MH19	Mounting holes for standoffs used for heatsink support (Refer to the motherboard layout for mounting hole detailed information.)
P1_NVME 0-3	(P1) PCIe 5.0 x8 MCIO connectors supported by CPU1 with four NVMe connections (0/1/2/3)
P2_NVME 0-3	(P2) PCIe 5.0 x8 MCIO connectors supported by CPU2 with four NVMe connections (0/1/2/3)
P1_PE0 15-0 (JAIOM1)	PCIe 5.0 x16 AIOM (OCP3.0-compliant) slot supported by CPU1
P1_PE1 7-0 (JPCIE2A1)	(P1) PCIe 5.0 x8 MCIO connector
P1_PE1 15-8 (JPCIE2B1)	(P1) PCIe 5.0 x8 MCIO connector supported by CPU1
P1_PE2 15-0 (JPCIE1)	(P1-SLOT1) PCIe 5.0 x16 slot supported by CPU1
P2_PE0 0-7 (JPCIE5A1)	(P2) PCIe 5.0 x8 MCIO connector supported by CPU2
P2_PE0 8-15 (JPCIE5B1)	(P2) PCIe 5.0 x8 MCIO connector supported by CPU2
P2_PE1 15-0 (JPCIE4)	(P2-SLOT2) PCIe 5.0 x16 slot supported by CPU2
P2_PE2 0-7 (JPCIE3A1)	(P2) PCIe 5.0 x8 MCIO connector supported by CPU2
P2_PE2 8-15 (JPCIE3B1)	(P2) PCIe 5.0 x8 MCIO connector supported by CPU2
SATA 0-7 (JS1)	SlimSAS LP (MCIO) connector with support for eight Intel® PCH SATA 3.0 connections (RAID 0, RAID 1, RAID 5, and RAID 10 supported)
USB2/3 (3.2) (JUSB3)	Rear USB header with support for two USB 3.2 Gen1 ports
VROC RAID Key (JRK1)	Intel VROC key header for NVMe RAID support (See the note below.)

**Note:** For detailed instructions on how to configure VROC RAID settings, please refer to the VROC RAID Configuration User's Guide posted on the webpage under the link: <http://www.supermicro.com/support/manuals/>.

# Chapter 2

## Server Installation

### 2.1 Overview

This chapter provides advice and instructions for mounting your system in a server rack. If your system is not already fully integrated with processors, system memory, etc., refer to [Chapter 3](#) for details on installing those specific components.

**Caution:** Electrostatic Discharge (ESD) can damage electronic components. To prevent such damage to PCBs (printed circuit boards), it is important to use a grounded wrist strap, handle all PCBs by their edges and keep them in anti-static bags when not in use.

### 2.2 Unpacking the System

Inspect the box in which the system was shipped, and note if it was damaged in any way. If any equipment appears damaged, file a damage claim with the carrier who delivered it.

Decide on a suitable location for the rack unit that will hold the server. It should be situated in a clean, dust-free area that is well ventilated. Avoid areas where heat, electrical noise, and electromagnetic fields are generated. It will also require a grounded AC power outlet nearby. Be sure to read the precautions and considerations noted or in [Appendix A](#).

### 2.3 Preparing for Setup

The box in which the system was shipped should include the rackmount hardware needed to install it into the rack. Please read this section in its entirety before you begin the installation.

#### Choosing a Setup Location

- The system should be situated in a clean, dust-free area that is well ventilated. Avoid areas where heat, electrical noise, and electromagnetic fields are generated.
- Leave enough clearance in front of the rack so that you can open the front door completely (~25 inches) and approximately 30 inches of clearance in the back of the rack to allow sufficient space for airflow and access when servicing.
- This product should be installed only in a Restricted Access Location (dedicated equipment rooms, service closets, etc.).

- This product is not suitable for use with visual display workplace devices according to §2 of the German Ordinance for Work with Visual Display Units.

## **Rack Precautions**

- Ensure that the leveling jacks on the bottom of the rack are extended to the floor so that the full weight of the rack rests on them.
- In single rack installations, stabilizers should be attached to the rack. In multiple rack installations, the racks should be coupled together.
- Always make sure the rack is stable before extending a server or other component from the rack.
- You should extend only one server or component at a time - extending two or more simultaneously may cause the rack to become unstable.

## **Server Precautions**

- Review the electrical and general safety precautions in [Appendix A](#).
- Determine the placement of each component in the rack before you install the rails.
- Install the heaviest server components at the bottom of the rack first and then work your way up.
- Use a regulating uninterruptible power supply (UPS) to protect the server from power surges and voltage spikes and to keep your system operating in case of a power failure.
- Allow any drives and power supply modules to cool before touching them.
- When not servicing, always keep the front door of the rack and all covers/panels on the servers closed to maintain proper cooling.

## **Rack Mounting Considerations**

### ***Ambient Operating Temperature***

If installed in a closed or multi-unit rack assembly, the ambient operating temperature of the rack environment may be greater than the room's ambient temperature. Therefore, consideration should be given to installing the equipment in an environment compatible with the manufacturer's maximum rated ambient temperature (TMRA).



### ***Airflow***

Equipment should be mounted into a rack so that the amount of airflow required for safe operation is not compromised.

### ***Mechanical Loading***

Equipment should be mounted into a rack so that a hazardous condition does not arise due to uneven mechanical loading.

### ***Circuit Overloading***

Consideration should be given to the connection of the equipment to the power supply circuitry and the effect that any possible overloading of circuits might have on overcurrent protection and power supply wiring. Appropriate consideration of equipment nameplate ratings should be used when addressing this concern.

### ***Reliable Ground***

A reliable ground must be maintained at all times. To ensure this, the rack itself should be grounded. Particular attention should be given to power supply connections other than the direct connections to the branch circuit (i.e. the use of power strips, etc.).



To prevent bodily injury when mounting or servicing this unit in a rack, you must take special precautions to ensure that the system remains stable. The following guidelines are provided to ensure your safety:

- This unit should be mounted at the bottom of the rack if it is the only unit in the rack.
- When mounting this unit in a partially filled rack, load the rack from the bottom to the top with the heaviest component at the bottom of the rack.
- If the rack is provided with stabilizing devices, install the stabilizers before mounting or servicing the unit in the rack.
- Slide rail mounted equipment is not to be used as a shelf or a workspace.



Slide rail mounted equipment is not to be used as a shelf or a workspace.



**Warning:** Do not pick up the server with the front handles. They are designed to pull the system from a rack only.

## 2.4 Particulate and Gaseous Contamination Limits

Data centers should meet the following requirements to maintain proper air quality.

### Particulate Contamination Specifications

All sources of dust inside data centers should be reduced or eliminated. Dust having a deliquescent relative humidity of less than the maximum allowable relative humidity should be filtered out.

The cleanliness of data centers must adhere to ISO Standard 14644-1 Class 8 (ISO 2015) to be within 95% of the levels specified below:

1. Each cubic meter of air should contain no more than 3,520,000 particles that are equal to or greater than 0.5  $\mu\text{m}$  in diameter.
2. Each cubic meter of air should contain no more than 832,000 particles that are equal to or greater than 1  $\mu\text{m}$  in diameter.
3. Each cubic meter of air should contain no more than 29,300 particles that are equal to or greater than 5  $\mu\text{m}$  in diameter.

This level of cleanliness can generally be achieved by an appropriate filtration scheme as outlined below:

1. The room air should be continuously filtered with MERV 8 filters, as recommended by AHRI Standard 1360 (2017).
2. The air entering the data center should be filtered with MERV 11 to MERV 13 filters.

### Gaseous Contamination Specifications

The total gaseous contamination, i.e., copper and silver corrosion rates, should not exceed ANSI/ISA Standard 71.04-2013, severity level G1 (mild) as described below:

1. A copper reactivity rate of less than 300  $\text{\AA}/\text{month}$ .
2. A silver reactivity rate of less than 200  $\text{\AA}/\text{month}$ .

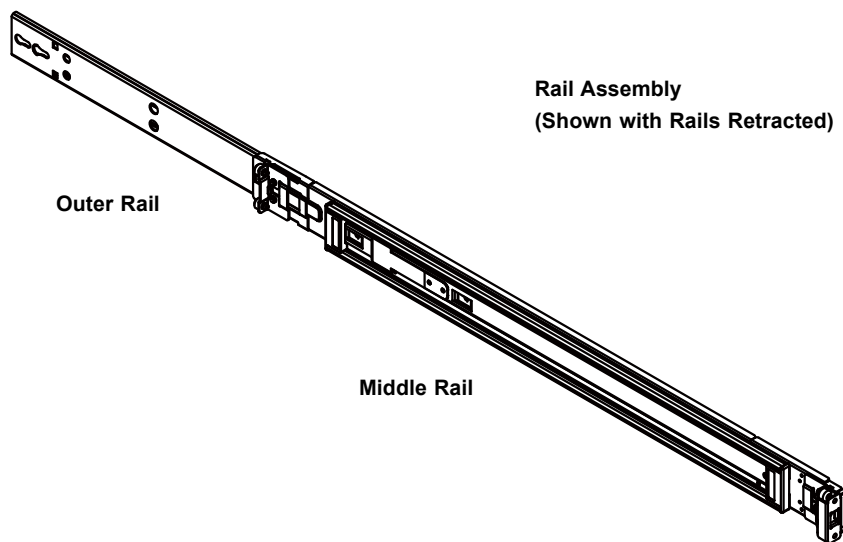
## 2.5 Installing the Rails

This section provides information on installing the chassis into a rack unit with the rails provided. There are a variety of rack units on the market, which may mean that the assembly procedure will differ slightly from the instructions provided. You should also refer to the installation instructions that came with the rack unit you are using.

**Note:** This rail will fit a rack between 26.8" and 36.4" deep.

### Identifying the Rails

The chassis package includes two rail assemblies. Each assembly consists of three sections: An inner rail that secures directly to the chassis, an outer rail that secures to the rack, and a middle rail which extends from the outer rail. These assemblies are specifically designed for the left and right side of the chassis and labeled.



**Figure 2-1. Identifying the Outer Rail, Middle Rail, and Inner Rail (Left Rail Assembly Shown)**

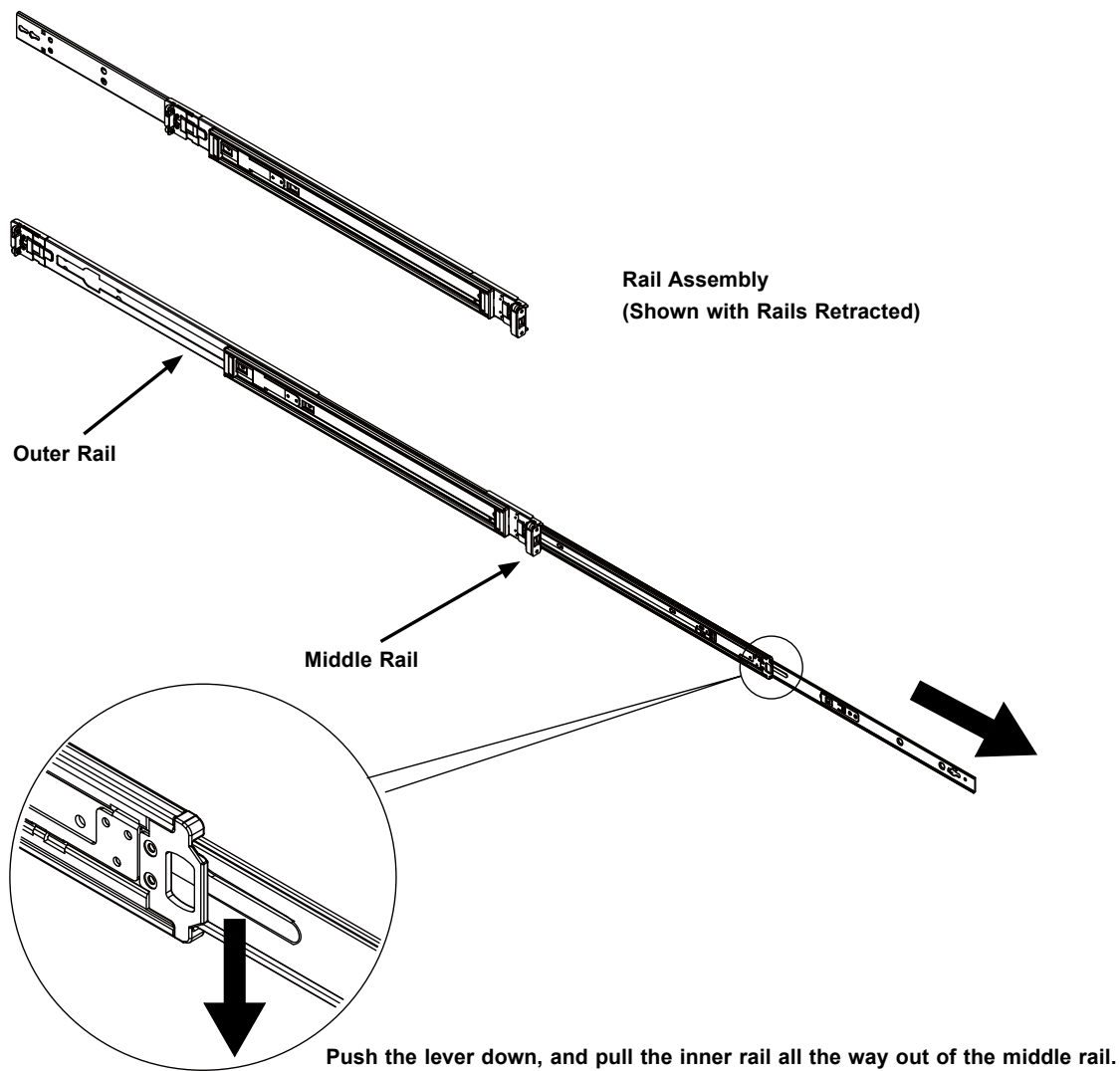
**Note:** Both front chassis rails and the rack rails have a locking tab, which serves two functions. First, it locks the chassis into place when installed and pushed fully into the rack (its normal operating position). In addition, these tabs lock the chassis in place when fully extended from the rack. This prevents the chassis from coming completely out of the rack when pulled out for servicing.

## Releasing the Inner Rail

Each inner rail has a locking latch. This latch prevents the chassis from coming completely out of the rack when the chassis is pulled out for servicing.

To mount the rail onto the chassis, first release the inner rail from the outer rails.

1. Pull the inner rail out of the outer rail until it is fully extended as illustrated below.
2. Press the locking tab down to release the inner rail.
3. Pull the inner rail all the way out.



**Figure 2-2. Extending and Releasing the Inner Rail**

## Installing the Inner Rails

Begin the rack mounting procedure by installing the inner rails to the chassis.

1. Identify the left and right inner rails. They are labeled.
2. Place the inner rail firmly against the side of the chassis, aligning the hooks on the side of the chassis with the holes in the inner rail.
3. Slide the inner rail forward toward the front of the chassis and under the hooks until the quick release bracket snaps into place, securing the rail to the chassis.
4. Optionally, you can further secure the inner rail to the chassis with a screw.

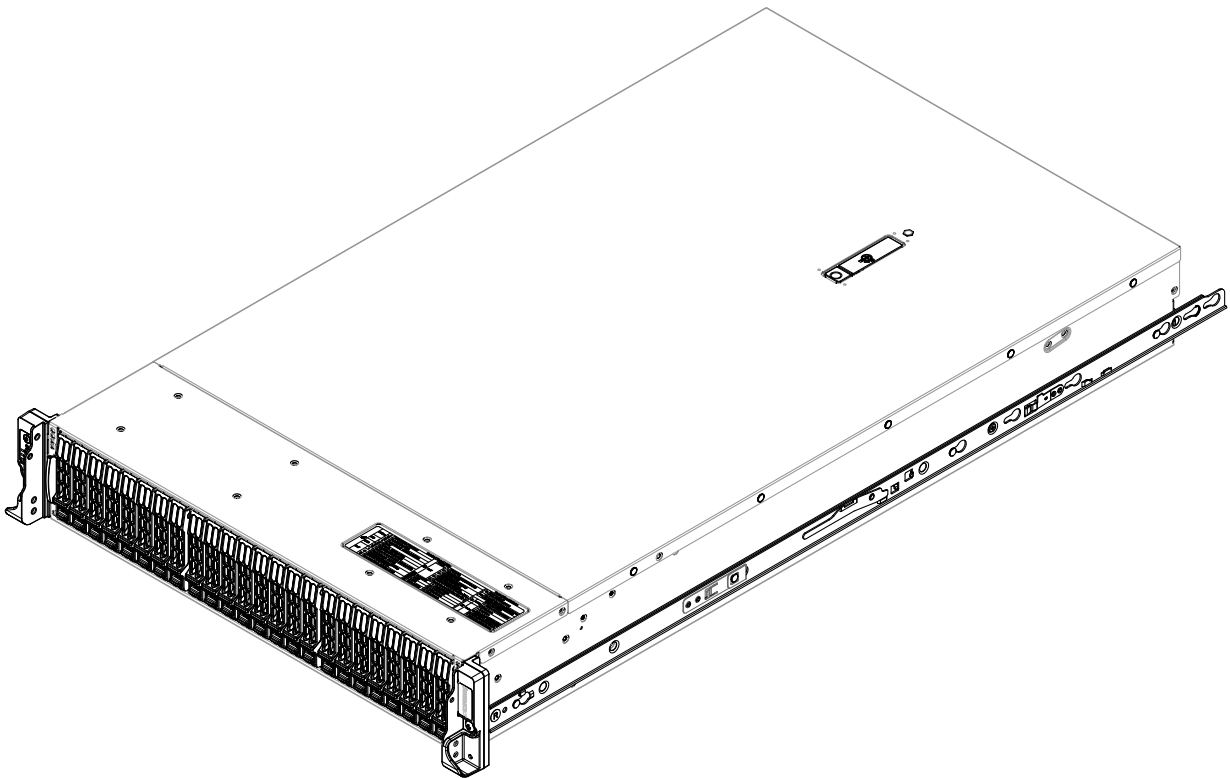


Figure 2-3. Installing the Rails

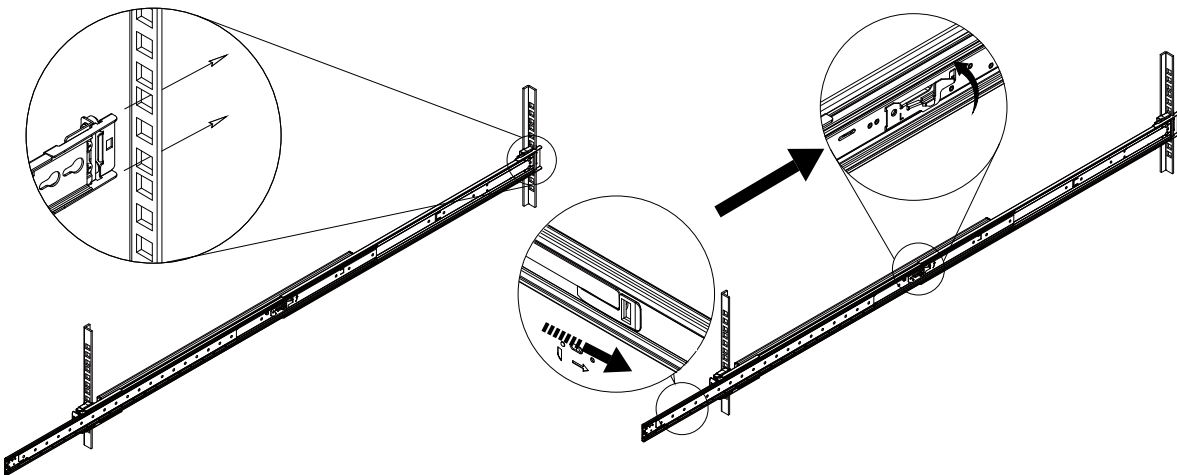


**Warning:** Do not pick up the chassis with the front handles. They are designed to pull the system from a rack only.

## Installing the Outer Rails onto the Rack

### *Installing the Outer Rails*

1. Press upward on the locking tab at the rear end of the middle rail.
2. Push the middle rail back into the outer rail.
3. Hang the hooks on the front of the outer rail onto the square holes on the front of the rack. If desired, use screws to secure the outer rails to the rack.
4. Pull out the rear of the outer rail, adjusting the length until it just fits within the posts of the rack.
5. Hang the hooks of the rear section of the outer rail onto the square holes on the rear of the rack. Take care that the proper holes are used so the rails are level. If desired, use screws to secure the rear of the outer rail to the rear of the rack.
6. Repeat for the other outer rail.



**Figure 2-4. Extending and Mounting the Outer Rails**

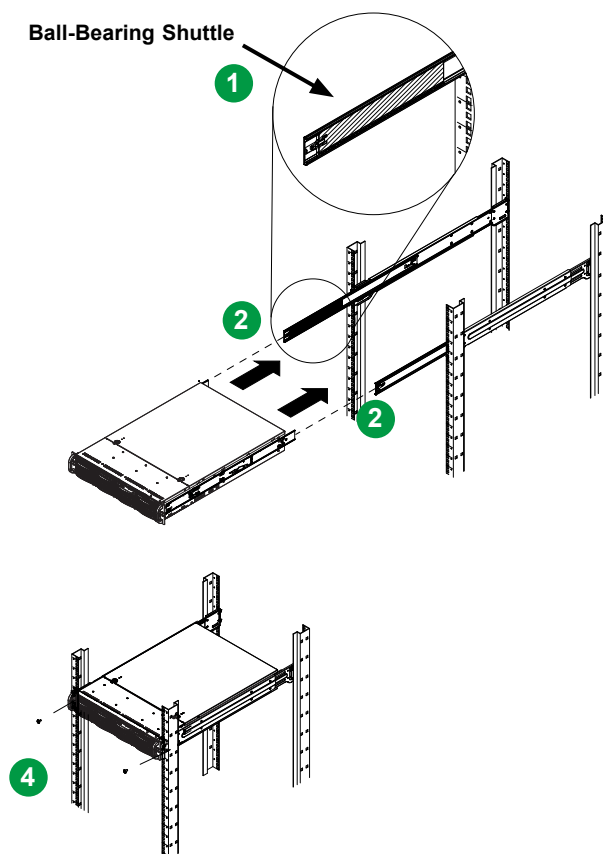
## 2.6 Installing the Chassis into a Rack

Once rails are attached to the chassis and the rack, you can install the server.

**Warning:** Mounting the system into the rack requires at least two people to support the chassis during installation. Please follow safety recommendations printed on the rails.

### *Installing the Chassis into a Rack*

1. Extend the outer rails as illustrated.
2. Align the inner rails of the chassis with the outer rails on the rack.
3. Slide the inner rails into the outer rails, keeping the pressure even on both sides. When the chassis has been pushed completely into the rack, it should click into the locked position.
4. Optional screws may be used to hold the front of the chassis to the rack.



**Figure 2-5. Installing the Server into the Rack**

**Note:** Keep the ball bearing shuttle locked at the front of the middle rail during installation.

**Note:** Figure is for illustrative purposes only. Always install servers to the bottom of a rack first.

## Removing the Chassis from the Rack

**Caution!** It is dangerous for a single person to off-load the heavy chassis from the rack without assistance. Be sure to have sufficient assistance supporting the chassis when removing it from the rack. Use a lift.

1. Pull the chassis forward out the front of the rack until it stops.
2. Press the release latches on each of the inner rails downward simultaneously and continue to pull the chassis forward and out of the rack.

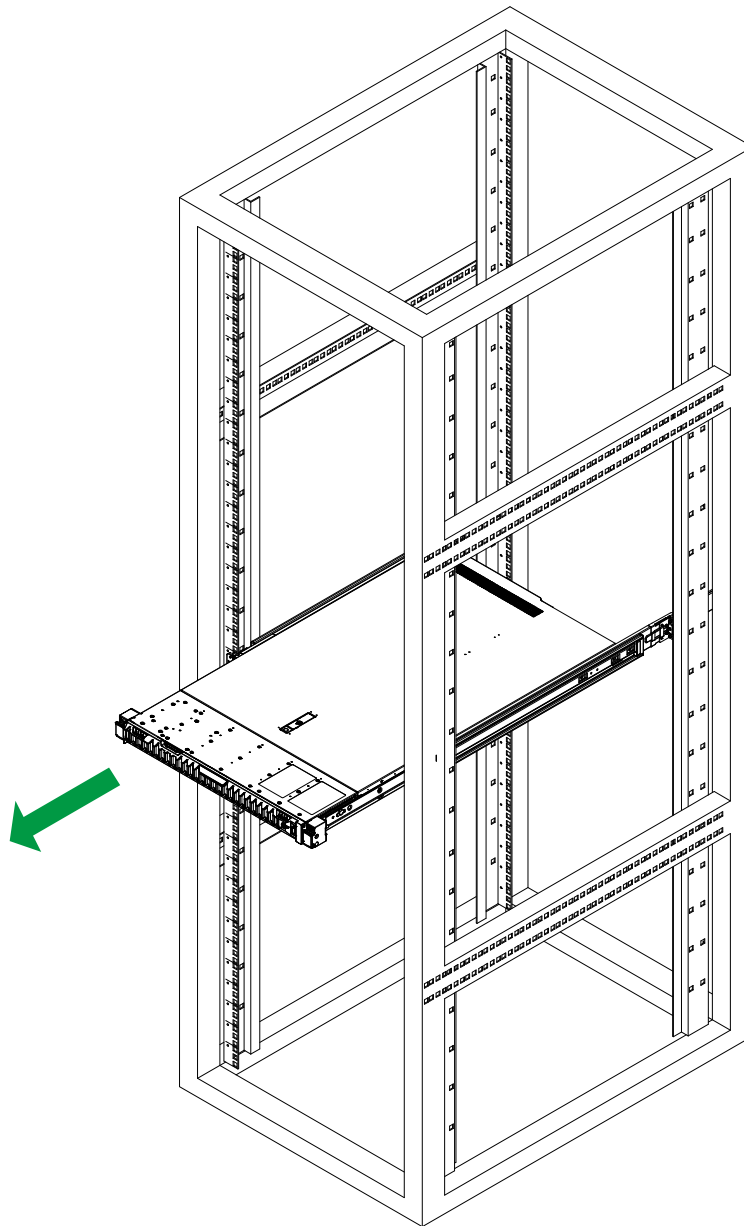


Figure 2-6. Removing the Chassis From the Rack



## Chapter 3

# Maintenance and Component Installation

This chapter provides instructions on installing and replacing main system components. To prevent compatibility issues, only use components that match the specifications and/or part numbers given.

Installation or replacement of most components requires that power first be removed from the system. Please follow the procedures given in each section.

### 3.1 Removing Power

Use the following procedure to ensure that power has been removed from the system. This step is necessary when removing or installing non-hot-swap components or when replacing a non-redundant power supply.

1. Use the operating system to power down the system.
2. After the system has completely shut-down, disconnect the AC power cord(s) from the power strip or outlet. (If your system has more than one power supply, remove the AC power cords from all power supply modules.)
3. Disconnect the power cord(s) from the power supply module(s).

## 3.2 Accessing the System

The CSE-HS219-R1K24P and CSE-HS219-R1K63P chassis feature a removable top cover, which allows easy access to the inside of the chassis.

### *Removing the Top Cover*

1. Press the release button and slide the cover toward the rear.
2. Lift the top cover-up.

Check that all ventilation openings on the top cover and the top of the chassis are clear and unobstructed.

**Caution:** Except for short periods of time, do not operate the server without the cover in place. The chassis cover must be in place to allow for proper airflow and to prevent overheating.

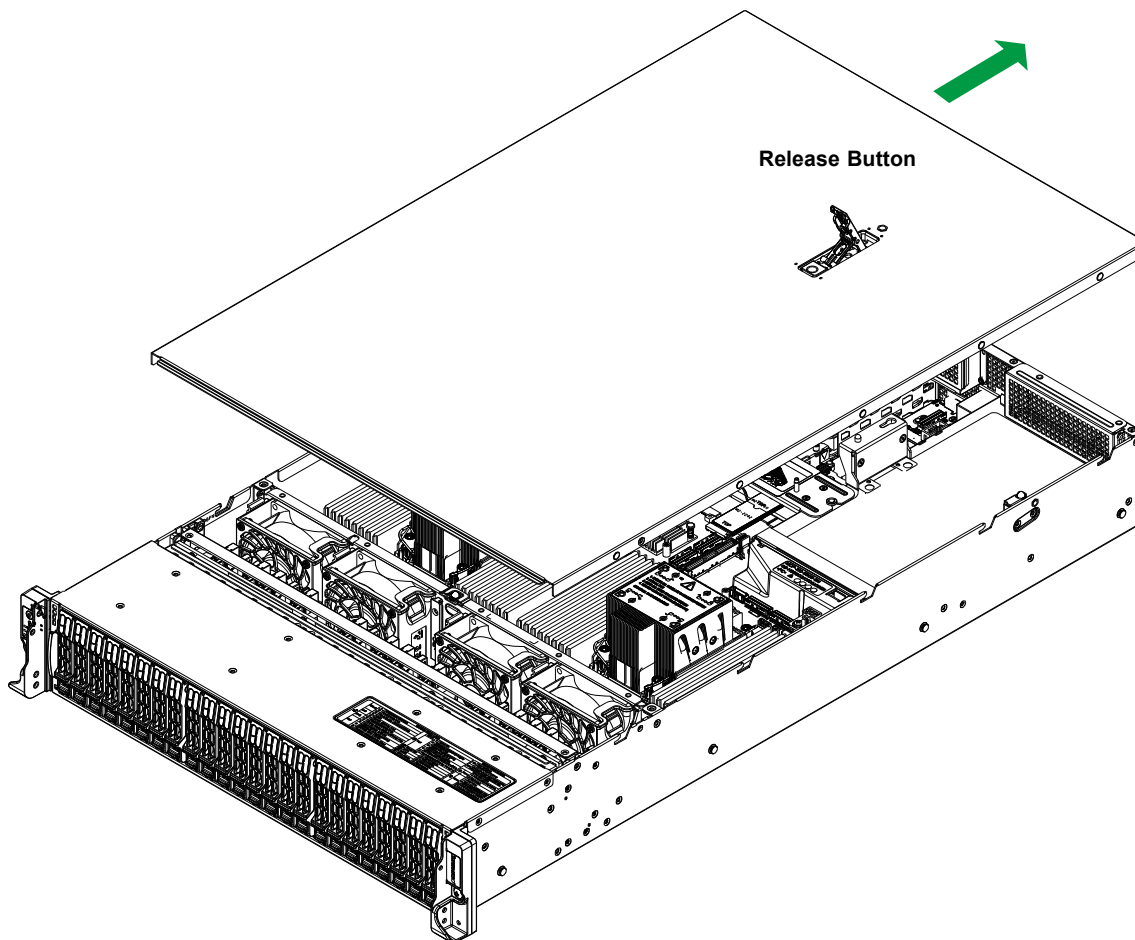


Figure 3-1. Removing the Chassis Cover

## 3.3 Static-Sensitive Devices

Electrostatic Discharge (ESD) can damage electronic components. To avoid damaging your motherboard, it is important to handle it very carefully. The following measures are generally sufficient to protect the system PCBs from ESD.

### Precautions

- Use a grounded wrist strap designed to prevent static discharge.
- Touch a grounded metal object before removing any PCB (printed circuit board) from its antistatic bag.
- Handle PCBs by their edges only; do not touch its components, peripheral chips, memory modules, or gold contacts.
- When handling chips or modules, avoid touching their pins.
- Put the PCBs back into their antistatic bags when not in use.
- For grounding purposes, make sure that your computer chassis provides excellent conductivity between the power supply, the case, the mounting fasteners and the motherboard.
- Use only the correct type of onboard CMOS battery. Do not install the onboard battery upside down to avoid a possible explosion

### Unpacking

The motherboard is shipped in antistatic packaging to avoid static damage. When unpacking the motherboard, make sure that the person handling it is static protected.

## 3.4 Processor and Heatsink Installation

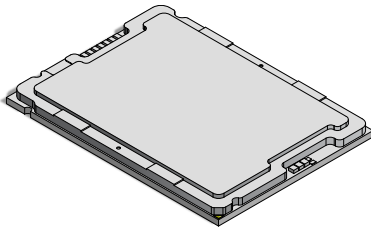
The processor (CPU) and processor carrier should be assembled together first to form the processor carrier assembly. This assembly will be then attached to the heatsink to form the processor heatsink module (PHM) before being installed into the CPU socket. Before installation, be sure to perform the following steps below:

- Please carefully follow the instructions given on the previous page to avoid ESD-related damages.
- Unplug the AC power cords from all power supplies after shutting down the system.
- Check that the plastic protective cover is on the CPU socket, and none of the socket pins are bent. If they are, contact your retailer.
- When handling the processor, avoid touching or placing direct pressure on the LGA lands (gold contacts). Improper installation or socket misalignment can cause serious damage to the processor or CPU socket, which may require manufacturer repairs.
- When installing the processor and heatsink, ensure a torque driver set to the correct force is used for each screw.
- Thermal grease is pre-applied on a new heatsink. No additional thermal grease is needed.
- Refer to the Supermicro website for updates on processor and memory support.
- All graphics in this manual are for illustrations only. Your components may look different.

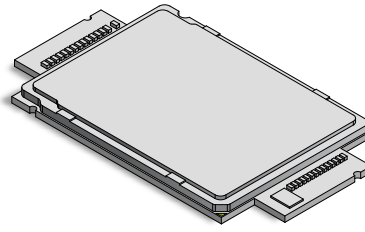
**Note:** The installation process is the same for both 4th and 5th Gen Intel Xeon Scalable processors. Please use the 4th Gen Intel Xeon Scalable processor installation process as a reference.

## The 4th and 5th Gen Intel Xeon Scalable Processor

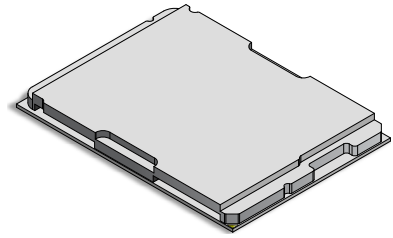
Processor Top View



SP XCC Series



Max Series (HBM)

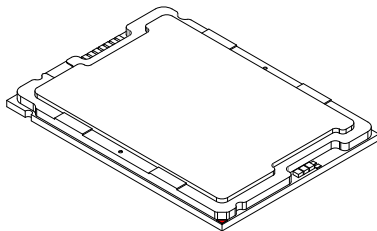


SP MCC Series

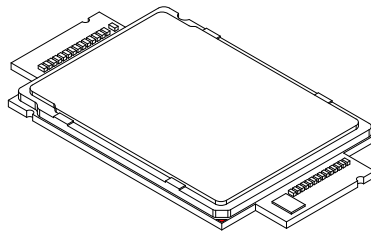
### 1. The 4<sup>th</sup> and 5<sup>th</sup> Gen. Intel Xeon Scalable Processor

Processor Top View

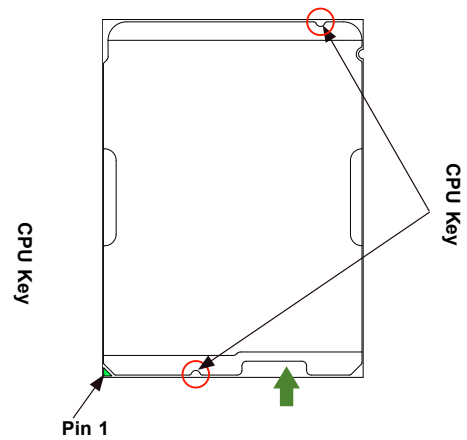
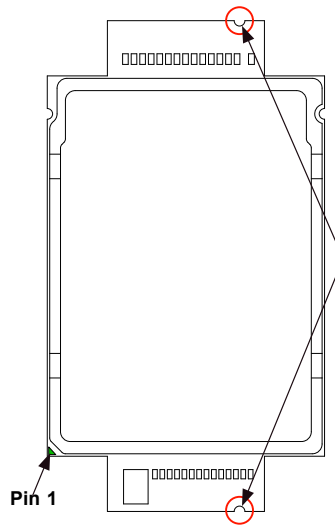
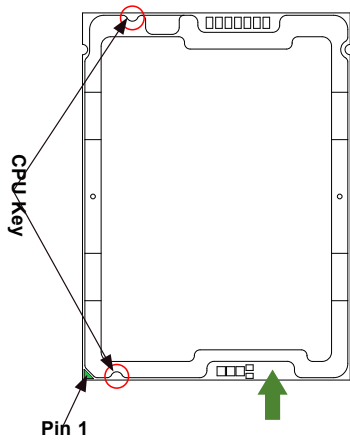
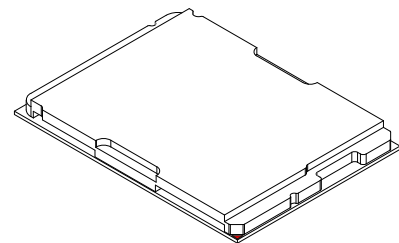
SP XCC Series



Max Series (HBM)



SP MCC Series



➡ = Cutout    ▲ = Pin 1    ○ = CPU Key

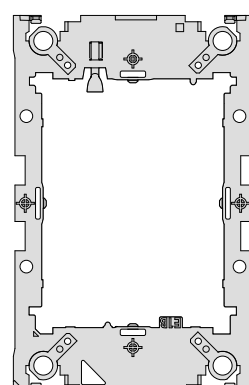
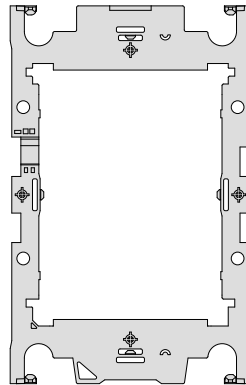
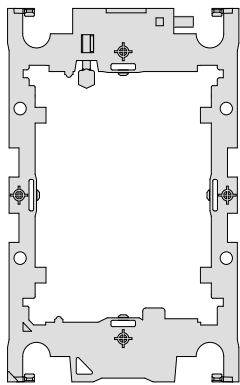
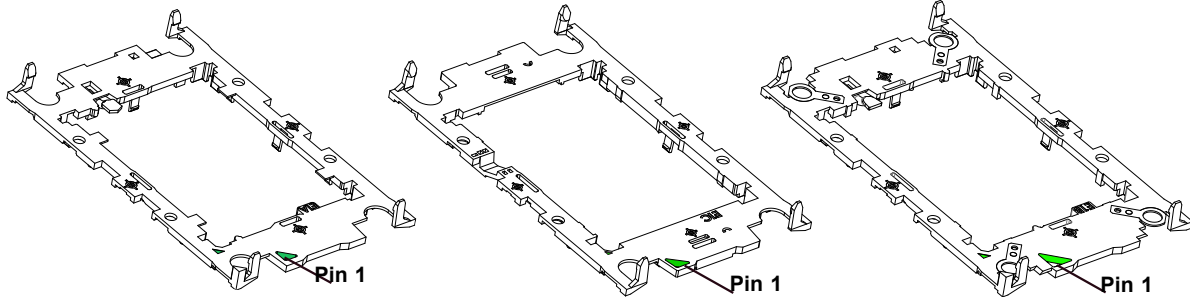
Processor Bottom View

2. The CPU Carrier

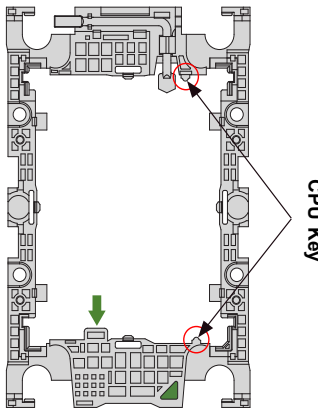
**SP XCC Series**

**Max Series (HBM)**

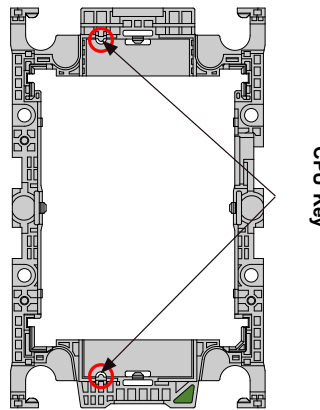
**SP MCC Series**



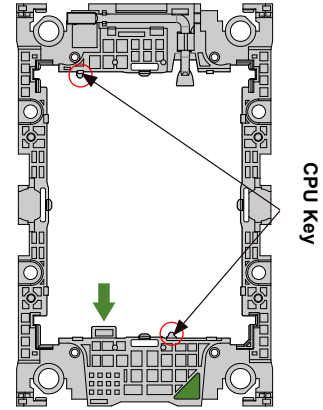
**Carrier Top View**



**SP XCC Series**



**Max Series (HBM)**



**SP MCC Series**



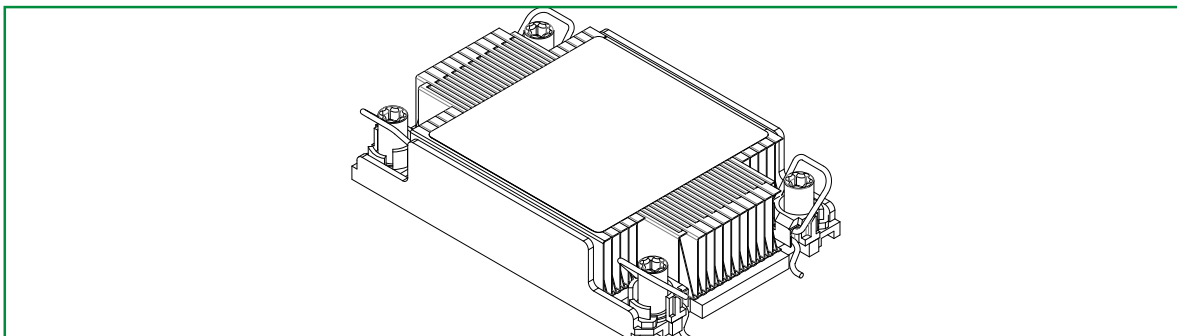
**Carrier Bottom View**

**Note 1:** The 4<sup>th</sup> and 5<sup>th</sup> Gen Intel® Xeon® Scalable Processor comes with the following SKUs: SP XCC, Max Series (HBM), and SP MCC SKUs. Each CPU SKU supports a specific carrier. The SP XCC Series CPU supports Carrier E1A; the Max Series (HBM) CPU supports Carrier E1C, and the SP MCC Series, Carrier E1B.

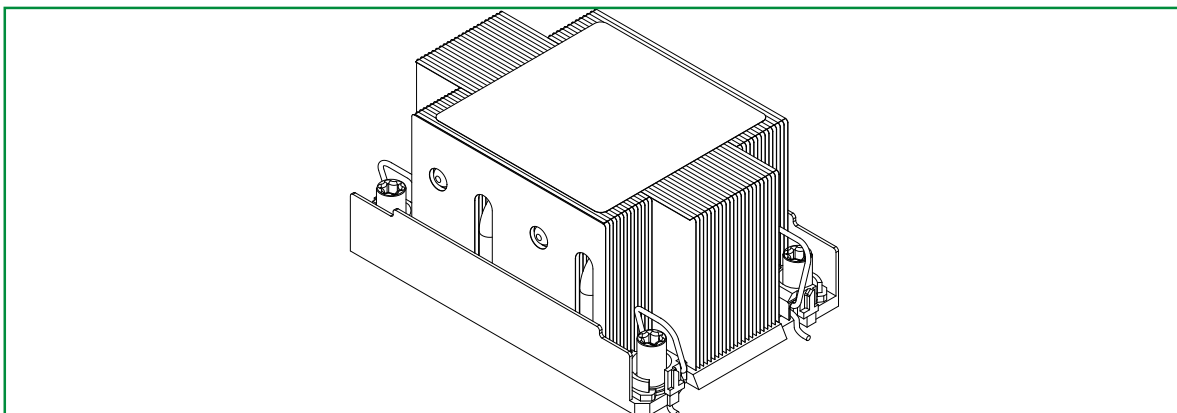
**Note 2:** Please be sure to use processors of the same SKU on this motherboard.

### 3. Heatsink

#### 1U Heatsink



#### 2U Heatsink



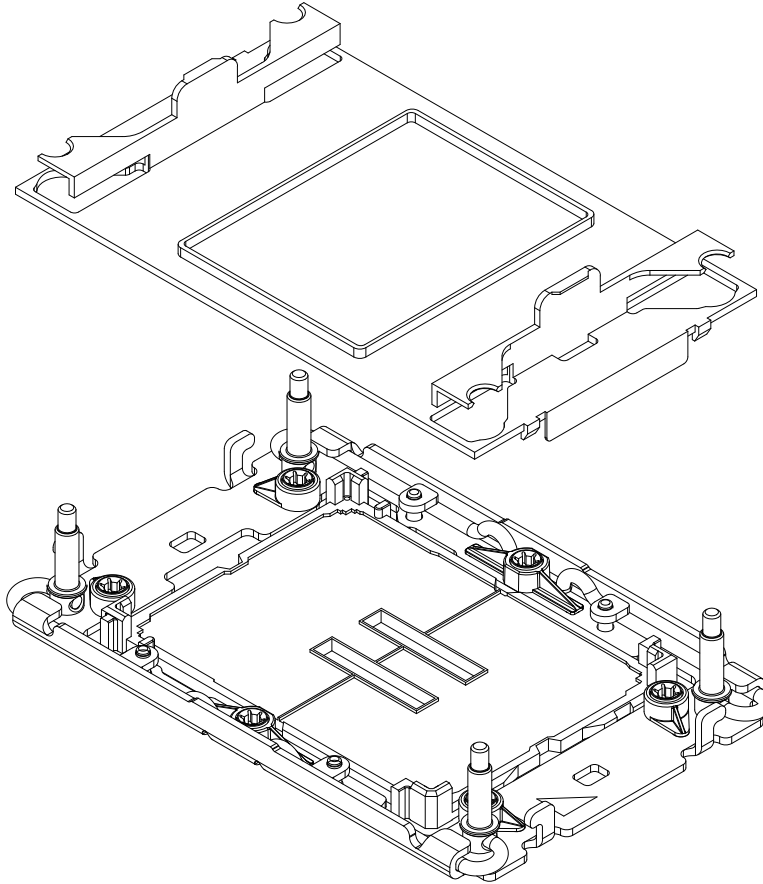
**Note 1:** Exercise extreme care when handling the heatsink. Pay attention to the edges of heatsink fins, which can be sharp! To avoid damaging the heatsink, please do not apply excessive force on the fins.

**Note 2:** This installation section provides instructions on how to install 1U heatsink/2U heatsink, which are supported by your system.

## Overview of the CPU Socket

The CPU socket is protected by a plastic protective cover.

**Plastic Protective Cover**



**CPU Socket**



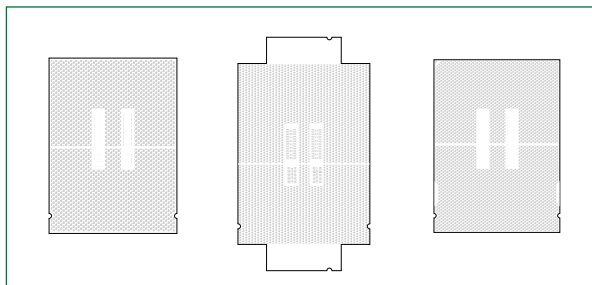
## Overview of the Processor Carrier Assembly

The processor carrier assembly contains a 4<sup>th</sup> and 5<sup>th</sup> Gen Intel Xeon Scalable processor and a processor carrier. Carefully follow the instructions given in the installation section to place a processor into the carrier to create a processor carrier.

The processor carrier assembly includes a processor and a carrier as shown below:

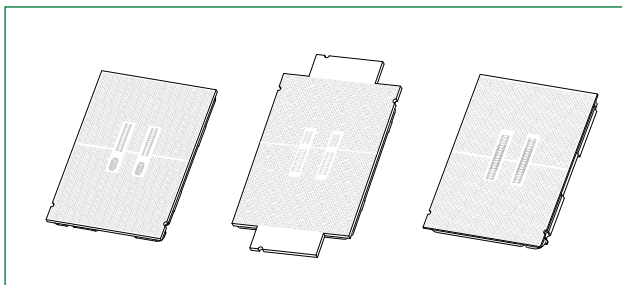
1. The 4<sup>th</sup> and 5<sup>th</sup> Gen Intel Xeon Scalable Processor: SP XCC, Max Series (HBM), and SP MCC.

**Processor (2D)**



**SP XCC    Max Series (HBM)    SP MCC**

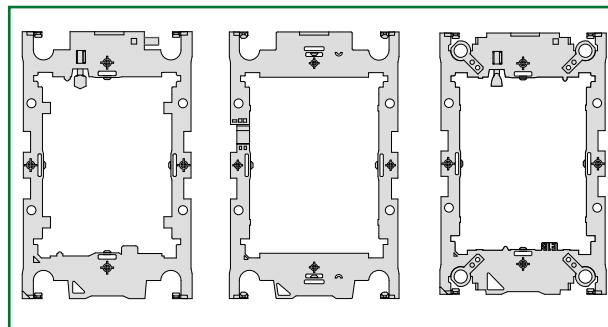
**Processor (3D)**



**SP XCC    Max Series (HBM)    SP MCC**

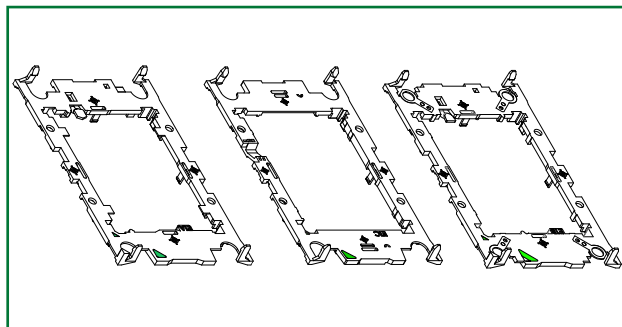
2. CPU Carrier (Top View) for: SP XCC, Max Series (HBM), and SP MCC.

**CPU Carrier (2D)**



**Carrier E1A    Carrier E1C    Carrier E1B**  
for XCC                      for Max Series (HBM)                      for MCC

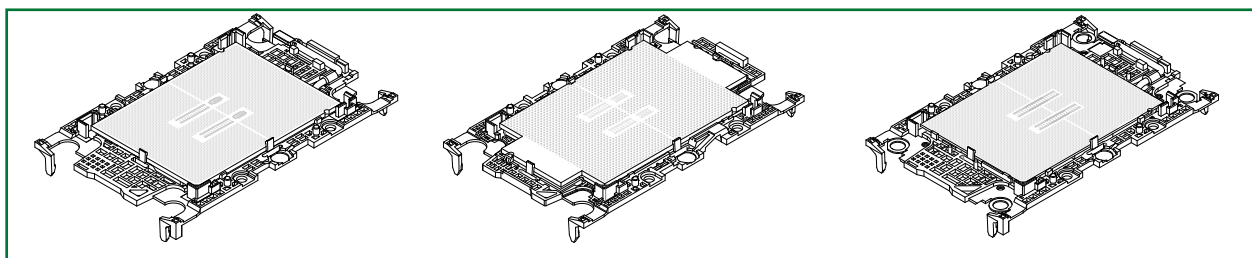
**CPU Carrier (3D)**



**Carrier E1A    Carrier E1C    Carrier E1B**



3. CPU Carrier Assembly



**SP XCC & E1A**

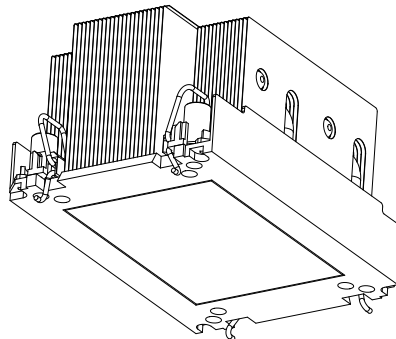
**Max Series (HBM) & E1C**

**SP MCC & E1B**

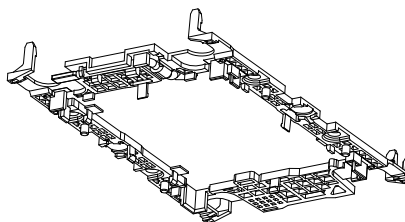
## Overview of the Processor Heatsink Module (PHM)

The Processor Heatsink Module (PHM) contains a heatsink, a processor carrier, and a 4<sup>th</sup> and 5<sup>th</sup> Gen Intel Xeon Scalable processor.

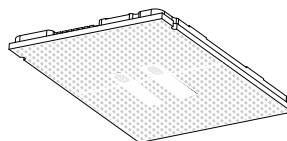
1. 2U Heatsink (Bottom View)



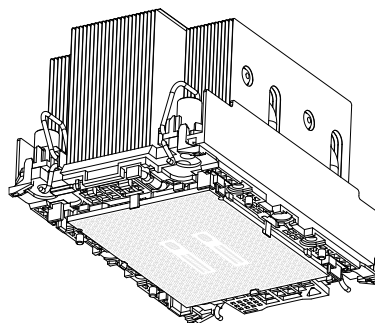
2. Processor Carrier E1A



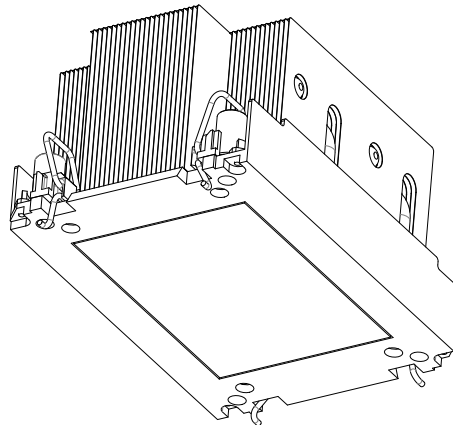
3. The 4<sup>th</sup> and 5<sup>th</sup> Gen Intel Xeon Scalable Processor (SP XCC Series Component Side)



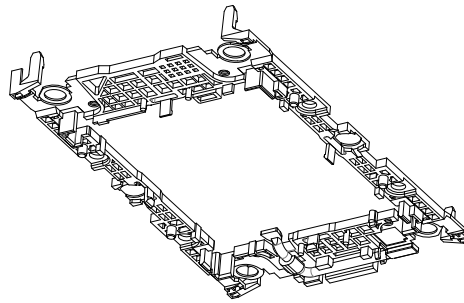
4. Processor Heatsink Module (PHM) (Bottom View Shown Below)



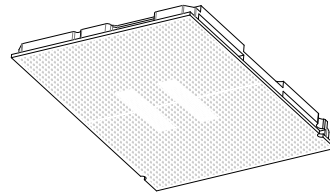
1. 2U Heatsink (Bottom View Shown Below for SP MCC Illustration)



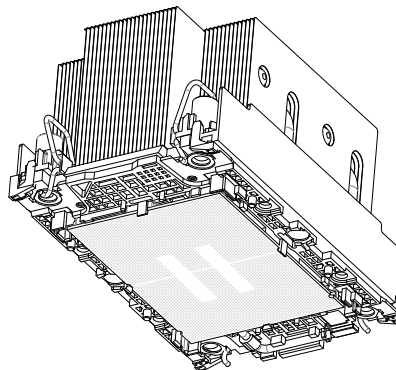
2. CPU Carrier E1B



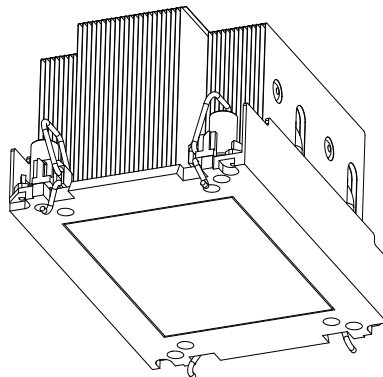
3. The 4<sup>th</sup> and 5<sup>th</sup> Gen Intel Xeon Scalable Processor (SP MCC Series Component Side)



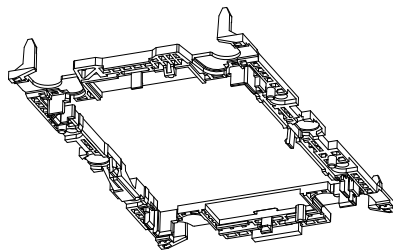
4. Processor Heatsink Module (PHM) (Bottom View Shown Below)



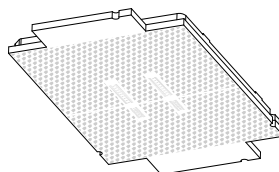
1. 2U Heatsink (Bottom View Shown Below for Max Series (HBM Illustration))



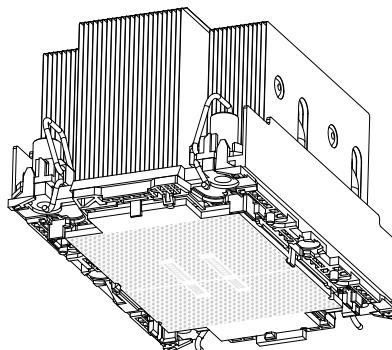
2. Processor Carrier E1C



3. The 4<sup>th</sup> and 5<sup>th</sup> Gen Intel Xeon Scalable Processor (Max Series ((HBM)) Component Side)



4. Processor Heatsink Module (PHM) (Bottom View Shown Below)



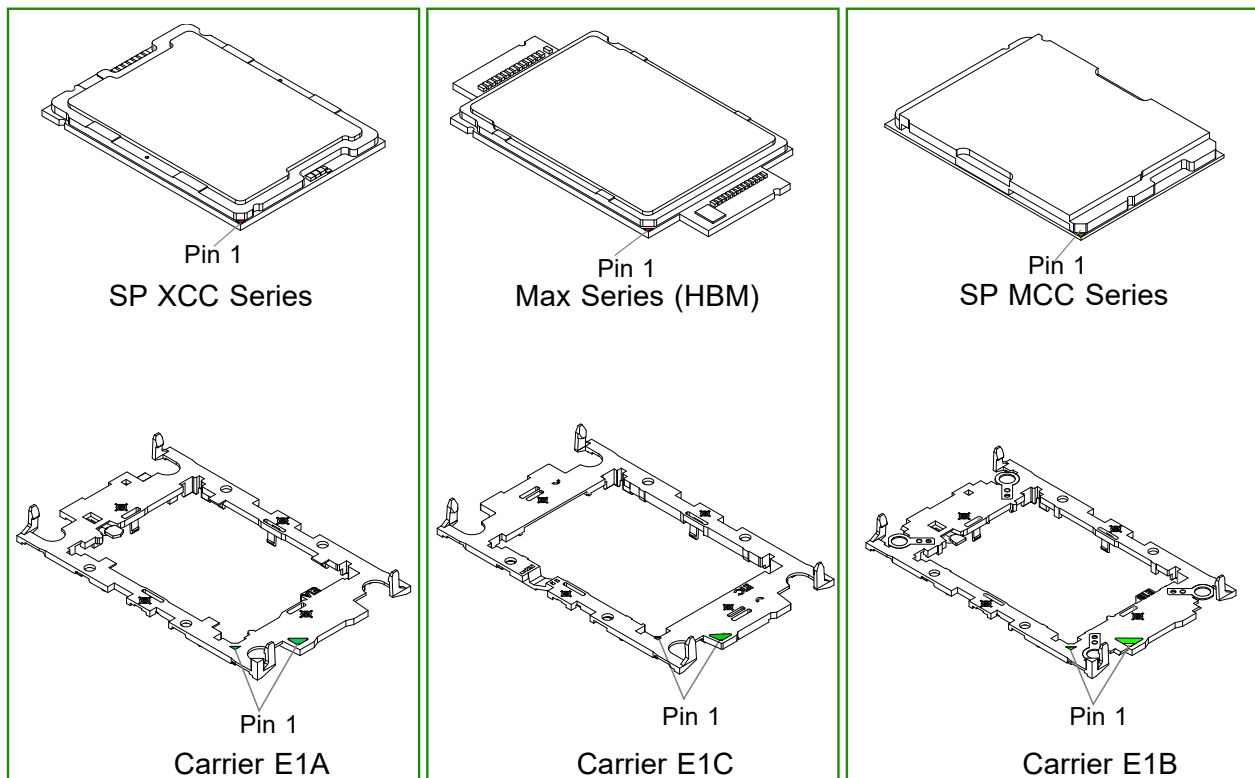
## Creating the Processor Carrier Assembly

The processor carrier assembly contains a 4<sup>th</sup> and 5<sup>th</sup> Gen Intel Xeon Scalable processor and a processor carrier.

To create the processor carrier assembly, please follow the steps below:

**Note:** Before installation, be sure to follow the instructions given on pages 1 and 2 of this chapter to properly prepare for installation.

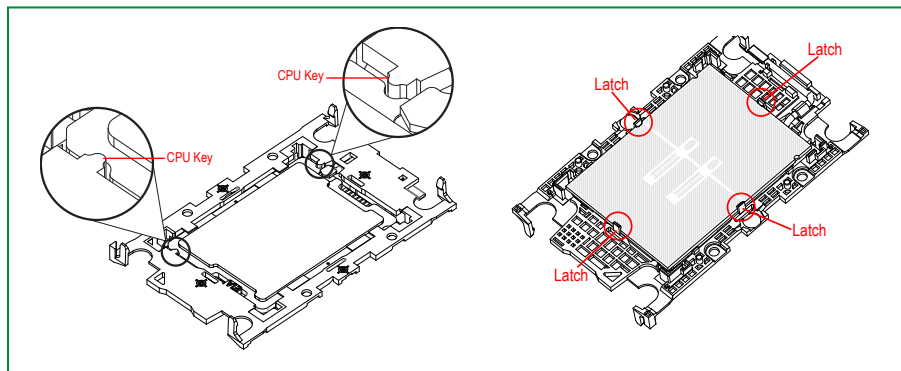
1. Hold the processor with the component side (including the gold contacts) facing down. Locate the small, gold triangle at the corner of the processor and the corresponding hollowed triangle on the processor carrier as shown in the graphics below. Please note that the triangle indicates the Pin 1 location.



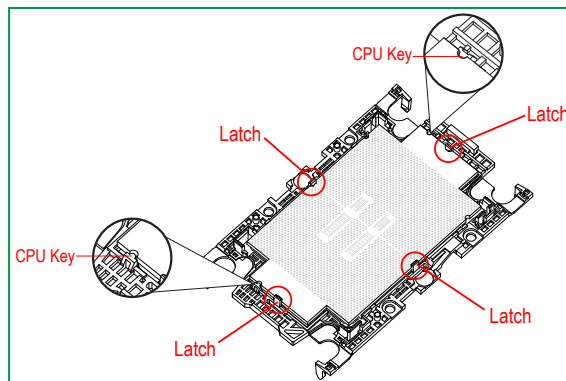
**Processor with matching carriers**

- Turn over the processor carrier and locate Pin 1 on the CPU and Pin 1 on the carrier. Then, turn the processor over with component side (including the gold contacts) facing up and locate CPU keys on the processor. Finally, locate the CPU keys and four latches on the carrier as shown below.

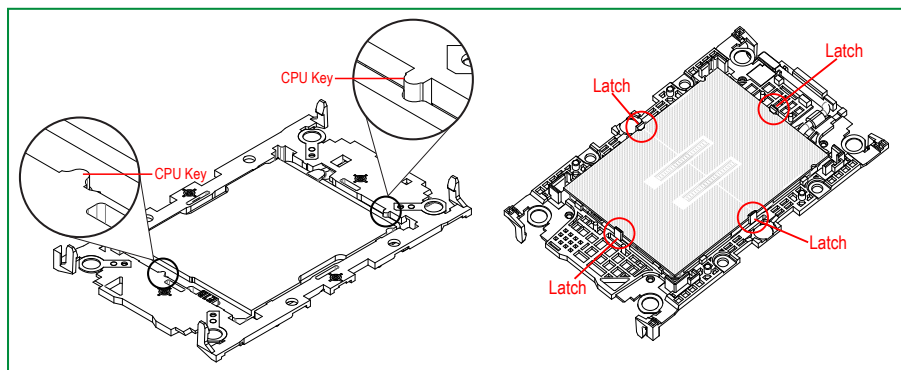
### SP XCC Series



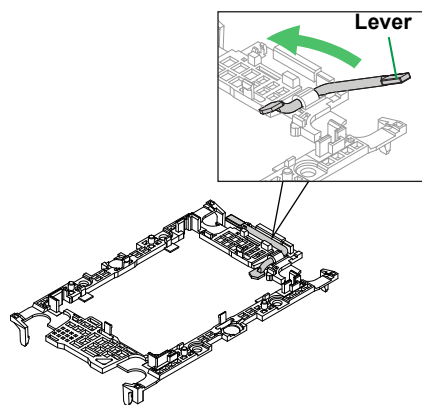
### Max Series (HBM)



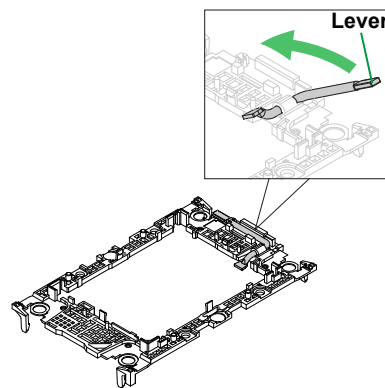
### SP MCC Series



3. Locate the lever on the CPU socket and press it down as shown below.

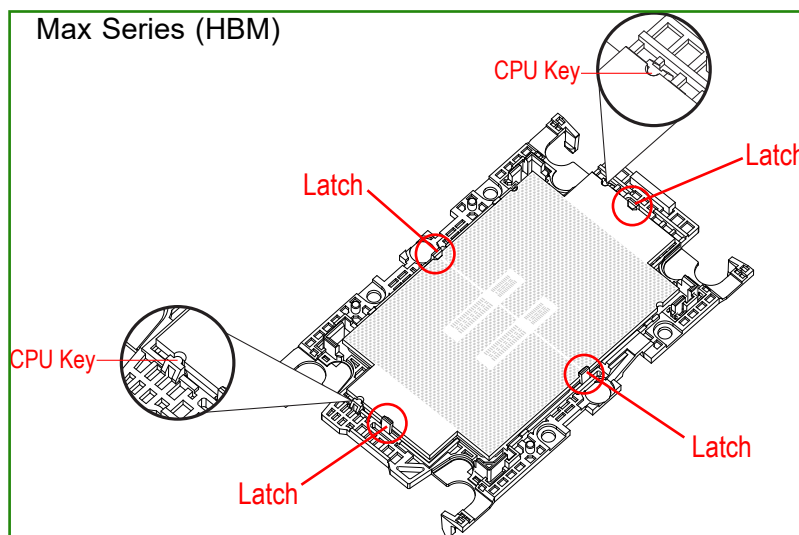
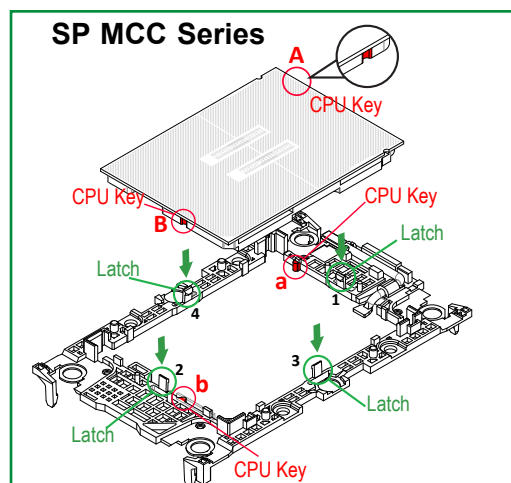
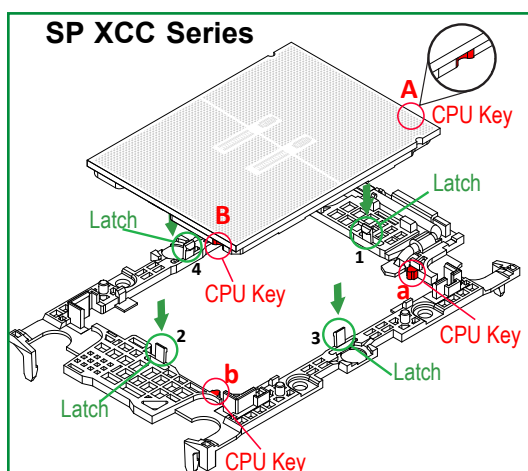


Carrier E1A

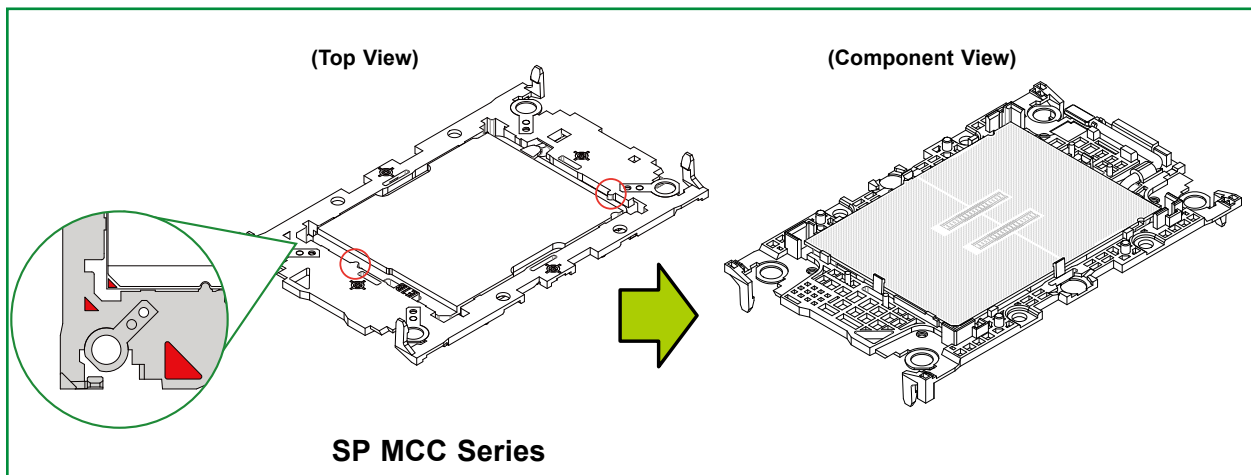
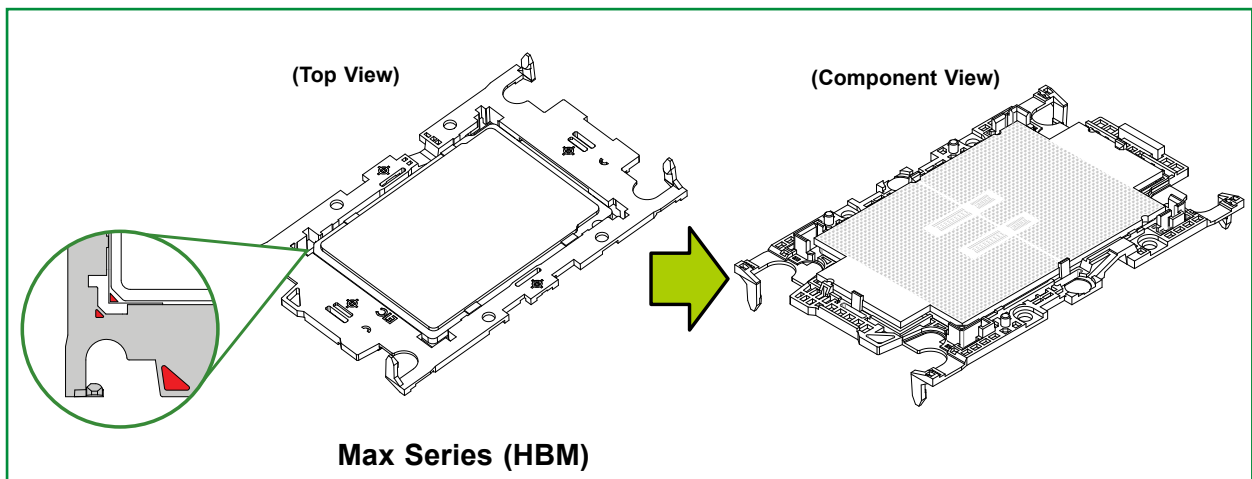
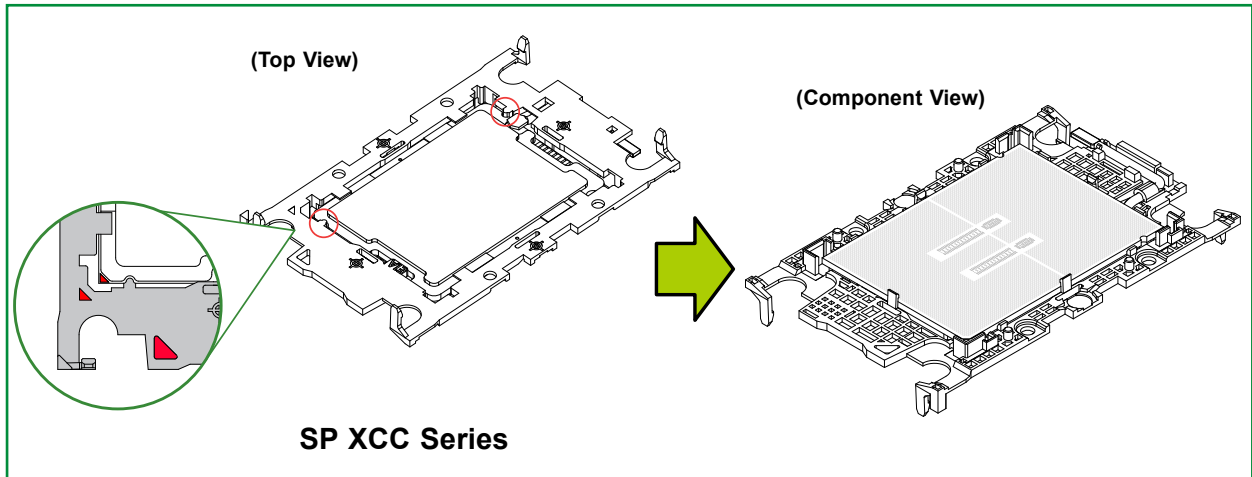


Carrier E1B

4. Using Pin 1 as a guide, carefully align the CPU keys (A and B) on the processor against the CPU keys on the carrier (a and b) as shown in the drawing below.
5. Once they are properly aligned, carefully insert the CPU into the carrier, making sure that the CPU is properly secured by latches 1, 2, 3, and 4.



6. After the processor is placed inside the carrier, examine the four sides of the processor, making sure that the processor is properly seated on the carrier.



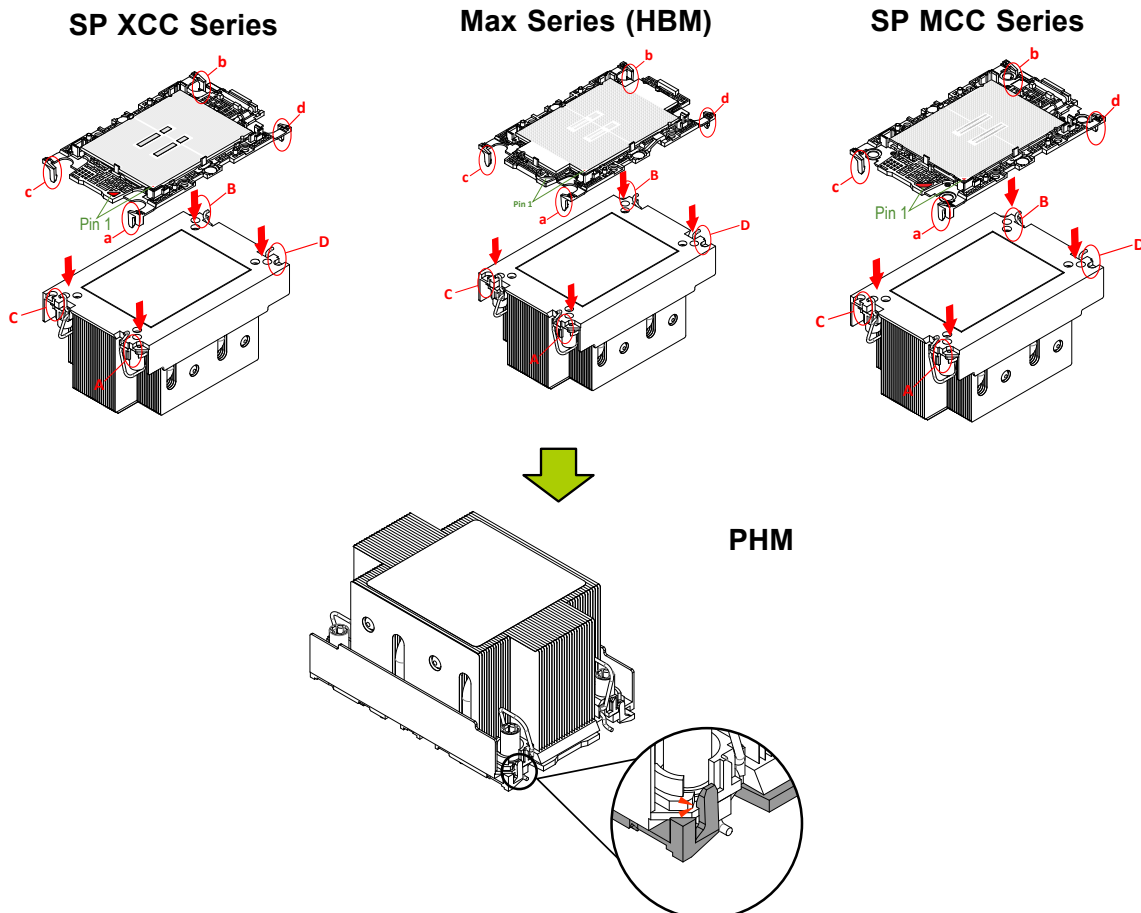


## Creating the Processor Heatsink Module (PHM)

After creating the processor carrier assembly, please follow the instructions below to mount the processor carrier into the heatsink to form the PHM.

**Note:** If this is a new heatsink, the thermal grease has been pre-applied on the underside. Otherwise, apply the proper amount of thermal grease.

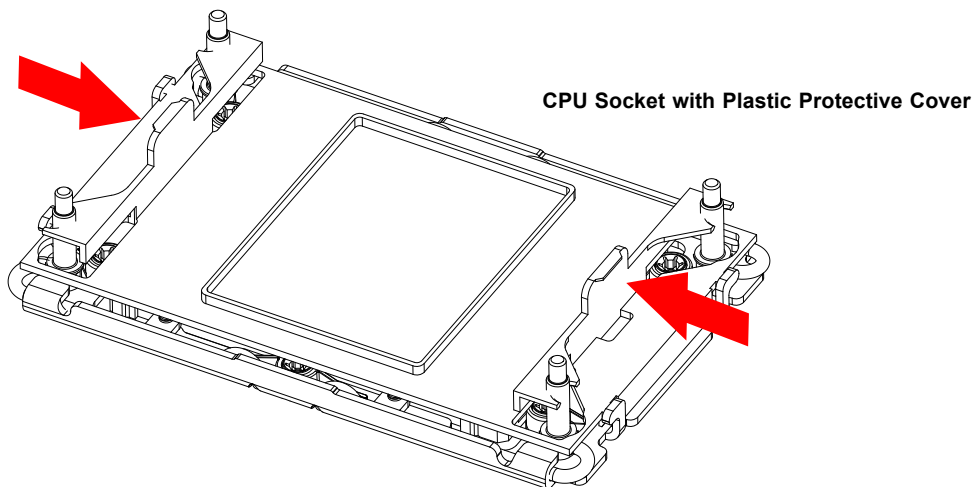
1. Turn the heatsink over with the thermal grease, which is on the reverse side of the heatsink, facing up. Pay attention to the two triangle cutouts (A, B) located at the diagonal corners of the heatsink as shown in the drawing below.
2. Hold the processor carrier component side facing up, and locate the triangle on the CPU and the triangle on the carrier. (Triangle indicates Pin 1.)
3. Using Pin 1 as a guide, turn the processor carrier assembly over with the gold contacts facing up. Locate Pin 1 (A) on the processor and Pin 1 (a) on the processor carrier assembly.
4. Align the corner marked a on the processor carrier assembly against the triangle cutout A on the heatsink, and align the corners marked b, c, and d on the processor assembly against the corners marked B, C, and D on the heatsink.
5. Once they are properly aligned, place the corners marked a, b, c, and d on the processor carrier assembly into the corners of the heatsink marked A, B, C, and D making sure that all plastic clips are properly attached to the heatsink.



## Preparing the CPU Socket for Installation

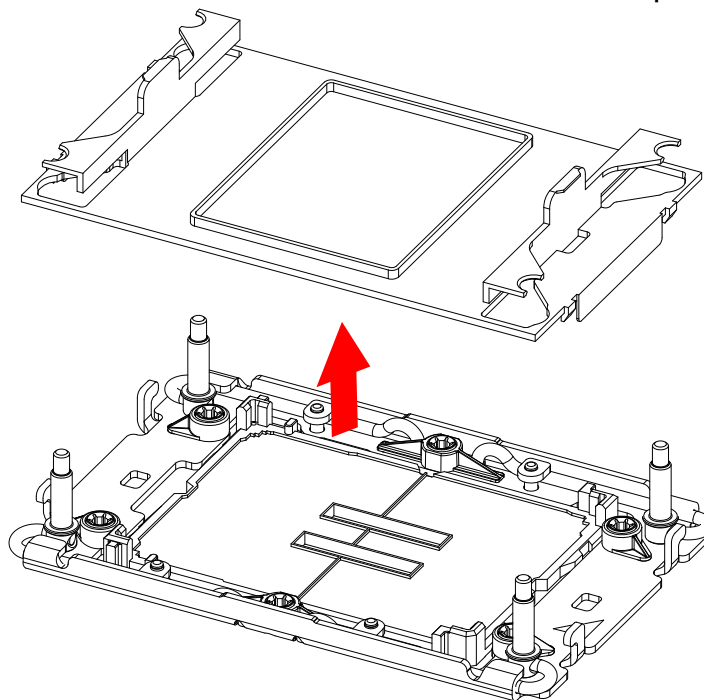
This motherboard comes with a plastic protective cover installed on the CPU socket. Remove it from the socket by following the instructions below:

1. Press the tabs inward.



2. Pull up the protective cover from the socket.

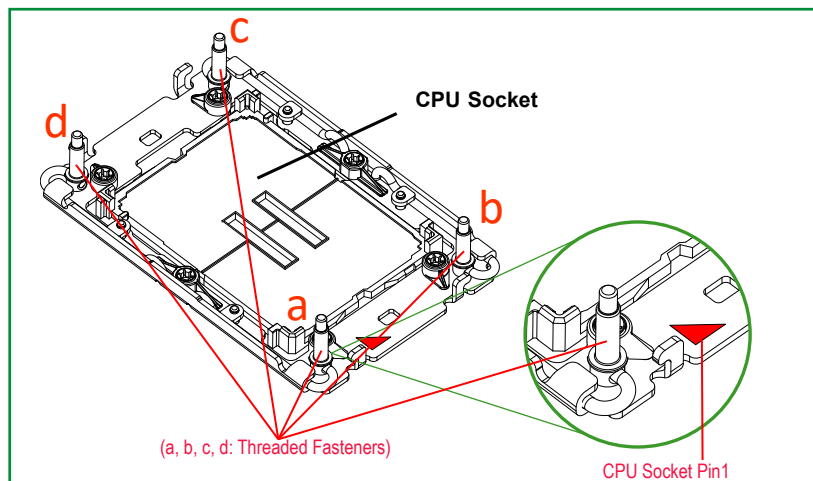
**Remove the plastic protective cover from the CPU socket.  
Do not touch or bend the socket pins.**



## Preparing to Install the PHM into the CPU Socket

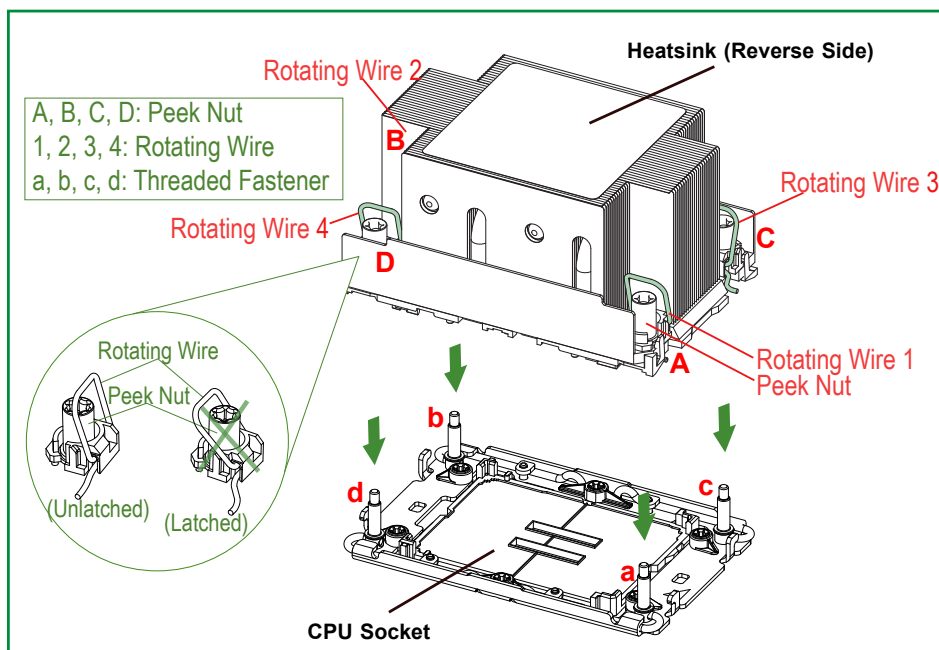
After assembling the Processor Heatsink Module, you are ready to install it into the CPU socket. To ensure proper installation, please follow the procedures below:

1. Locate four threaded fasteners (a, b, c, d) on the CPU socket.

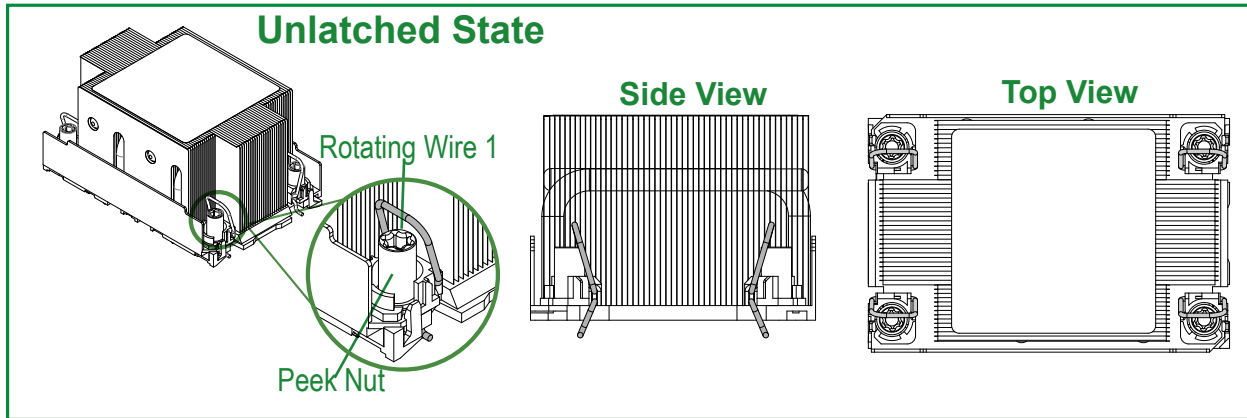


Mount the Processor Heatsink Module onto the CPU socket (on the motherboard)

2. Locate four PEEK nuts (A, B, C, D) and four rotating wires (1, 2, 3, 4) on the heatsink as shown in the graphics below.

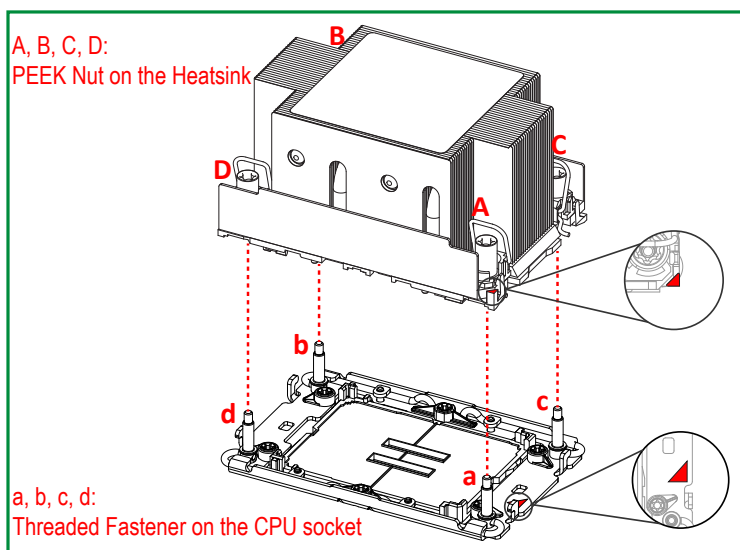


3. Check the rotating wires (1, 2, 3, 4) to make sure that they are at unlatched positions as shown in the drawing below before installing the PHM into the CPU socket.

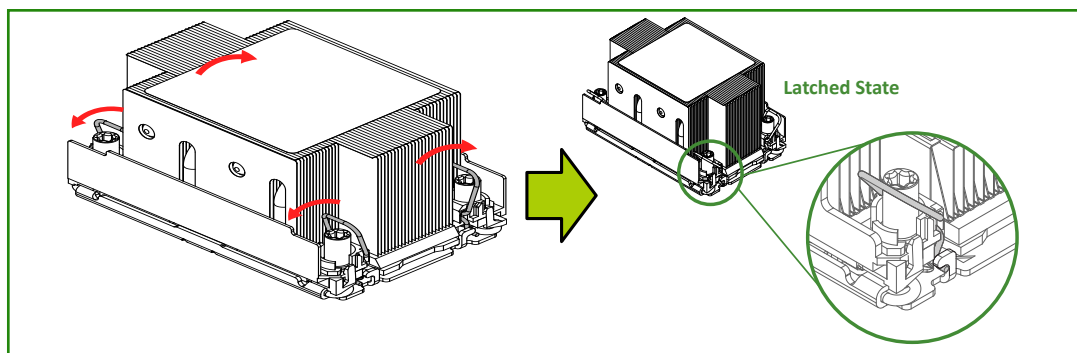


## Installing the PHM into the CPU Socket

1. Align PEEK nut A, which is next to the triangle (Pin 1) on the heatsink, against threaded fastener a on the CPU socket. Then align PEEK nuts B, C, and D on the heatsink against threaded fasteners b, c, and d on the CPU socket, making sure that all PEEK nuts on the heatsink are properly aligned with the correspondent threaded fasteners on the CPU socket.
2. Once they are aligned, gently place the heatsink on top the CPU socket, making sure that each PEEK nut is properly attached to its corresponding threaded fastener.



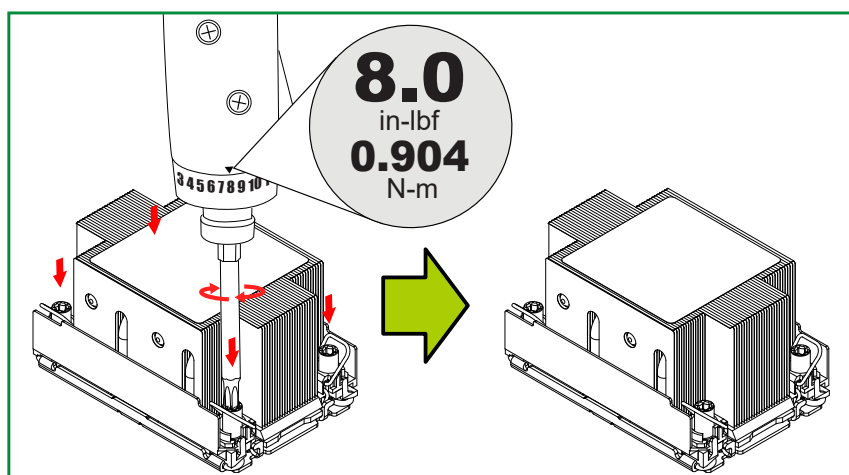
3. Press all four rotating wires outwards and make sure that the heatsink is securely latched onto the CPU socket.



4. With a T30 bit torque driver set to a force of 8.0 in-lbf (0.904 N-m), gradually tighten all PEEK nuts in the sequence of A, B, C, and D with even pressure. To avoid damaging the processor or socket, do not use excessive force when tightening the PEEK nuts. (For best durability, 8.0 in-lbf torque is recommended.)

**Important:** Do not use a force greater than 8.0 in-lbf (0.904 N-m). Exceeding this force may over-torque the screw, causing damage to the processor, heatsink, and nuts.

5. Examine all corners of the heatsink to ensure that the PHM is firmly attached to the CPU socket.

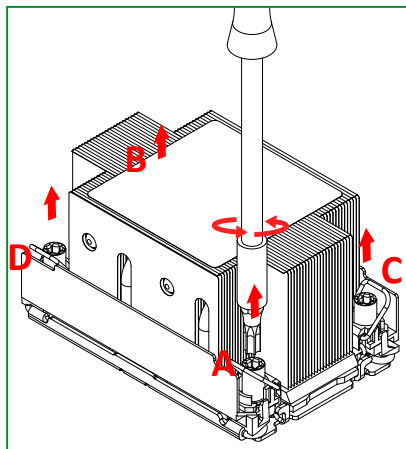


**2U Heatsink**

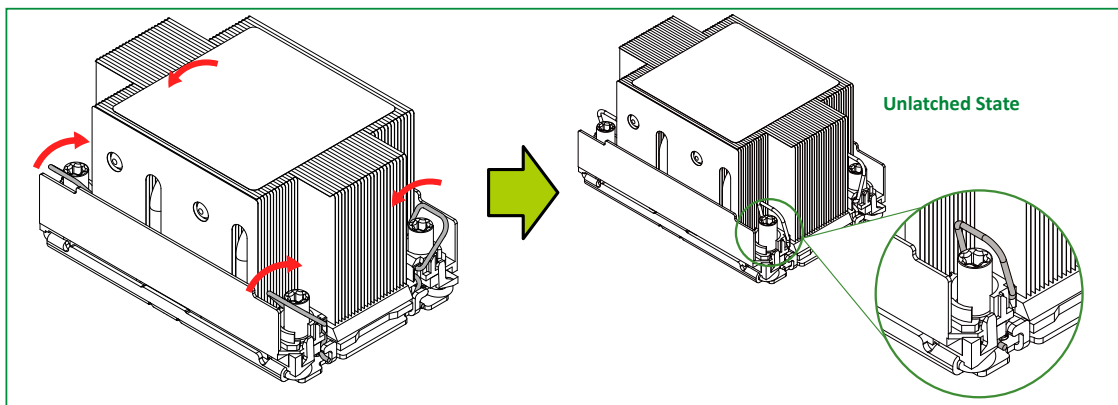
## Removing the PHM from the CPU Socket

Before removing the PHM from the motherboard, be sure to shut down the system and unplug the power cables from the power supply. Then follow the steps below:

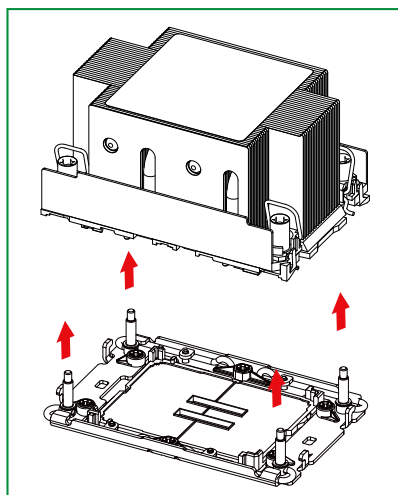
1. Use a T30 driver to loosen the four PEEK nuts on the heatsink in the sequence of A, B, C, and D.



2. Once the PEEK nuts are loosened from the CPU socket, press the rotating wires inwards to unlatch the PHM from the socket as shown in the drawings below.



3. Gently pull the PHM upwards to remove it from the CPU socket.

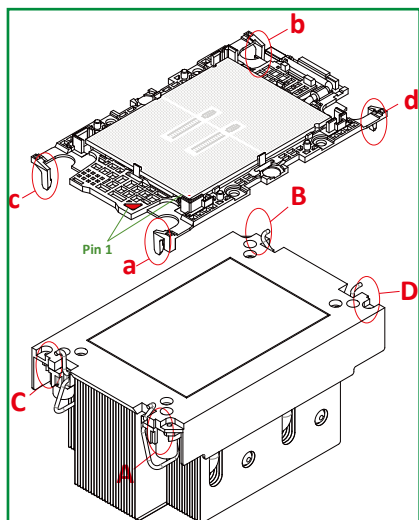


## Removing the Processor Carrier Assembly from the PHM

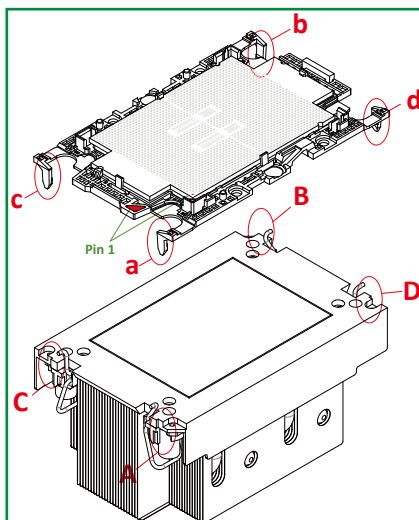
To remove the processor carrier assembly from the PHM, please follow the steps below:

1. Detach the four plastic clips (marked a, b, c, d) on the processor carrier assembly from the four corners of the heatsink (marked A, B, C, D) as shown in the drawings below.

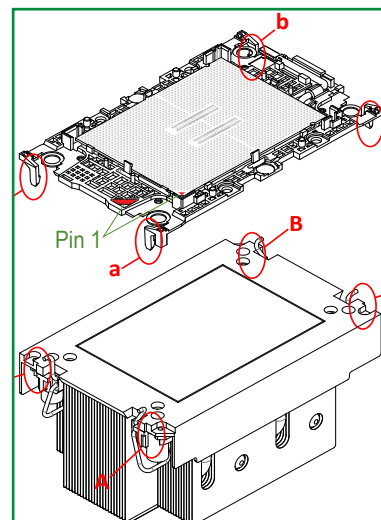
2U Heatsink (View of Component Side & Heatsink Bottom Side)



**SP XCC Series**

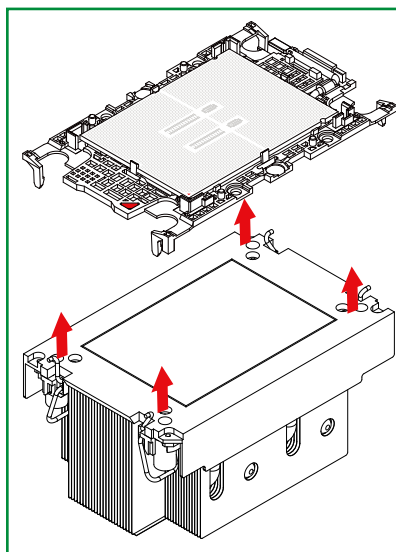


**Max Series (HBM)**

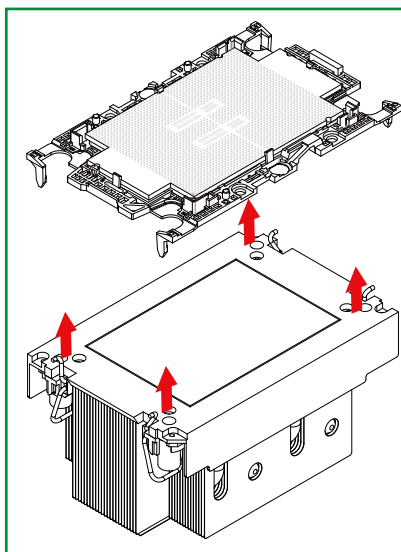


**SP MCC Series**

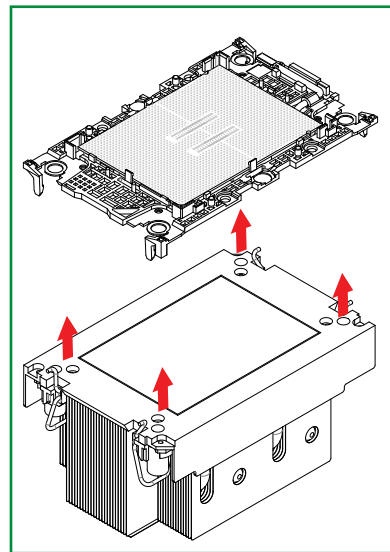
2. When all plastic clips are detached from the heatsink, remove the processor carrier assembly from the heatsink.



**SP XCC Series**



**Max Series (HBM)**



**SP MCC Series**

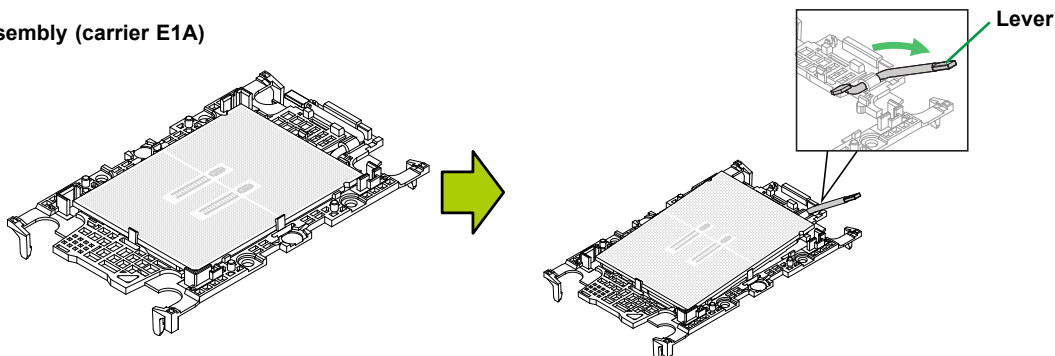


## Removing the Processor from the Processor Carrier Assembly

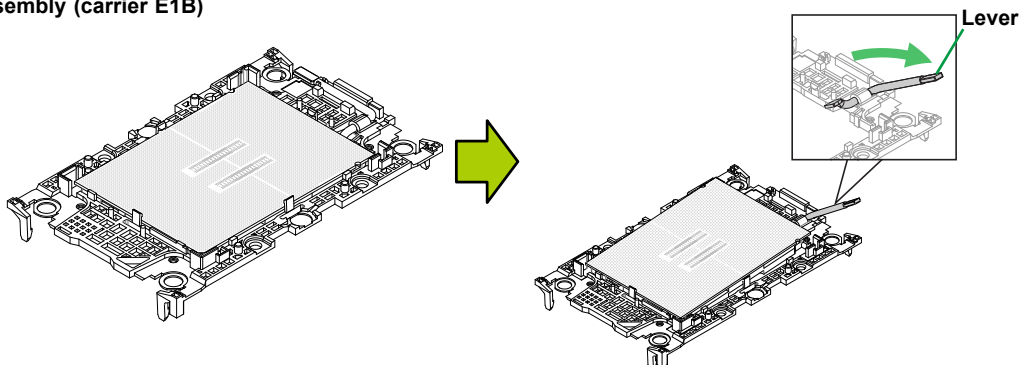
Once you have removed the processor carrier assembly from the PHM, you are ready to remove the processor from the processor carrier by following the steps below.

1. Unlock the lever from its locked position and push the lever upwards to disengage the processor from the processor carrier as shown in the drawing on the right below.

CPU Carrier Assembly (carrier E1A)

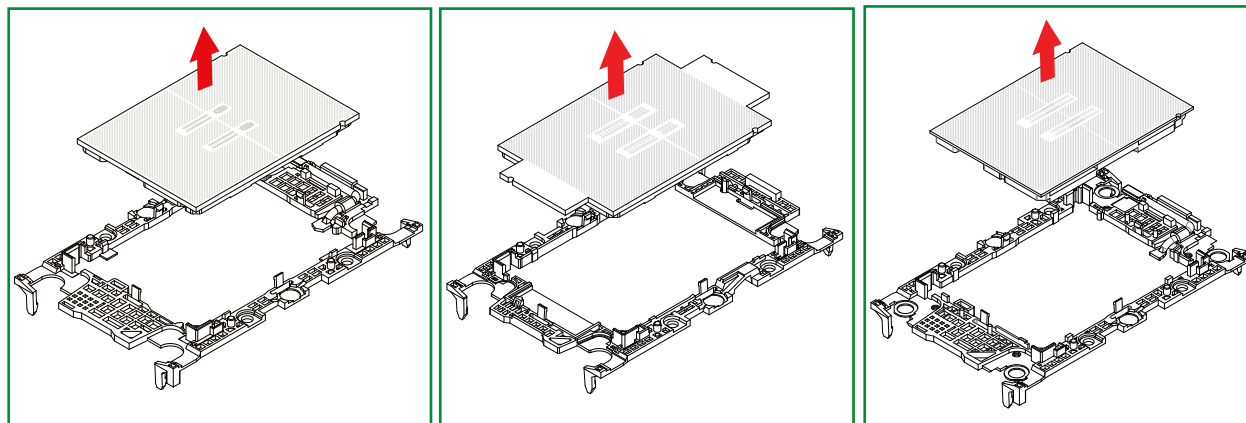


CPU Carrier Assembly (carrier E1B)



2. Once the processor is loosened from the carrier, carefully remove the processor from the processor carrier.

**Note:** Please handle the processor with care to avoid damaging the processor and its pins.



SP XCC Series

Max Series (HBM)

SP MCC Series

## Installing EVAC Heatsinks (Optional)

The optional Extended Volume Air Cooling (EVAC) SNK-P2089P 2U heatsink designed for X13DEM supports dual 4<sup>th</sup> Gen Intel Xeon Scalable Processors (in Socket E LGA4189).

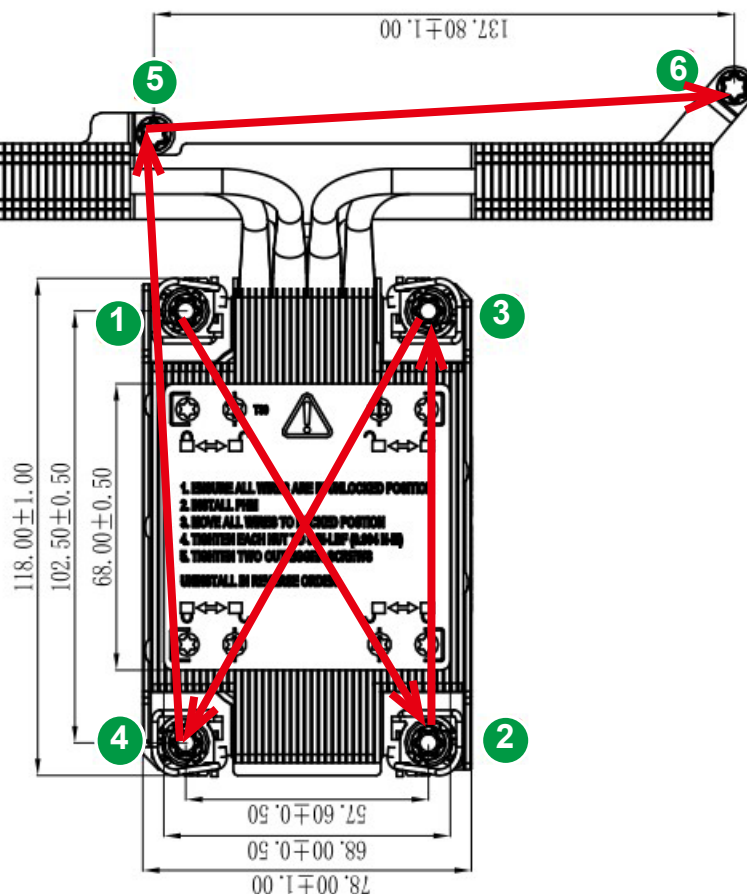
### Installing X13DEM EVAC Heatsinks

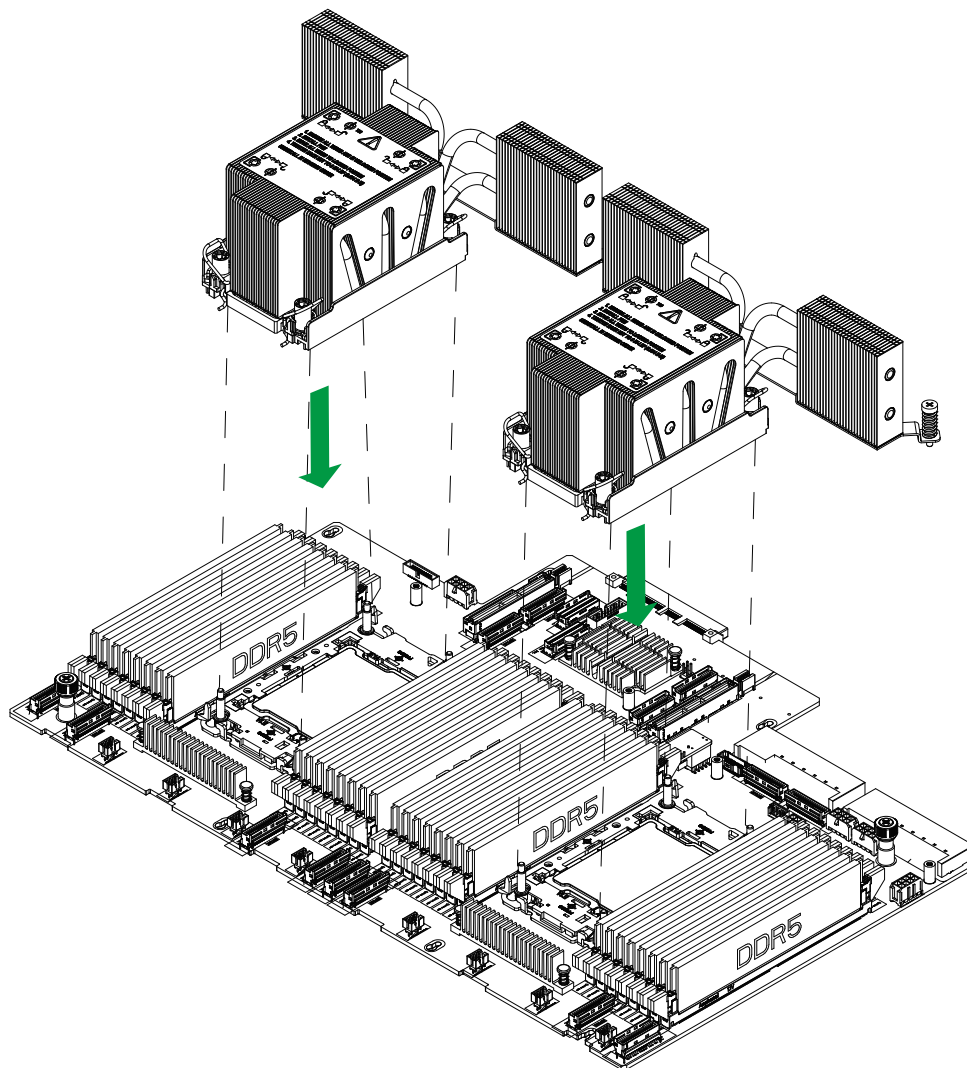
Begin by [creating the PHM](#) and [installing the PHM into the CPU socket](#).

1. With a T30 bit torque driver set to a force of 8.0 in-lbf (0.904 N-m), gradually tighten the six PEEK nuts to ensure even pressure in the sequence of 1-2-3-4-5-6.

**Important:** Do not use a force greater than 8.0 in-lbf (0.904 N-m). Exceeding this force may over-torque the screw, causing damage to the processor, heatsink, and screw.

2. Examine all the extended sections of the heatsinks to ensure that the EVAC heatsink is firmly attached to the standoffs.





**Figure 3-2. Installing X13DEM EVAC Heatsinks (Optional)**

**Note:** To remove the EVAC heatsink from the CPU package, unscrew the screws in the sequence of 6-5-4-3-2-1. To avoid over-tension on PEEK nuts 5 and 6, do not loosen the screws in the order of 1-2-3-4.

## 3.5 Memory Support and Installation

**Note:** Check the Supermicro website for recommended memory modules.

**Important:** Exercise extreme care when installing or removing memory modules to prevent any possible damage.

### Memory Support

This motherboard supports up to 8 TB of 3DS RDIMM/RDIMM DDR5 (288-pin) memory with speeds up to 5600 MT/s. (**Note 1** below). To enhance memory performance, do not mix memory modules of different speeds and sizes. Please follow all memory installation instructions given below.

**Note:** Memory speed/capacity support depends on the processors used in the system. The 4<sup>th</sup> Gen Intel Xeon Scalable processors support DDR5 memory with speeds up to 4800 MT/s (or up to 4400 MT/s in 32-DIMM configuration). The 5<sup>th</sup> Gen Intel Xeon Scalable processors support DDR5 memory with speeds up to 5600 MT/s (or up to 4400 MT/s in 32-DIMM configuration).

### *DDR5 Memory Support for 4<sup>th</sup> and 5<sup>th</sup> Gen Intel Xeon Scalable Processors*

For your system memory to work properly, please follow the memory population tables below to install the memory modules on your motherboard. These memory population tables were created based on the general memory population guidelines provided by Intel to support Supermicro X13DP motherboards.

DDR5 Memory Support for the 4 <sup>th</sup> Gen Scalable Processors-SP					
Type	Ranks Per DIMM & Data Width (Stack)	DIMM Capacity (GB)		Speed (MT/S)	
				One DIMM per Channel <sup>1</sup>	Two DIMMs per Channel
		Memory Density 16 Gb	Memory Density 24 Gb <sup>2</sup>	1.1 Volts	
RDIMM	SRx8 (RC D)	16 GB	24 GB	4800*	4400*
	SRx4 (RC C)	32 GB	48 GB		
	SRx4 (RC F) 9x4	32 GB	N/A		
	DRx8 (RC E)	32 GB	48 GB		
	DRx4 (RC A)	64 GB	96 GB		
	DRx4 (RC B) 9x4	64 GB	N/A		
RDIMM 3DS	(4R/8R) x4 (RC A)	2H-128 GB 4H-256 GB	N/A		

\*Memory speed and capacity support depends on the processors used in the system.

**Note 1:** 1DPC applies to 1SPC or 2SPC implementations (SPC - sockets per channel).

**Note 2:** 24 Gb XCC only with limited configs: 1DPC all DIMM types, 2DPC 96 GB only. Only 8 and 16 DIMM configs, no fallbacks.

DDR5 Memory Support for the 5 <sup>th</sup> Gen Scalable Processors-SP					
Type	Ranks Per DIMM & Data Width (Stack)	DIMM Capacity (GB)		Speed (MT/S)	
				One DIMM per Channel <sup>1</sup>	Two DIMMs per Channel
		Memory Density 16 Gb	Memory Density 24 Gb <sup>2</sup>	1.1 Volts	
RDIMM	SRx8 (RC D)	16 GB	24 GB	5600*	4400*
	SRx4 (RC C)	32 GB	48 GB		
	SRx4 (RC F) 9x4	N/A	N/A		
	DRx8 (RC E)	32 GB	48 GB		
	DRx4 (RC A)	64 GB	96 GB		
	DRx4 (RC B) 9x4	N/A	N/A		
RDIMM 3DS	(4R/8R) x4 (RC A)	2H-128 GB 4H-256 GB	N/A		

\*Memory speed and capacity support depends on the processors used in the system.

**Note 1:** 1DPC applies to 1SPC or 2SPC implementations (SPC - sockets per channel).

**Note 2:** 24 Gb XCC only with limited configs: 1DPC all DIMM types, 2DPC 96 GB only. Only 8 and 16 DIMM configs, no fallbacks.

**Note 3:** Memory speed will be 5600 MT/s 1DPC or 4400 MT/s 2DPC.

**Note 4:** For 1DPC 5600 MT/s speed, DDR5-5600 DIMMs are required.

**Note 5:** Mixing DRAM density (16 Gb/24 Gb) and/or frequency is not allowed.

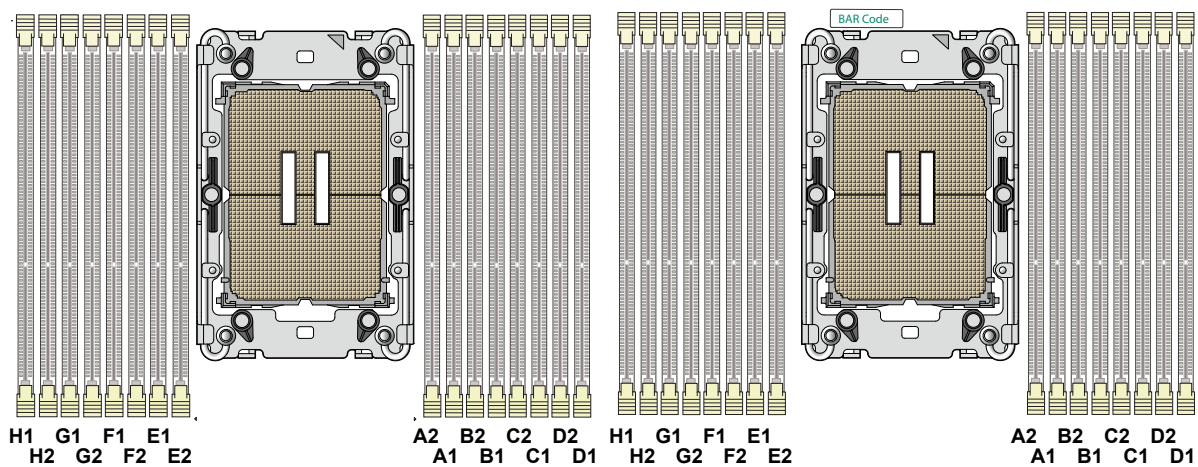


Figure 3-3. Memory Slots

## Memory Population Table for 4<sup>th</sup> and 5<sup>th</sup> Gen Intel Xeon Scalable Processors

Use the DIMM slots listed below for memory modules. This memory population table is based on guidelines provided by Intel to support Supermicro motherboards.

DDR5 Memory Population Table (with SPXCC & MCC CPUs and 32 DIMMs Installed)	
<b>1 CPU:</b>	<b>Memory Population Sequence</b>
<b>1 CPU &amp; 1 DIMM</b>	P1-DIMMA1 P1-DIMME1 P1-DIMMB1 P1-DIMMF1
<b>1 CPU &amp; 2 DIMMs</b>	P1-DIMMA1/P1-DIMMG1 P1-DIMMC1/P1-DIMME1
<b>1 CPU &amp; 4 DIMMs</b>	P1-DIMMA1/P1-DIMMC1/P1-DIMME1/P1-DIMMG1
<b>1 CPU &amp; 6 DIMMs</b>	P1-DIMMA1/P1-DIMMC1/P1-DIMMD1/P1-DIMME1/P1-DIMMF1/P1-DIMMG1 P1-DIMMA1/P1-DIMMB1/P1-DIMMC1/P1-DIMME1/P1-DIMMG1/P1-DIMMH1 P1-DIMMB1/P1-DIMMC1/P1-DIMMD1/P1-DIMME1/P1-DIMMF1/P1-DIMMH1 P1-DIMMA1/P1-DIMMB1/P1-DIMMD1/P1-DIMMF1/P1-DIMMG1/P1-DIMMH1
<b>1 CPU &amp; 8 DIMMs</b>	P1-DIMMA1/P1-DIMMB1/P1-DIMMC1/P1-DIMMD1/P1-DIMME1/P1-DIMMF1/P1-DIMMG1/P1-DIMMH1
<b>1 CPU &amp; 12 DIMMs</b>	P1-DIMMA1/P1-DIMMB1/P1-DIMMC1/P1-DIMMD1/P1-DIMME1/P1-DIMMF1/P1-DIMMG1/P1-DIMMH1/P1-DIMMA2/P1-DIMMA1/P1-DIMMA2/P1-DIMMB1/ P1-DIMMC1/P1-DIMMC2/P1-DIMMD1/P1-DIMME1/P1-DIMME2/P1-DIMMF1/P1- DIMMG1/P1-DIMMG2/P1-DIMMH1 P1-DIMMA1/P1-DIMMB1/P1-DIMMB2/P1-DIMMC1/P1-DIMMD1/P1-DIMMD2/P1-DIMME1/P1-DIMMF1/P1-DIMMF2/P1- DIMMG1/P1-DIMMH1/P1-DIMMH2
<b>1 CPU &amp; 16 DIMM</b>	P1-DIMMA1/P1-DIMMA2/P1-DIMMB1/P1-DIMMB2/P1-DIMMC1/P1-DIMMC2/P1-DIMMD1/P1-DIMMD2/P1-DIMME1/P1- DIMME2/P1-DIMMF1/P1-DIMMF2/P1-DIMMG1/P1-DIMMG2/P1-DIMMH1/P1-DIMMH2
<b>2 CPUs: (Recommended)</b>	<b>Memory Population Sequence</b>
<b>2 CPUs &amp; 2 DIMMs</b>	<b>CPU1:</b> P1-DIMMA1, <b>CPU2:</b> P2-DIMMA1 <b>CPU1:</b> P1-DIMME1, <b>CPU2:</b> P2-DIMME1 <b>CPU1:</b> P1-DIMMB1, <b>CPU2:</b> P2-DIMMB1 <b>CPU1:</b> P1-DIMMF1, <b>CPU2:</b> P2-DIMMF1
<b>2 CPUs &amp; 4 DIMMs</b>	<b>CPU1:</b> P1-DIMMA1/P1-DIMMG1, <b>CPU2:</b> P2-DIMMA1/P2-DIMMG1 <b>CPU1:</b> P1-DIMMC1/P1-DIMME1, <b>CPU2:</b> P2-DIMMC1/P2-DIMME1
<b>2 CPUs &amp; 8 DIMMs</b>	<b>CPU1:</b> P1-DIMMA1/P1-DIMMC1/P1-DIMME1/P1-DIMMG1 <b>CPU2:</b> P2-DIMMA1/P2-DIMMC1/P2-DIMME1/P2-DIMMG1
<b>2 CPUs &amp; 10 DIMMs</b>	<b>CPU1:</b> P1-DIMMA1/P1-DIMMC1/P1-DIMMD1/P1-DIMME1/P1-DIMMF1/P1-DIMMG1 <b>CPU2:</b> P2-DIMMA1/P2-DIMMC1/P2-DIMME1/P2-DIMMG1
<b>2 CPUs &amp; 12 DIMMs</b>	<b>CPU1:</b> P1-DIMMA1/P1-DIMMC1/P1-DIMMD1/P1-DIMME1/P1-DIMMF1/P1-DIMMG1 <b>CPU2:</b> P2-DIMMA1/P2-DIMMC1/P2-DIMMD1/P2-DIMME1/P2-DIMMF1/P2-DIMMG1  <b>CPU1:</b> P1-DIMMA1/P1-DIMMB1/P1-DIMMC1/P1-DIMME1/P1-DIMMG1/P1-DIMMH1 <b>CPU2:</b> P2-DIMMA1/P2-DIMMB1/P2-DIMMC1/P2-DIMME1/P2-DIMMG1/P2-DIMMH1  <b>CPU1:</b> P1-DIMMB1/P1-DIMMC1/P1-DIMMD1/P1-DIMME1/P1-DIMMF1/P1-DIMMH1 <b>CPU2:</b> P2-DIMMB1/P2-DIMMC1/P2-DIMMD1/P2-DIMME1/P2-DIMMF1/P2-DIMMH1  <b>CPU1:</b> P1-DIMMA1/P1-DIMMB1/P1-DIMMD1/P1-DIMMF1/P1-DIMMG1/P1-DIMMH1 <b>CPU2:</b> P2-DIMMA1/P2-DIMMB1/P2-DIMMD1/P2-DIMMF1/P2-DIMMG1/P2-DIMMH1
<b>2 CPUs &amp; 16 DIMMs</b>	<b>CPU1:</b> P1-DIMMA1/P1-DIMMB1/P1-DIMMC1/P1-DIMMD1/P1-DIMME1/P1-DIMMF1/P1-DIMMG1/P1-DIMMH1 <b>CPU2:</b> P2-DIMMA1/P2-DIMMB1/P2-DIMMC1/P2-DIMMD1/P2-DIMME1/P2-DIMMF1/P2-DIMMG1/P2-DIMMH1
<b>2 CPUs &amp; 22 DIMMs</b>	<b>CPU1:</b> P1-DIMMA1/P1-DIMMA2/P1-DIMMB1/P1-DIMMB2/P1-DIMMC1/P1-DIMMC2/P1-DIMMD1/P1-DIMMD2/P1- DIMME1/P1-DIMME2/P1-DIMMF1/P1-DIMMF2/P1-DIMMG1/P1-DIMMG2/P1-DIMMH1/P1-DIMMH2 <b>CPU2:</b> P2-DIMMA1/P2-DIMMC1/P2-DIMMD1/P2-DIMME1/P2-DIMMF1/P2-DIMMG1
<b>2 CPUs &amp; 24 DIMMs</b>	<b>CPU1:</b> P1-DIMMA1/P1-DIMMA2/P1-DIMMB1/P1-DIMMB2/P1-DIMMC1/P1-DIMMC2/P1-DIMMD1/P1-DIMMD2/P1- DIMME1/P1-DIMME2/P1-DIMMF1/P1-DIMMF2/P1-DIMMG1/P1-DIMMG2/P1-DIMMH1/P1-DIMMH2 <b>CPU2:</b> P2-DIMMA1/P2-DIMMA2/P2-DIMMB1/P2-DIMMB2/P2-DIMMC1/P2-DIMMC2/P2-DIMMD1/P2-DIMMD2/P2- DIMME1/P2-DIMME2/P2-DIMMF1/P2-DIMMF2/P2-DIMMG1/P2-DIMMG2/P2-DIMMH1/P2-DIMMH2
<b>2 CPUs &amp; 32 DIMMs</b>	<b>CPU1:</b> P1-DIMMA1/P1-DIMMA2/P1-DIMMB1/P1-DIMMB2/P1-DIMMC1/P1-DIMMC2/P1-DIMMD1/P1-DIMMD2/P1- DIMME1/P1-DIMME2/P1-DIMMF1/P1-DIMMF2/P1-DIMMG1/P1-DIMMG2/P1-DIMMH1/P1-DIMMH2 <b>CPU2:</b> P2-DIMMA1/P2-DIMMA2/P2-DIMMB1/P2-DIMMB2/P2-DIMMC1/P2-DIMMC2/P2-DIMMD1/P2-DIMMD2/P2- DIMME1/P2-DIMME2/P2-DIMMF1/P2-DIMMF2/P2-DIMMG1/P2-DIMMG2/P2-DIMMH1/P2-DIMMH2

DDR5 Memory Population Table (with Max Series ((HBM)) CPUs and 32 DIMMs Installed)	
<b>1 CPU:</b>	<b>Memory Population Sequence</b>
1 CPU & 1 DIMM	P1-DIMMA1 P1-DIMME1
1 CPU & 2 DIMMs	P1-DIMMA1/P1-DIMMG1 P1-DIMMC1/P1-DIMME1
1 CPU & 4 DIMMs	P1-DIMMA1/P1-DIMMC1/P1-DIMME1/P1-DIMMG1
1 CPU & 8 DIMMs	P1-DIMMA1/P1-DIMMB1/P1-DIMMC1/P1-DIMMD1/P1-DIMME1/P1-DIMMF1/P1-DIMMG1/P1-DIMMH1
1 CPU & 16 DIMMs	P1-DIMMA1/P1-DIMMA2/P1-DIMMB1/P1-DIMMB2/P1-DIMMC1/P1-DIMMC2/P1-DIMMD1/P1-DIMMD2/P1-DIMME1/P1-DIMME2/P1-DIMMF1/P1-DIMMF2/P1-DIMMG1/P1-DIMMG2/P1-DIMMH1/P1-DIMMH2
<b>2 CPUs: (Recommended)</b>	<b>Memory Population Sequence</b>
2 CPUs & 2 DIMMs	<b>CPU1:</b> P1-DIMMA1, CPU2: P2-DIMMA1 <b>CPU1:</b> P1-DIMME1, CPU2: P2-DIMME1
2 CPUs & 4 DIMMs	<b>CPU1:</b> P1-DIMMA1/P1-DIMMG1, CPU2: P2-DIMMA1/P2-DIMMG1 <b>CPU1:</b> P1-DIMMC1/P1-DIMME1, CPU2: P2-DIMMC1/P2-DIMME1
2 CPUs & 8 DIMMs	<b>CPU1:</b> P1-DIMMA1/P1-DIMMC1/P1-DIMME1/P1-DIMMG1 <b>CPU2:</b> P2-DIMMA1/P2-DIMMC1/P2-DIMME1/P2-DIMMG1
2 CPUs & 16 DIMMs	<b>CPU1:</b> P1-DIMMA1/P1-DIMMB1/P1-DIMMC1/P1-DIMMD1/P1-DIMME1/P1-DIMMF1/P1-DIMMG1/P1-DIMMH1 <b>CPU2:</b> P2-DIMMA1/P2-DIMMB1/P2-DIMMC1/P2-DIMMD1/P2-DIMME1/P2-DIMMF1/P2-DIMMG1/P2-DIMMH1
2 CPUs & 32 DIMMs	<b>CPU1:</b> P1-DIMMA1/P1-DIMMA2/P1-DIMMB1/P1-DIMMB2/P1-DIMMC1/P1-DIMMC2/P1-DIMMD1/P1-DIMMD2/P1-DIMME1/P1-DIMME2/P1-DIMMF1/P1-DIMMF2/P1-DIMMG1/P1-DIMMG2/P1-DIMMH1/P1-DIMMH2 <b>CPU2:</b> P2-DIMMA1/P2-DIMMA2/P2-DIMMB1/P2-DIMMB2/P2-DIMMC1/P2-DIMMC2/P2-DIMMD1/P2-DIMMD2/P2-DIMME1/P2-DIMME2/P2-DIMMF1/P2-DIMMF2/P2-DIMMG1/P2-DIMMG2/P2-DIMMH1/P2-DIMMH2

**Notes:**

- Max Series (HBM) CPU supports 1DPC (4800MT/s) / 2DPC (4400MT/s) to optimize the memory bandwidth. Max Series (HBM) CPU supports 1, 2, 4, 8, or 16 DIMMs in Flat Mode as well as Cache Mode, and 0 DIMMs in HBM-Only mode. HBM-Only mode runs exclusively using HBM memory.
- For the best memory performance in Flat mode and Cache mode, please use 4, 8, or 16 DIMM configurations. (At least one DIMM per memory controller for balanced configuration)

*4 DIMMs -> populate 1 DIMM/iMC (Integrated Memory Controller)*

*8 DIMMs -> populate 1 DIMM/Channel, 2 DIMM/iMC*

*16 DIMMs -> populate 2 DIMM/Channel, 4 DIMM/iMC*

- All other configurations not listed above are not supported.
- For the 2-socket design, each socket has to be populated identically.



## **Memory Population Guidelines**

- All DIMMs must be DDR5.
- Balanced memory. Using unbalanced memory topology, such as populating two DIMMs in one channel while populating one DIMM in another channel, reduces performance. It is not recommended for Supermicro systems.
- In single-CPU configurations, memory must be installed in the DIMM slots associated with the installed CPU.
- For MM, NM/FM ratio is between 1:4 and 1:16. The capacity not used for FM can be used for AD. (NM = Near Memory; FM = Far Memory).

## ***Guidelines Regarding Mixing DIMMs***

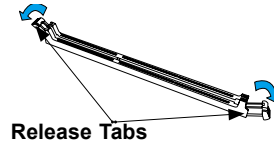
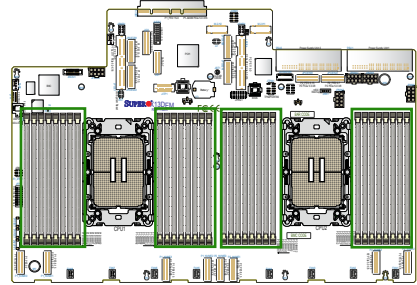
- Populating slots with a pair of DIMM modules of the same type and size results in interleaved memory, which improves memory performance.
- Use memory modules of the same type and speed, as mixing is not allowed.
- x4 and x8 DIMMs can be mixed in the same channel.

## ***DIMM Construction***

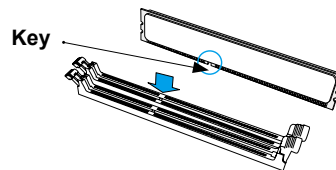
- RDIMM (non-3DS) Raw Cards: A/B (2Rx4), C (1Rx4), D (1Rx8), E (2Rx8)
- 3DS RDIMM Raw Cards: A/B (4Rx4)
- LRDIMM (non-3DS) Raw Cards: D/E (4Rx4)
- 3DS LRDIMM Raw Cards: A/B (8Rx4)

## DIMM Installation

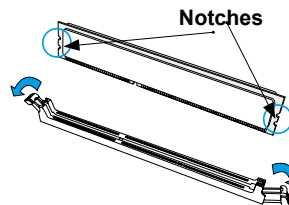
1. Insert the desired number of DIMMs into the memory slots based on the recommended DIMM population tables in the previous section. Locate DIMM memory slots on the motherboard as shown on the right.
2. Push the release tabs outwards on both ends of the DIMM slot to unlock it.



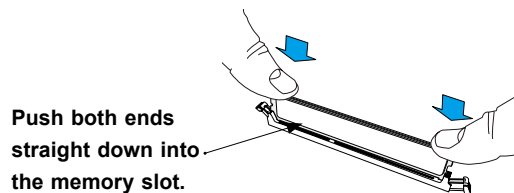
3. Align the key of the memory module with the receptive point on the memory slot.



4. Align the notches on both ends of the module against the receptive points on the ends of the slot.

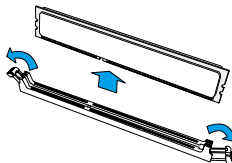


5. Push both ends of the module straight down into the slot until the module snaps into place.
6. Press the release tabs to the lock positions to secure the memory module into the slot.



## DIMM Removal

Press both release tabs on the ends of the memory module to unlock it. Once the memory module has been loosened, remove it from the memory slot.



**Warning!** Please do not use excessive force when pressing the release tabs on the ends of the DIMM socket to avoid causing any damage to the memory module or the DIMM socket. Please handle memory modules with care. Carefully follow all the instructions given on page 1 of this chapter to avoid ESD-related damages done to your memory modules or components.

## 3.6 Motherboard Battery

### Battery Removal

**To remove the onboard battery, follow the steps below:**

1. Power off your system and unplug your power cable.
2. Locate the onboard battery as shown below.
3. Using a tool such as a pen or a small screwdriver, push the battery lock outwards to unlock it. Once unlocked, the battery will pop out from the holder.
4. Remove the battery.

### Proper Battery Disposal

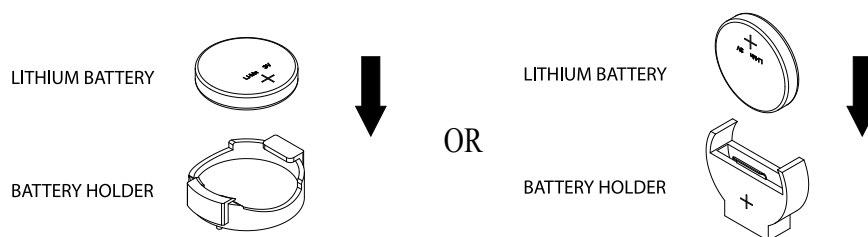
**Warning:** Please handle used batteries carefully. Do not damage the battery in any way; a damaged battery may release hazardous materials into the environment. Do not discard a used battery in the garbage or a public landfill. Please comply with the regulations set up by your local hazardous waste management agency to dispose of your used battery properly.

### Battery Installation

**To install an onboard battery, follow the steps below:**

1. Power off your system and unplug your power cable.
2. Locate the onboard battery as shown below
3. Identify the battery's polarity. The positive (+) side should be facing up.
4. Insert the battery into the battery holder and push it down until you hear a click to ensure that the battery is securely locked.

**Warning:** When replacing a battery, be sure to only replace it with the same type.



## 3.7 Storage Drives

The storage drives are mounted in tool-less drive carriers that simplify their removal from the chassis. These carriers also help promote proper airflow. For compatible storage drives, see the SYS-221H-TNR and SYS-221H-TN24R product page.



Figure 3-4. Logical Drive Numbers

### *Removing a Hot-Swap Drive Carrier from the Chassis*

1. Press the release button on the drive carrier, which will extend the drive carrier handle.
2. Use the drive carrier handle to pull the drive out of the chassis.

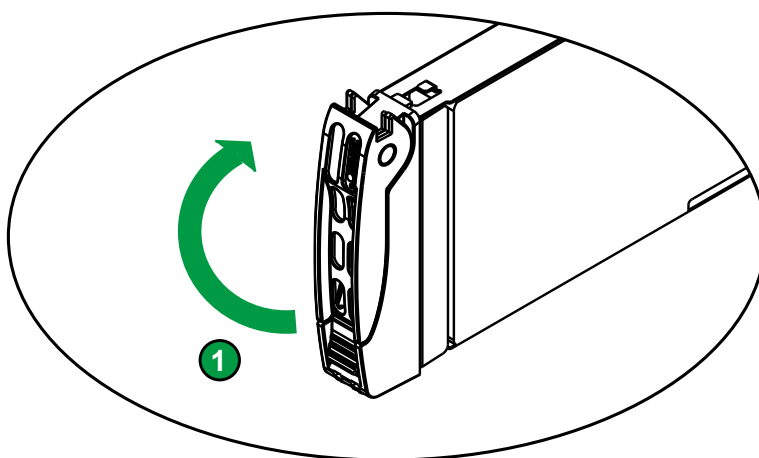


Figure 3-5. Removing a Drive Carrier

## Hot-Swap for NVMe Drives

Supermicro servers support NVMe surprise hot-swap. For even better data security, NVMe orderly hot-swap is recommended. NVMe drives can be ejected and replaced remotely using BMC.

**Note:** If you are using VROC, see the VROC appendix in this manual instead.

### Ejecting a Drive

1. **BMC > Server Health > NVMe SSD**
2. Select Device, Group, and Slot, and click **Eject**. After ejecting, the drive Status LED indicator turns green.
3. Remove the drive.

Note that Device and Group are categorized by the CPLD design architecture.

A Slot is the slot number on which the NVMe drives are mounted.

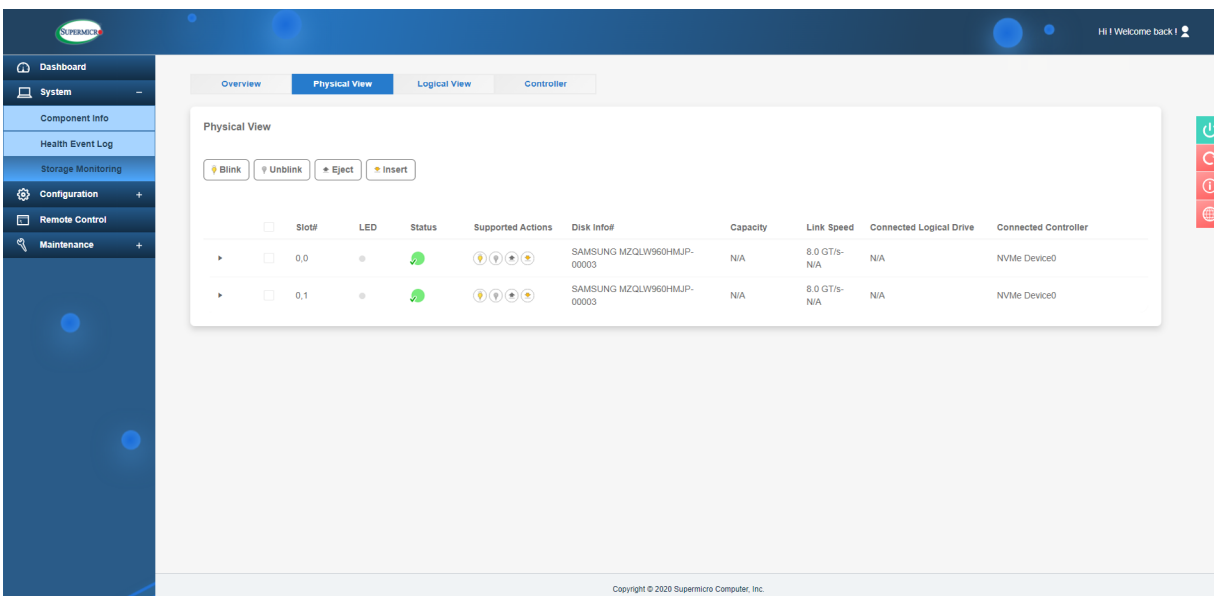


Figure 3-6. BMC Screenshot

### Replacing the Drive

1. Insert the replacement drive.
2. **BMC > System > Storage Monitor > Physical View**
3. Select Device, Group, and slot and click **Insert**. The drive Status LED indicator flashes red, then turns off. The Activity LED turns blue.

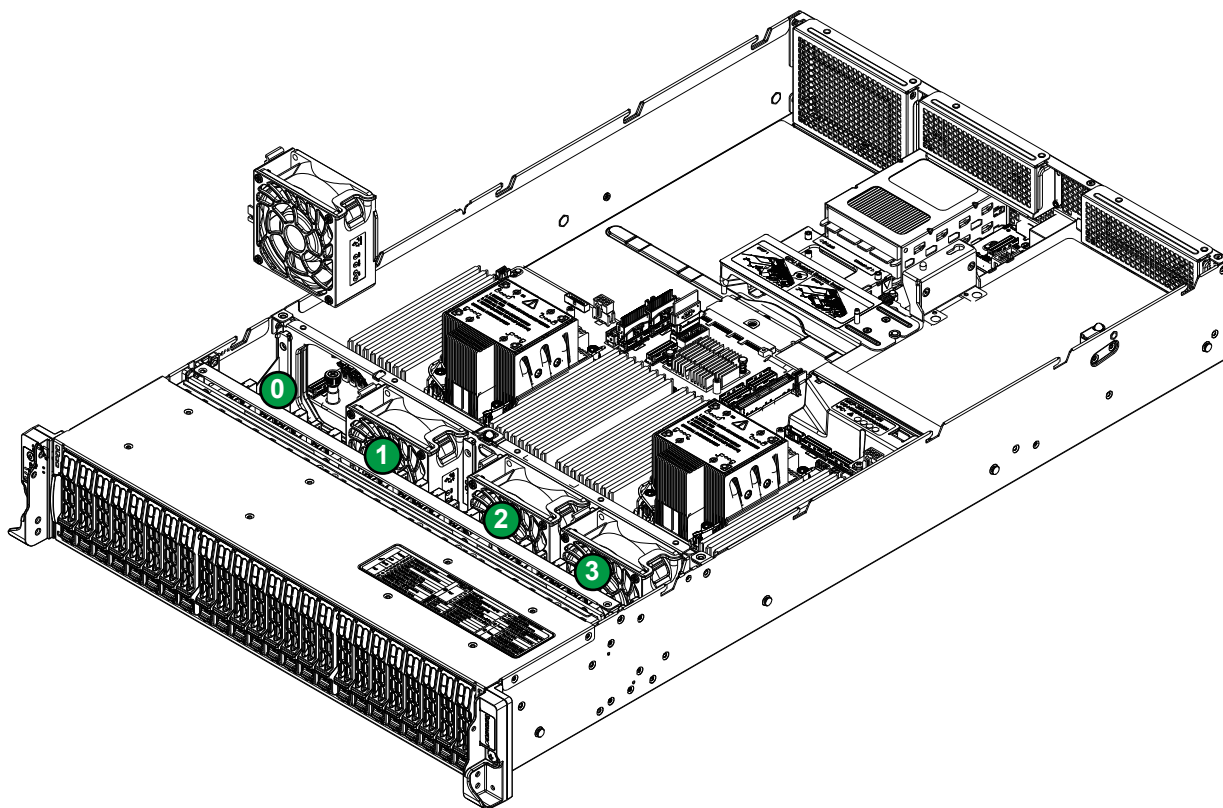
## 3.8 System Cooling

### Fans

The chassis contains four 8-cm hot-swap high-performance fans. Fan speed is controlled by the BMC depending on the system temperature. If a fan fails, the remaining fans will ramp up to full speed. Replace any failed fan at your earliest convenience with the same model. Failed fans can be identified through the BMC.

#### *Changing a System Fan*

1. Determine which fan is failing using BMC if possible. If not, remove the chassis cover while the power is on and examine the fans to determine which one has failed.
2. Squeeze the fan tabs of the failed fan and lift the fan housing up and out of the chassis.
3. To install a fan, push it into the proper location until it clicks.
4. Finish by fully closing the cover and pushing the system back into the rack.



**Figure 3-7. Installing a Fan (positions indicated)**

## Air Shrouds

Air shrouds concentrate airflow to maximize fan efficiency. The SYS-221H-T Series includes one air shroud for each CPU.

### *Air Shroud for Memory (CPU1/2)*

Two air shrouds cool the DIMM slots controlled by CPUs 1 and 2 (see figure below).

1. Remove the system from the rack and remove the cover as described [previously](#).
2. Place each air shroud over sixteen DIMM slots at a time for both CPU1 and CPU2-controlled DIMM slots, as illustrated below.
3. Close the cover and push the system back into the rack.

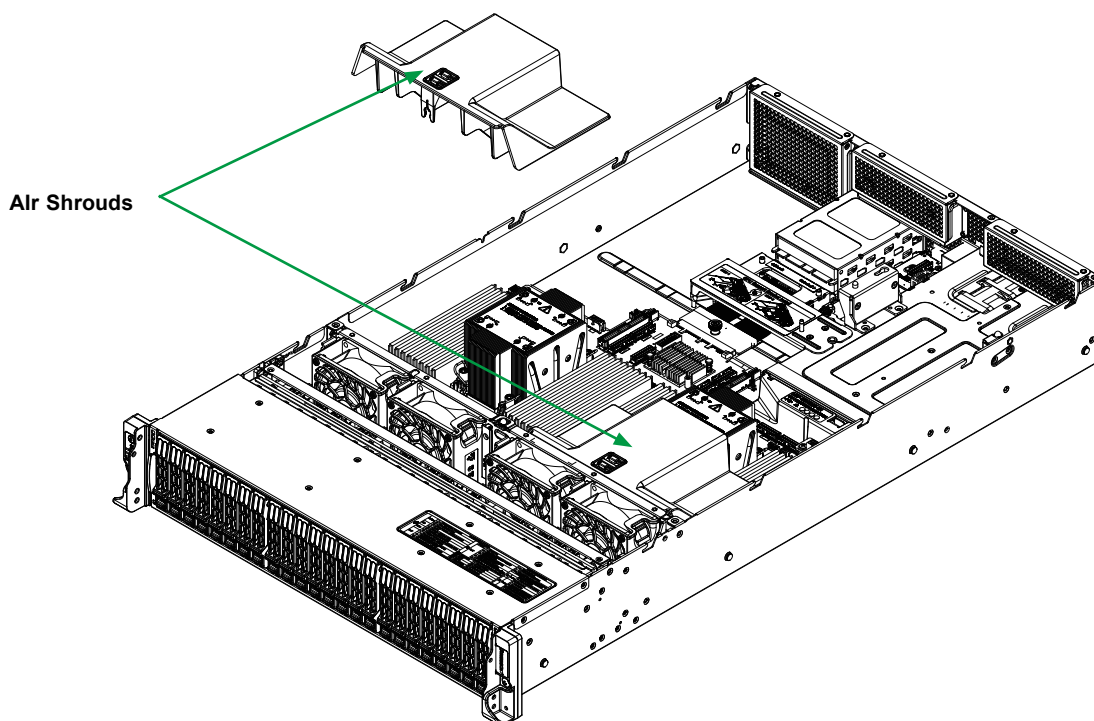
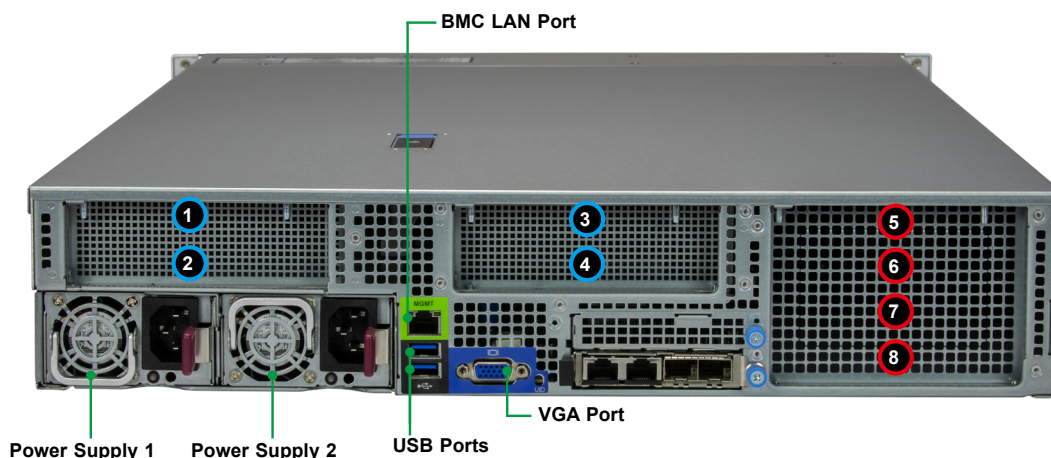


Figure 3-8. Installing Air Shrouds for CPU1/2 DIMMs

## 3.9 Expansion Cards

The SYS-221H-T Series series can support up to eight expansion cards.



**Figure 3-9. Expansion Card Slots**

### Expansion Card Slot Configurations

Enabling any of the eight expansion card slots in this system requires optional parts that are sold separately. See below for expansion card slot configuration ordering information.

Each expansion card slot is assigned to specific motherboard PCIe x8 MCIO connectors or PCIe x16 slots. The following table shows the possible expansion card slot configuration options and the corresponding motherboard PCIe connector assignment.

Expansion Card Slot Configurations		
Slot Configurations	Slot Width	Motherboard Connection
Up to eight PCIe x8 slots	Slot 1: PCIe x8	Cable connection from JPCIE5A1 (CPU2)
	Slot 2: PCIe x8	Cable connection from JPCIE5B1 (CPU2)
	Slot 3: PCIe x8	Cable connection from JPCIE4 (CPU2)
	Slot 4: PCIe x8	Cable connection from JPCIE4 (CPU2)
	Slot 5: PCIe x8	Cable connection from JPCIE2A1 (CPU1)
	Slot 6: PCIe x8	Cable connection from JPCIE2B1 (CPU1)
	Slot 7: PCIe x8	Edge connection from JPCIE1 (CPU1)
	Slot 8: PCIe x8	Edge connection from JPCIE1 (CPU1)
Up to four PCIe x16 slots	Slot 1: PCIe x16	Cable connection from JPCIE5A1 + JPCIE5B1 (CPU2)
	Slot 2: No connection	No connection
	Slot 3: PCIe x16	Cable connection from JPCIE4 (CPU2)
	Slot 4: No connection	No connection
	Slot 5: PCIe x16	Cable connection from JPCIE2A1 + JPCIE2B1 (CPU1)
	Slot 6: No connection	No connection
	Slot 7: PCIe x16	Edge connection from JPCIE1 (CPU1)
	Slot 8: No connection	No connection

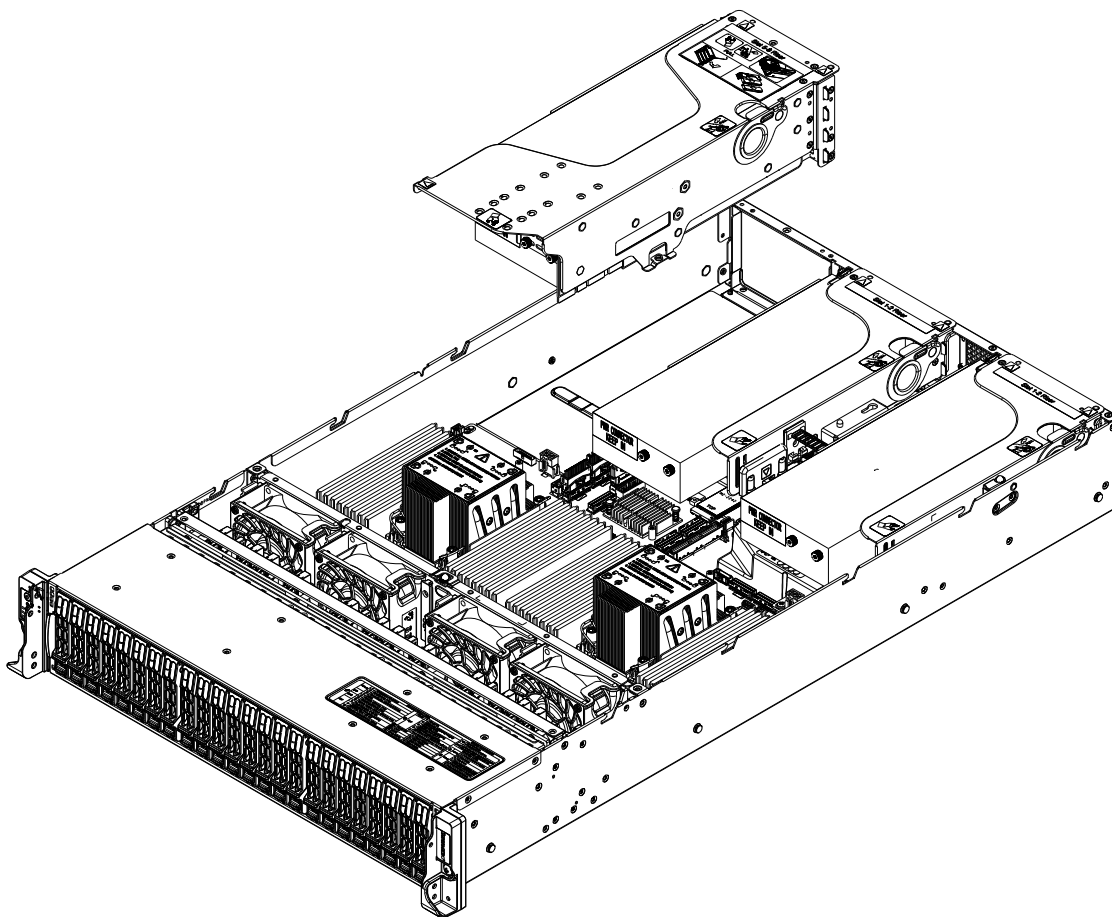
CPU1 ■  
CPU2 ■



Before following the procedure below to install expansion cards, first turn off and remove power from the system as described in [Section 3.1](#) then remove the top cover.

### ***Installing Expansion Cards***

1. Remove any slimline SAS cables connected to the riser card and pull up the riser card brackets.
2. Looking from the node rear, open the clip of each slot on the right.
3. Remove the blank PCI shield from the chassis.
4. Slide the expansion card shield into the open shield slot while plugging the expansion card into the riser card.



**Figure 3-10. Installing Expansion Cards**

## 3.10 AIOM Network Cards

The system provides network connection by means of up to two AIOMs OCP 3.0 network port cards. The second AIOM slot A2 is optional.

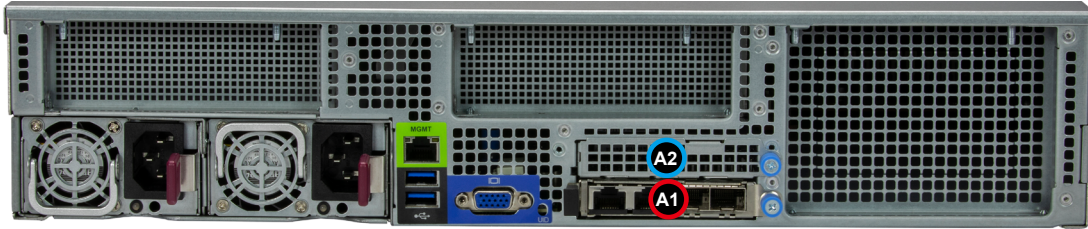


Figure 3-11. AIOM Chassis Slot

AIOM Configuration			
Item	Mechanical	Electrical	Slot Class
<b>A1</b>	Small Form Factor, OCP 3.0	x16 (CPU1)	Up to 50W*
<b>A2</b> (Optional)	Small Form Factor, OCP 3.0	x16 (CPU2)	Up to 35W*

\*AIOM cards exceeding the 15W slot class may require restricted conditions to meet thermal specifications of the AIOM card. Contact your Supermicro account representative for more information.

### Installing AIOM Cards

1. Remove power as described in [Section 3.1](#).
2. Remove the blank cover plate (**A1** or **A2**), unscrewing the thumbscrew.
3. Slide the AIOM card in the opening until it seats in the connector slot.
4. Secure with the thumbscrew.

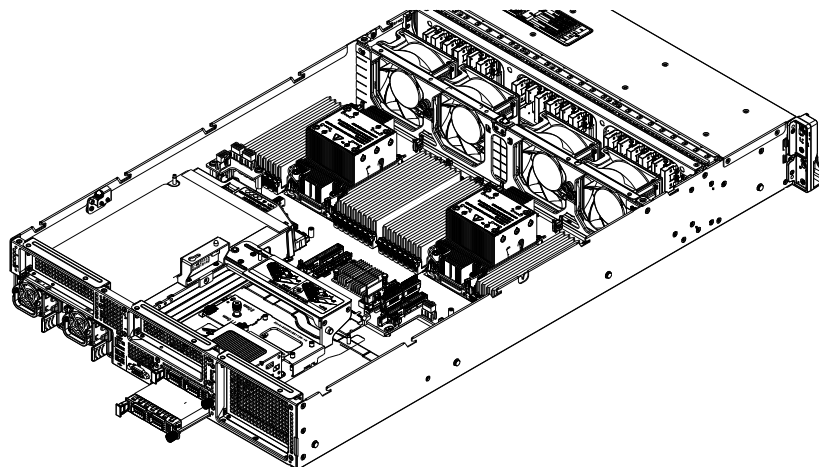
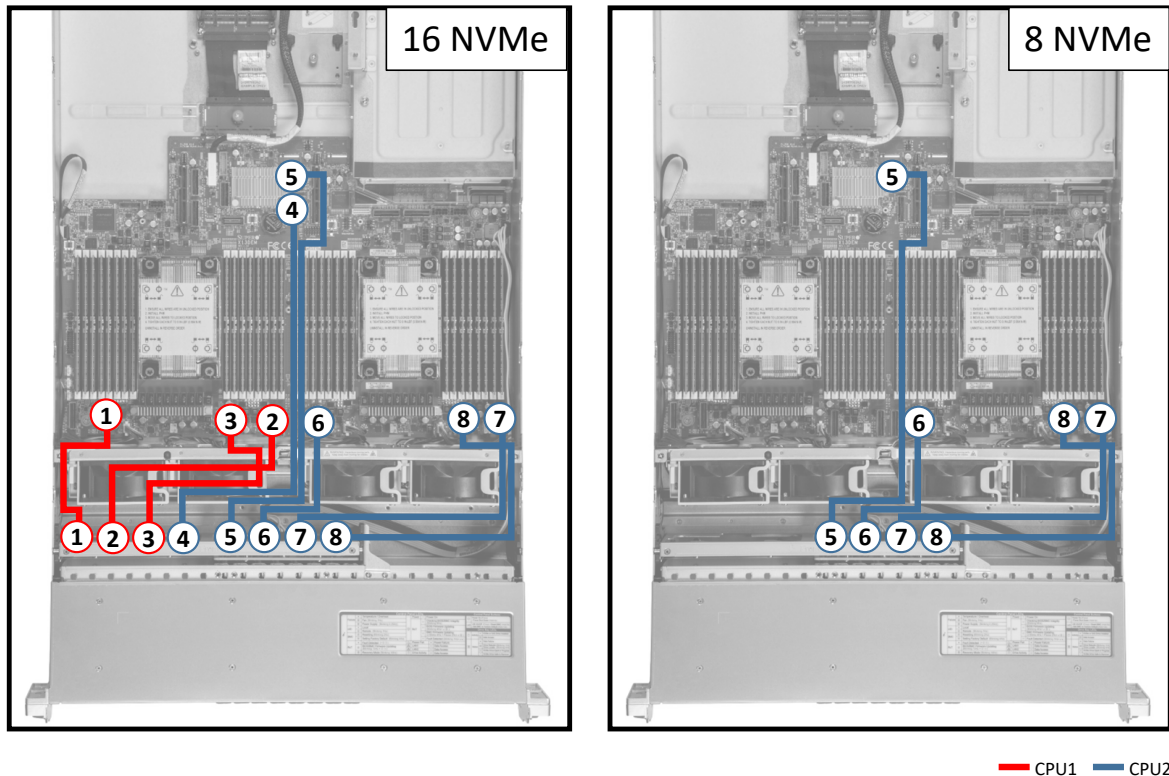


Figure 3-12. Installing AIOMs

## 3.11 Cable Routing Diagrams

The below diagrams indicate the cable routing for the storage, PCIe, IO, and power cables. When disconnecting cables to add or replace components, refer to the diagrams so you can reroute them in the same manner. If cables are not connected or routed properly it may lead to device detection or performance issues.

### SYS-221H-TNR Storage Cables - NVMe

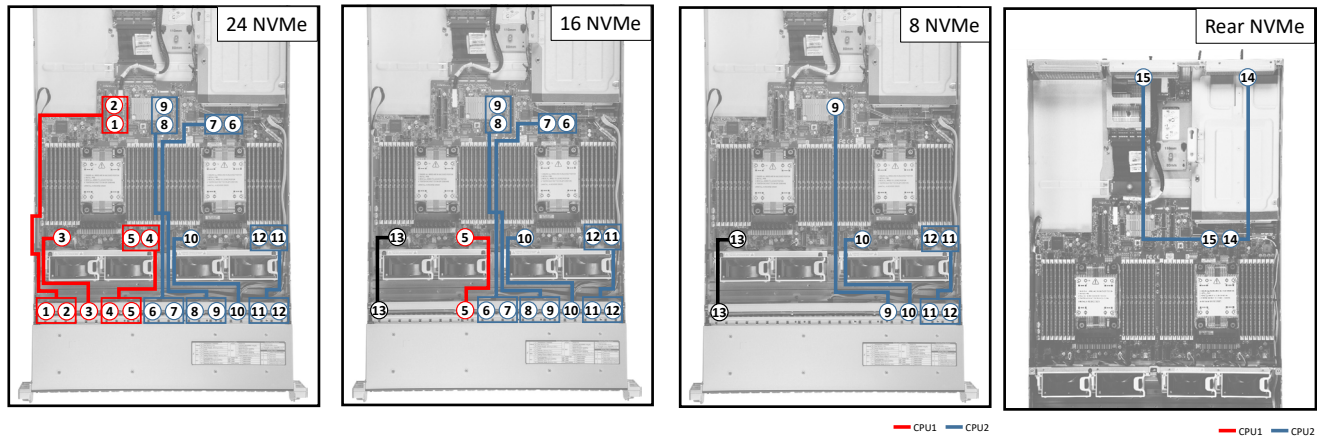


### SYS-221H-TNR Storage Cables - NVMe

Cable	Cable Part Number	Connection From	Connection To
1*	CBL-MCIO-1219M5L	Motherboard, P1_NVME1	Front Backplane (optional), NVME1
2	CBL-MCIO-1229M5LFL	Motherboard, P1_NVME2	Front Backplane (optional), NVME2
3	CBL-MCIO-1234M5L	Motherboard, P1_NVME3	Front Backplane (optional), NVME3
4	CBL-MCIO-1252M5FLE	Motherboard, JPCIE3A1	Front Backplane (optional), NVME4
5*	CBL-MCIO-1252M5FLE	Motherboard, JPCIE3B1	Front Backplane (primary), NVME1
6	CBL-MCIO-1219M5L	Motherboard, P2_NVME1	Front Backplane (primary), NVME2
7	CBL-MCIO-1234AM5LFRE	Motherboard, P2_NVME2	Front Backplane (primary), NVME3
8	CBL-MCIO-1234M5L	Motherboard, P2_NVME3	Front Backplane (primary), NVME4

\*This cable connection provides a NVMe SMBus & NVMe VPP bus communication links between the system and the storage backplane. NVMe devices attached to the storage backplane may have detection or hot-swap issues if this cable not connected properly.

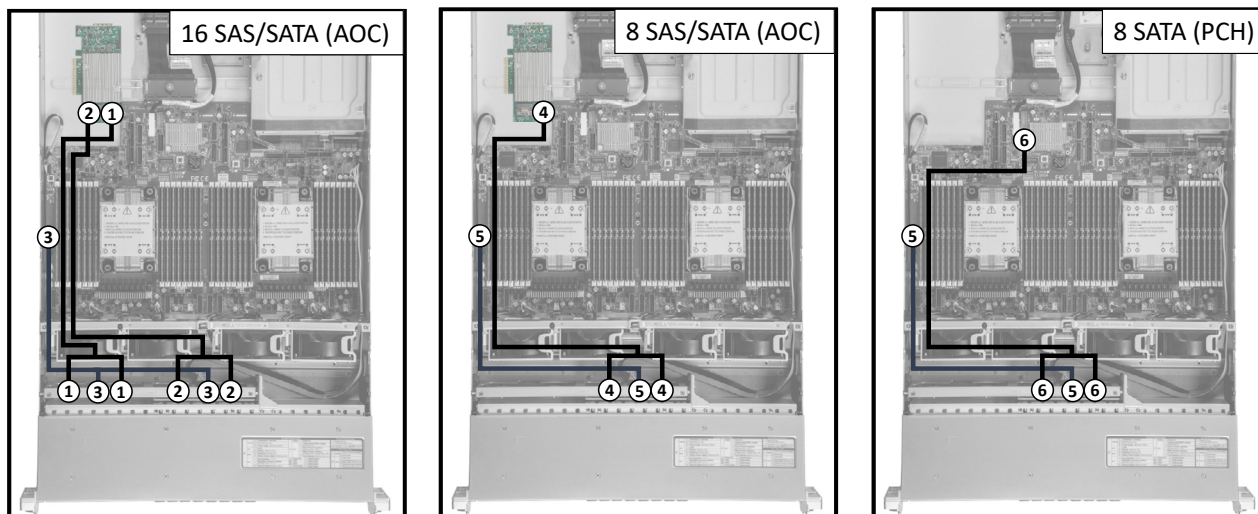
## SYS-221H-TN24R Storage Cables - NVMe



SYS-221H-TN24R Storage Cables - NVMe			
Cable	Cable Part Number	Connection From	Connection To
1*	CBL-MCIO-1245AM5FLE	Motherboard, JPCIE2A1	Front Backplane, NVMe0 NVMe1
2	CBL-MCIO-1250AM5FLE	Motherboard, JPCIE2B1	Front Backplane, NVMe2 NVMe3
3	CBL-MCIO-1221M5	Motherboard, P1_NVME1	Front Backplane, NVMe4 NVMe5
4	CBL-MCIO-1222M5LF	Motherboard, P1_NVME2	Front Backplane, NVMe6 NVMe7
5	CBL-MCIO-1221M5	Motherboard, P1_NVME3	Front Backplane, NVMe8 NVMe9
6	CBL-MCIO-1245M5-M	Motherboard, JPCIE1A1	Front Backplane, NVMe10 NVMe11
7	CBL-MCIO-1245M5-M	Motherboard, JPCIE1B1	Front Backplane, NVMe12 NVMe13
8	CBL-MCIO-1237M5-M	Motherboard, JPCIE3A1	Front Backplane, NVMe14 NVMe15
9	CBL-MCIO-1245M5-M	Motherboard, JPCIE3B1	Front Backplane, NVMe16 NVMe17
10	CBL-MCIO-1227M5	Motherboard, P2_NVME1	Front Backplane, NVMe18 NVMe19
11	CBL-MCIO-1218AM5REF	Motherboard, P2_NVME2	Front Backplane, NVMe20 NVMe21
12	CBL-MCIO-1217M5	Motherboard, P2_NVME3	Front Backplane, NVMe22 NVMe23
13*	CBL-MCIO-1217M5	Motherboard, P1_NVME1	Front Backplane, NVMe0 NVMe1
14*	CBL-MCIO-1217M5	Motherboard, JPCIE5A1	Rear Backplane 1, CN2000
15*	CBL-MCIO-1224M5	Motherboard, JPCIE5B1	Rear Backplane 2, CN2000

\*This cable connection provides a NVMe SMBus and/or NVMe VPP bus communication links between the system and the storage backplane. NVMe devices attached to the storage backplane may have detection or hot-swap issues if this cable not connected properly.

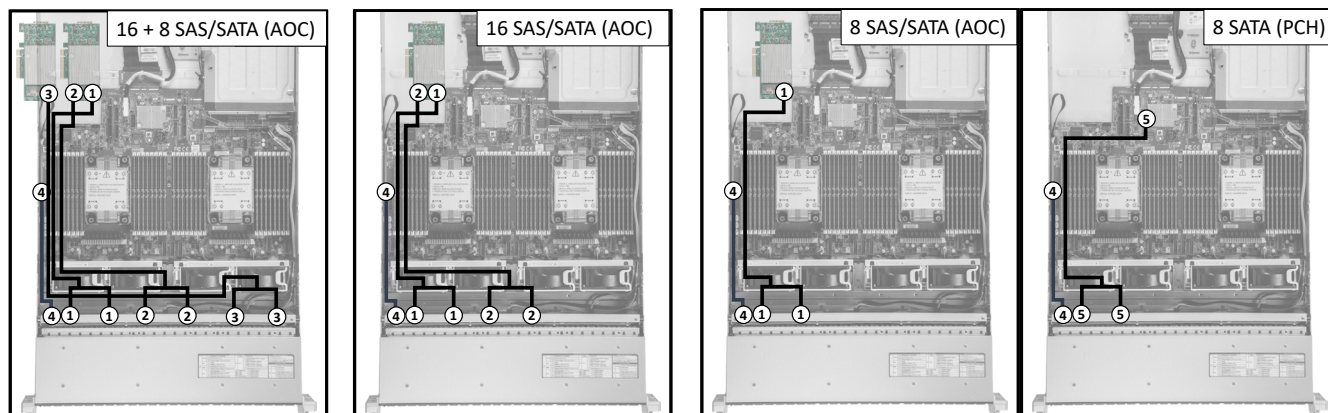
## SYS-221H-TNR Storage Cables - SAS/SATA



### SYS-221H-TNR Storage Cables - SAS/SATA

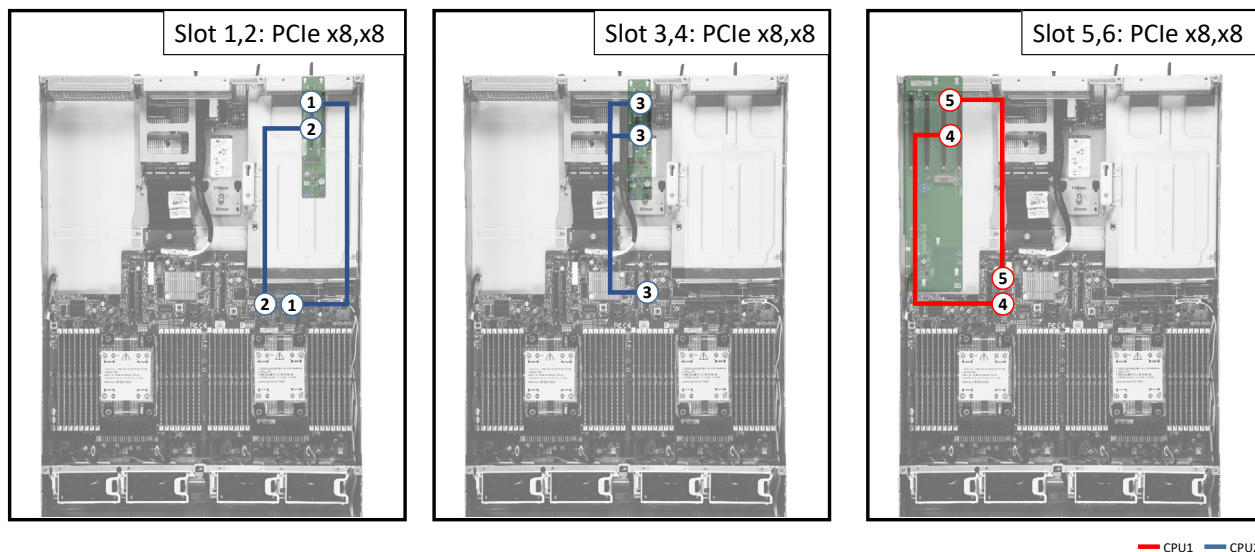
Cable	Cable Part Number	Connection From	Connection To
1	CBL-SAST-1276F-100	Storage AOC, CN0	Front Backplane (optional), CN1 & CN2
2	CBL-SAST-1276F-100	Storage AOC, CN1	Front Backplane (primary), CN1 & CN2
3	CBL-CDAT-1062Y-45	Motherboard, JNVI2C1	Front Backplanes (optional & primary), JIPMB1
4	CBL-SAST-1276F-100	Storage AOC, CN0	Front Backplane (primary), CN1 & CN2
5	CBL-CDAT-1062	Motherboard, JNVI2C1	Front Backplane (primary), JIPMB1
6	CBL-SAST-1258LP-100	Motherboard, I-SATA 0-7	Front Backplane (primary), CN1 & CN2

## SYS-221H-TN24R Storage Cables - SAS/SATA



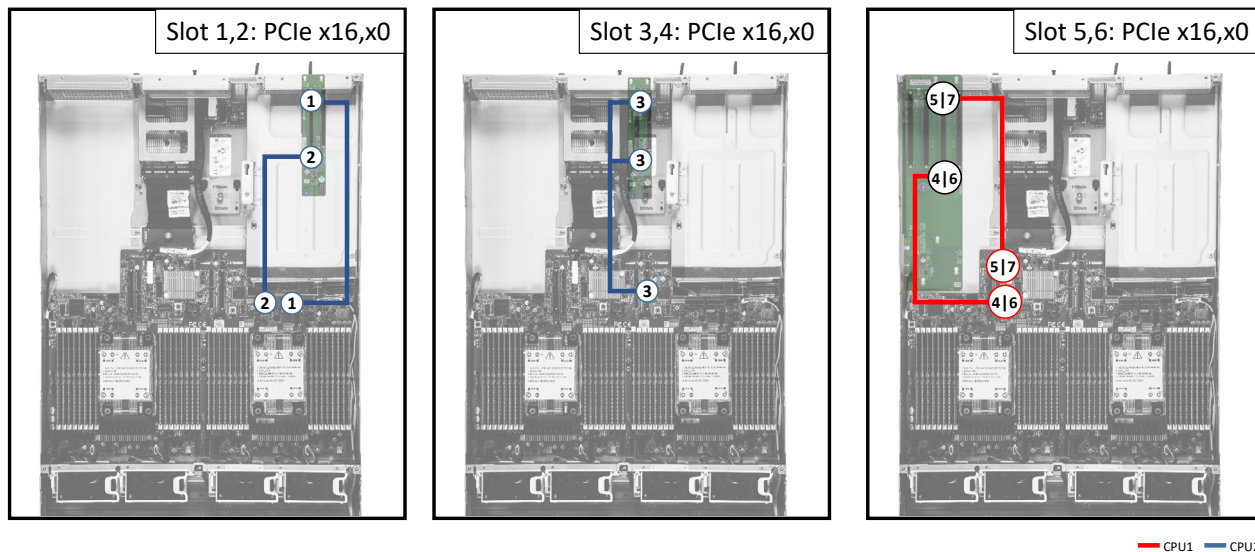
SYS-221H-TN24R Storage Cables - SAS/SATA			
Cable	Cable Part Number	Connection From	Connection To
1	CBL-SAST-1264F-100	Storage AOC, CN0	Backplane, SAS 0-3 & SAS 4-7
2	CBL-SAST-1276F-100	Storage AOC, CN1	Backplane, SAS 8-11 & SAS 12-15
3	CBL-SAST-1296F-100	Storage AOC, CN0	Backplane, SAS 16-19 & SAS 20-23
4	CBL-CDAT-1062	Motherboard, JNV12C1	Backplane, BMC I2C
5	CBL-SAST-1258LP-100	Motherboard, I-SATA 0-7	Backplane, SAS 0-3 & SAS 4-7

## PCIe Cables - Expansion Card Slots



PCIe Cables - Expansion Card Slots			
Cable	Cable Part Number	Connection From	Connection To
1	CBL-MCIO-1233M5R	Motherboard, JPCIE5A1	Riser Card, JPCIE1A1
2	CBL-MCIO-1232M5	Motherboard, JPCIE5B1	Riser Card, JPCIE2A1
3	CBL-GNZ4-1227M5YR21	Motherboard, JPCIE4	Riser Card, JPCIE1A1 & JPCIE2A1
4	CBL-MCIO-1222AM5	Motherboard, JPCIE2A1	Riser Card, JPCIE2A1
5	CBL-MCIO-1222AM5	Motherboard, JPCIE2B1	Riser Card, JPCIE1A1

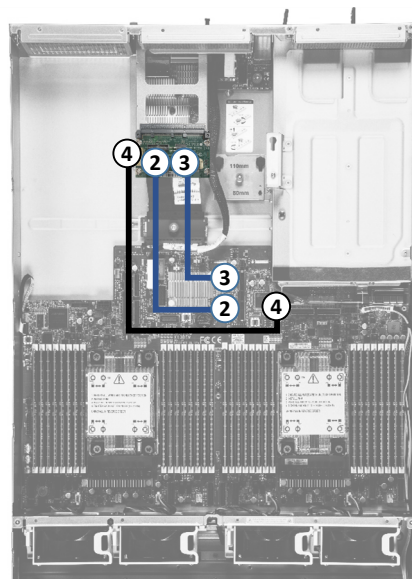
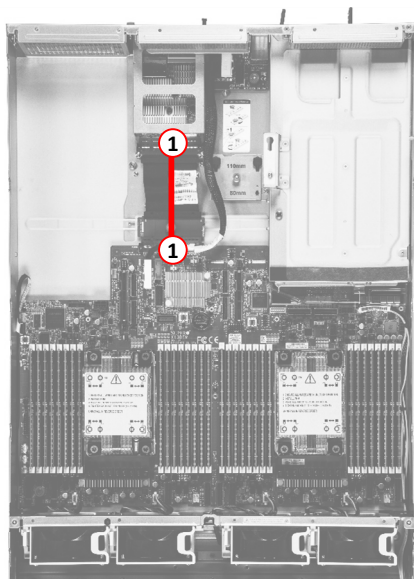
## PCIe Cables - Expansion Card Slots



PCIe Cables - Expansion Card Slots			
Cable	Cable Part Number	Connection From	Connection To
1	CBL-MCIO-1233M5R	Motherboard, JPCIE5A1	Riser Card, JPCIE1A1
2	CBL-MCIO-1233M5R	Motherboard, JPCIE5B1	Riser Card, JPCIE1B1
3	CBL-GNZ4-1227M5YRR16	Motherboard, JPCIE4	Riser Card, JPCIE1A1 & JPCIE1B1
4	CBL-MCIO-1222AM5	Motherboard, JPCIE2A1	Riser Card (RSC-H2-6888G5L), JPCIE2A1
5	CBL-MCIO-1226AM5	Motherboard, JPCIE2B1	Riser Card (RSC-H2-6888G5L), JPCIE2B1
6	CBL-MCIO-1226AM5R	Motherboard, JPCIE2A1	Riser Card (RSC-H-68G5), JPCIE1A1
7	CBL-MCIO-1226AM5R	Motherboard, JPCIE2B1	Riser Card (RSC-H-68G5), JPCIE1B1



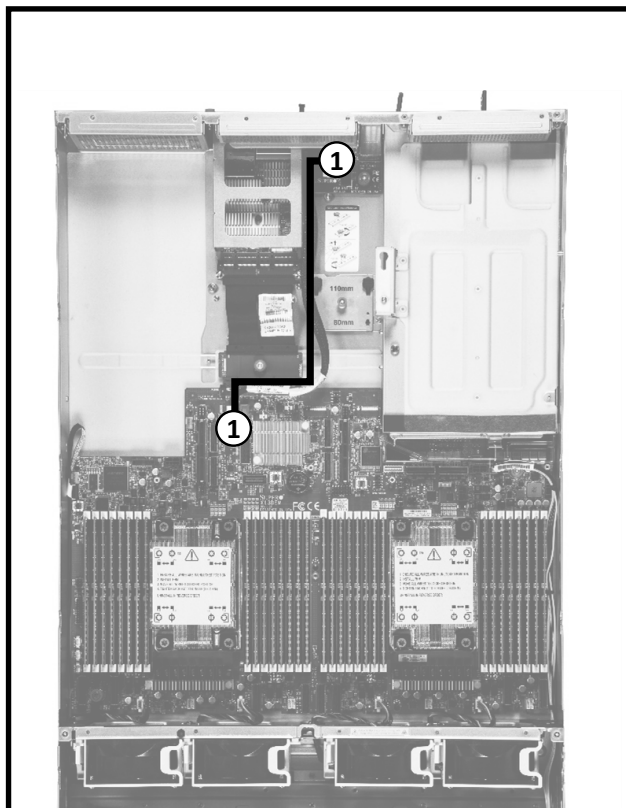
## PCIe Cables - AIOM/OCP 3.0 NIC Slots



— CPU1 — CPU2

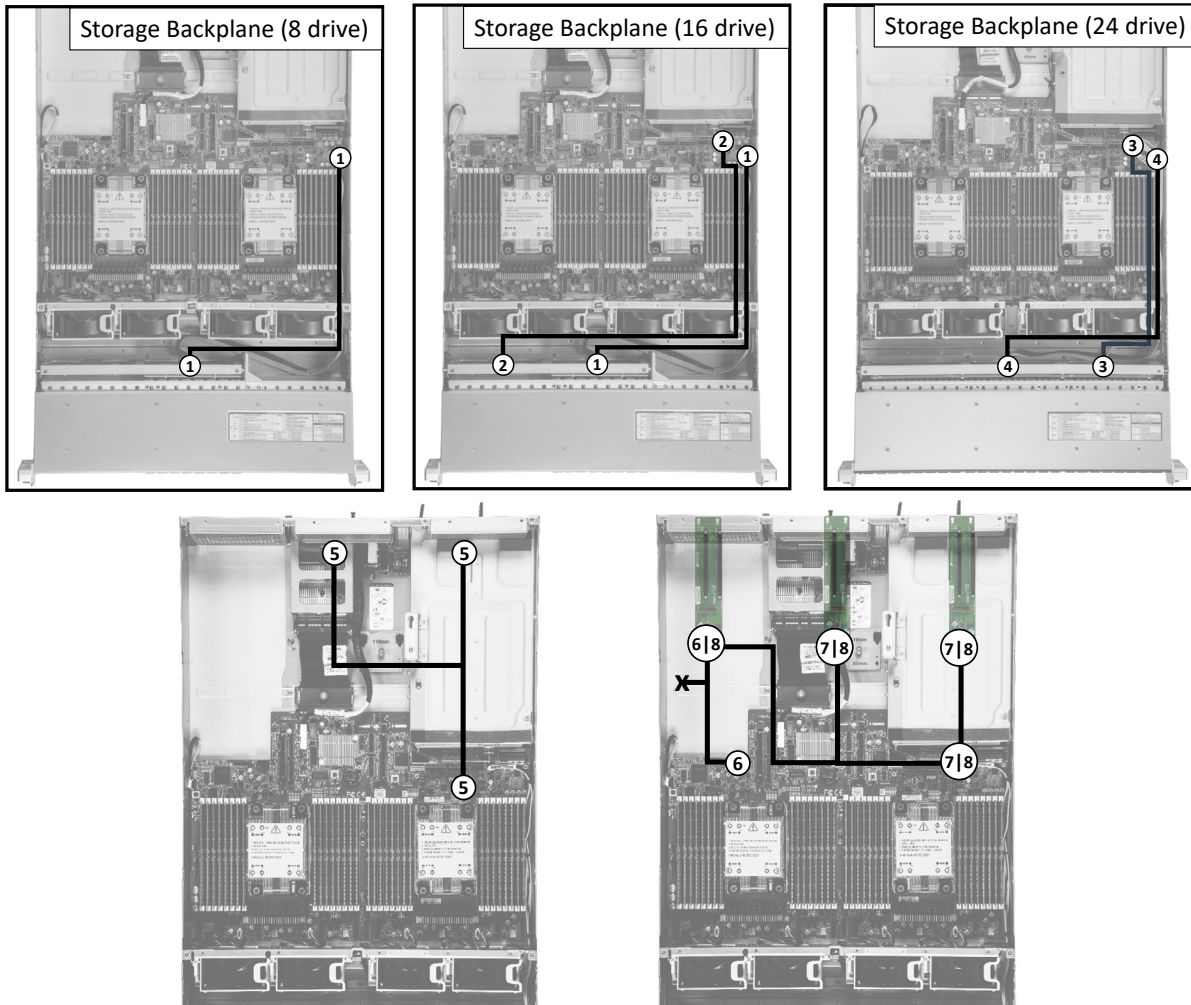
PCIe Cables - AIOM/OCP 3.0 NIC Slots			
Cable	Cable Part Number	Connection From	Connection To
1	CBL-GNZ5-1307	Motherboard, JAIOM1	AIOM/OCP 3.0 NIC
2	CBL-MCIO-1221M5	Motherboard, JPCIE3A1	AIOM Board, JPCIE1A1
3	CBL-MCIO-1218M5-1	Motherboard, JPCIE3B1	AIOM Board, JPCIE1B1
4	CBL-CDAT-1060-30	Motherboard, JAIOM2SB1	AIOM Board, JAIOMSB1

## I/O Board Cable



I/O Board Cable			
Cable	Cable Part Number	Connection From	Connection To
1	CBL-SAST-1225LP	Motherboard, JIO1	I/O Board, JIO1

## Power Cables



Power Cables			
Cable	Cable Part Number	Connection From	Connection To
1	CBL-PWEX-1142-60	Motherboard, JPMW1	Backplane, JPWR1
2	CBL-PWEX-1142B-70	Motherboard, JPMW5	Backplane, JPWR1
3	CBL-PWEX-1142-40	Motherboard, JPMW5	Backplane, JPWR2
4	CBL-PWEX-1142-60	Motherboard, JPMW1	Backplane, JPWR1
5	CBL-PWEX-1136YB-25	Motherboard, JPMW3	Backplane, JPWR1
6	CBL-PWEX-1136YB-25	Motherboard, JPMW4	Riser Card (Slot 5-6, RSC-H-68G5), JPWR1
7	CBL-PWEX-1136YB-25	Motherboard, JPMW2	Riser Card (Slot 1-2), JPWR1 & Riser Card (Slot 3-4), JPWR1
8	CBL-PWEX-1136YVB-42	Motherboard, JPMW2	Riser Card (Slot 1-2), JPWR1 & Riser Card (Slot 3-4), JPWR1 & Riser Card (Slot 5-6, RSC-H-68G5), JPWR1

\*The riser card power cable(s) installed in the system may vary depending on the optional riser cards or GPUs installed in the system.

## 3.12 Power Supply

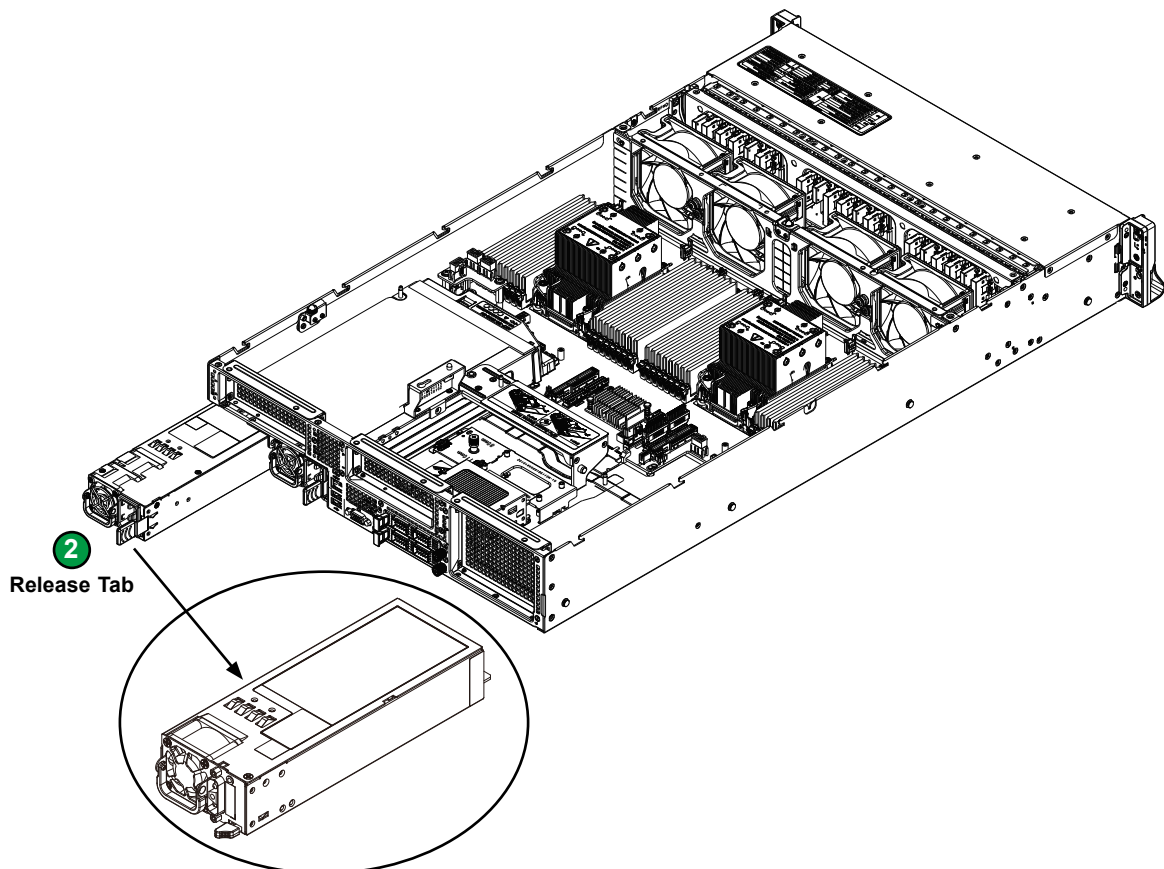
The system includes two hot-plug power supply modules. These modules will automatically sense and operate at an input voltage between 100V to 240V. Note that different input voltages will result in different maximum power output levels.

In the event of a power module failure, the other power module will continue to power the system on its own. Failed power supply modules can be replaced without powering down the system. Replacement modules can be ordered directly from Supermicro.

An amber light on the power supply is illuminated when the power is switched off. A green light indicates that the power supply is operating.

### ***Replacing the Power Supply***

1. Unplug the AC power cord from the failed power supply module.
2. Push and hold the release tab on the back of the power supply.
3. Grasp the handle of the power supply and pull it out of its bay.
4. Push the new power supply module into the power bay until it clicks into the locked position.
5. Plug the AC power cord back into the power supply module.



**Figure 3-13. Installing a Power Supply Module**

## Chapter 4

# Motherboard Connections

This section describes the jumpers, connections, and LEDs on the motherboard and provides pinout definitions. Note that depending on how the system is configured, not all connections are required. The LEDs on the motherboard are also described here. A motherboard layout indicating component locations may be found in [Chapter 1](#). More detail can be found in the [Motherboard Manual](#). Please review the Safety Precautions in [Appendix A](#) before installing or removing components.

### 4.1 Power Connections

#### Power Supply Connectors

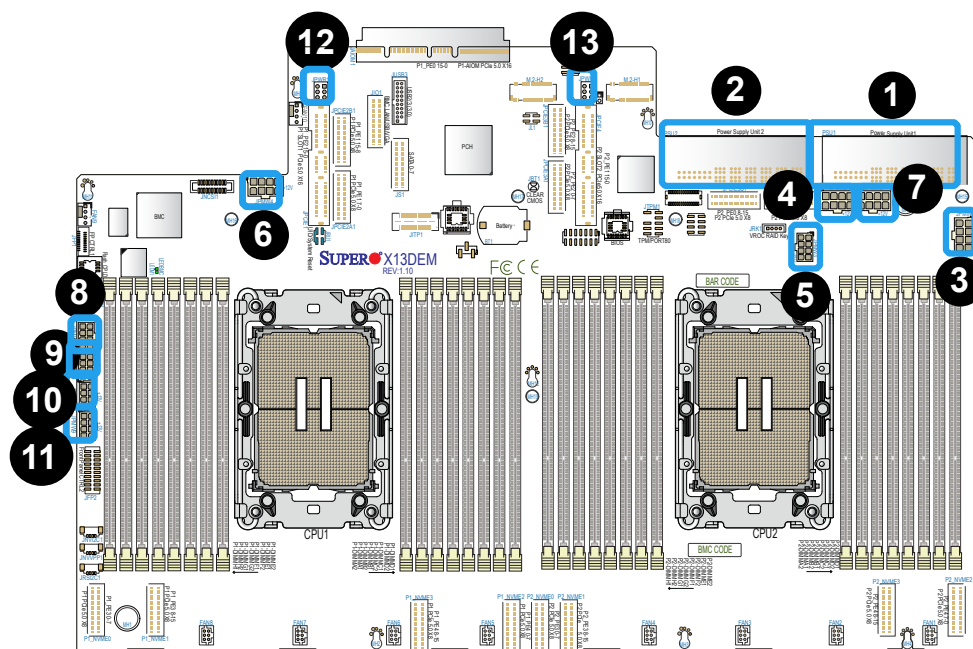
Two power supply connectors, located at PSU1/PSU2, provide main power to your system, and nine 8-pin power connectors (JPMW1~ JPMW9) are used for +12 V devices. Another two 6-pin power connectors (JPWR1 and JPWR4) provide additional power for system use. All these power connectors meet the ATX SSI EPS 12V specification.

12V 8-pin Power Pin Definitions	
Pin#	Definition
1 - 4	Ground
5 - 8	+12 V

**Note:** Refer to the table below for the power supplies that support the main power supply units (PS1/PS2) in the Supermicro hyper servers. For detailed power supply support for your particular server, please refer to your hyper server user manual.

PWS-2K08F-1R (AC 2000W)	PWS-1K31D-1R (DC 1300W)	PWS-1K24A-1R (AC 1200W)
PWS-1K63A-1R (AC 1600W)	PWS-2K07A-1R (AC 2000W)	PWS-2K63A-1R (AC 2600W)
PWS-1K31D-1R (DC 1300W)	PWS-2K07A-1R (AC 2000W)	

**Important:** To provide adequate power to your system, be sure to connect the main power supplies (PSU1/PSU2) to the power supply. Failure to do so may void the manufacturer warranty on your power supply and motherboard.



1. PSU1: Main PWR Supply Unit 1
2. PSU2: Main PWR Supply Unit 2
3. JPMW1: 8-pin +12V PWR Connector 1
4. JPMW2: 8-pin +12V PWR Connector 2
5. JPMW3: 8-pin +12V PWR Connector 3
6. JPMW4: 8-pin +12V PWR Connector 4
7. JPMW5: 8-pin +12V PWR Connector 5
8. JPMW6: 8-pin +12V PWR Connector 6
9. JPMW7: 8-pin +12V PWR Connector 7
10. JPMW8: 8-pin +12V PWR Connector 8
11. JPMW9: 8-pin +12V PWR Connector 9
12. JPWR1: 6-pin PWR Connector 1
13. JPWR4: 6-pin PWR Connector 2

## 4.2 Headers and Connectors

### Fan Headers

There are eight 6-pin fan headers (FAN1-FAN8) and two 4-pin fan headers (FAN9/FAN10) on the motherboard. These fan headers are used for the cooling fans for your system. Fan speed control for these fans is supported by Thermal Management via the BMC 2.0 interface. Refer to the motherboard layout in Chapter 1 for the locations of the fan headers.

### TPM/Port 80 Header

The JTPM1 header is used to connect a Trusted Platform Module (TPM)/Port 80, which is available from Supermicro (optional). A TPM/Port 80 connector is a security device that supports encryption and authentication in hard drives. It allows the motherboard to deny access if the TPM associated with the hard drive is not installed in the system. Refer to the motherboard layout in Chapter 1 for the location of the TPM header. Please go to the following link for more information on the TPM: <http://www.supermicro.com/manuals/other/TPM.pdf>.

Trusted Platform Module Header Pin Definitions			
Pin#	Definition	Pin#	Definition
1	+3.3 V	2	SPI_CS#
3	RESET#	4	SPI_MISO
5	SPI_CLK	6	GND
7	SPI_MOSI	8	NC
9	+3.3 V Stdby	10	SPI_IRQ#

### 6-pin BMC External I2C Header

A System Management Bus header for the BMC is located at JIPMB1. Connect the appropriate cable here to use the IPMB I<sup>2</sup>C connection on your system. Refer to the motherboard layout in Chapter 1 for the location of JIPMB1.

### NC-SI Connector

The NC-SI (Network Controller Sideband Interface) connector is located at (JNCSI1). This connector is used to connect a Network Interface Card (NIC) to the motherboard to allow the onboard BMC (Baseboard Controller) to communicate with a network.

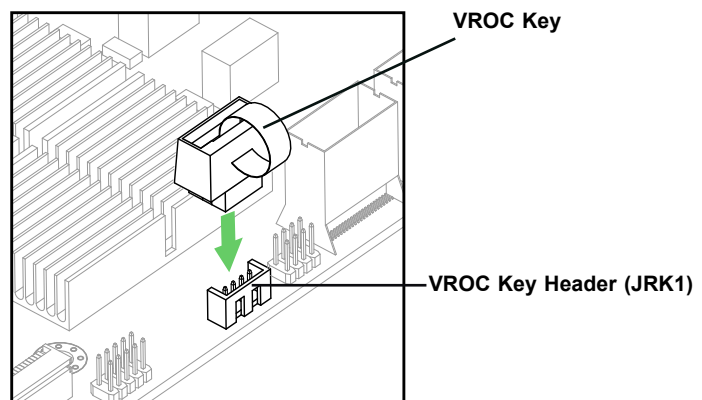
**Note:** For detailed instructions on how to configure Network Interface Card (NIC) settings, please refer to the Network Interface Card Configuration User's Guide posted on the web page under the link: <http://www.supermicro.com/support/manuals/>.

### VROC RAID Key Header

A VROC RAID Key header is located at JRK1 on the motherboard. Install a VROC RAID key on JRK1 for NVMe RAID support as shown in the illustration below. Refer to the motherboard layout in Chapter 1 for the location of JRK1.

**Note:** For detailed instructions on how to configure VROC RAID settings, please refer to the VROC RAID Configuration User's Guide posted on the web page under the link: <http://www.supermicro.com/support/manuals/>.

Intel VROC Key Pin Definitions	
Pin#	Definition
1	Ground
2	3.3 V Standby
3	Ground
4	PCH RAID Key



**Note:** The graphics contained in this user's manual are for illustration only. The components installed in your system may or may not look exactly the same as the graphics shown in the manual.



### NVMe SMBus Headers

NVMe SMBus (I<sup>2</sup>C) header (JNVI2C1), used for PCIe SMBus clock and data connections, provides hot-plug support via a dedicated SMBus interface. This feature is only available for a Supermicro complete system with an Supermicro proprietary NVMe add-on card and a proper cable installed. See the table below for pin definitions.

NVMe SMBus Header Pin Definitions	
Pin#	Definition
1	Data
2	Ground
3	Clock
4	VCCIO

### NVMe VPP Bus Connector

A NVMe VPP Bus connector is located at JNVVPP1 on the motherboard. The NVMe VPP connector provides hot plug support for the NVMe devices, which will allow the user to replace NVMe devices without shutting down and powering off the system. Refer to the motherboard layout in Chapter 1 for the location of JNVVPP1.

### Chassis Intrusion

A Chassis Intrusion header is located at JL1 on the motherboard. Attach the appropriate cable from the chassis to inform you when the chassis is opened. Refer to the table below for pin definitions.

Chassis Intrusion Pin Definitions	
Pin#	Definition
1	Intrusion Input
2	Ground

### PCIe I<sup>2</sup>C Header

A PCIe I<sup>2</sup>C (SMBus) header is located at JRSI<sup>2</sup>C1 on the motherboard. The PCIe SMBus connector is used for PCIe cards to allow the BMC or the BIOS to read disk drive information or FRUs more effectively. Refer to the motherboard layout in Chapter 1 for the location of JRSI<sup>2</sup>C1.

**PCIe 3.0 M.2-H1/M.2-H2 Slots**

Two PCIe 3.0/SATA3 Hybrid M.2 slots are located at M.2-H1 and M.2-H2 on the motherboard. These M.2/SATA3 Hybrid slots support M.2 NVMe/SATA3 SSDs in the 2280 and 22110 form factors. To accommodate the 2280 and 22110 form factors, two M.2 mounting holes (MH17/MH18) are provided on the motherboard. Use Mounting Hole MH17 for M.2-H2 slot support, and MH18 for M.2-H1 slot support. M.2 allows for a variety of card sizes, increased functionality, and spatial efficiency. Refer to the motherboard layout in Chapter 1 for the locations of the M.2/SATA3 Hybrid slots and the mounting holes.

**MCIO NVMe Connectors**

MCIO NVMe connectors, located at P1\_NVME 0~3 and P2\_NVME 0~3, provide eight PCIe 5.0 x8 connections on the motherboard. P1\_NVME 0~3 connections are supported by CPU1, and P2\_NVME 0~3 connections supported by CPU2. Use these MCIO connectors to support high-speed PCIe storage devices.

**Note:** When installing an NVMe device on a motherboard, please be sure to connect the first NVMe port (P1\_NVME0) first for your system to work properly.

**SATA 3.0 0~7 Ports**

A SATA 3.0 header, located at JS1, supports eight SATA 3.0 connections (SATA0~7) on the motherboard. These SATA 3.0 ports are supported by the Intel chipset. Connect a proper SATA cable to JS1 to use SATA 3.0 connections.

**Low-profile (LP) Slim SAS I/O Connector**

A low-profile slim SAS I/O connector, located on JIO1, provides dedicated BMC LAN/USB/VGA support on the rear side of the motherboard. Refer to the motherboard layout in Chapter 1 for the location of JIO1.

## Control Panel

### Front Control Panel Header with I<sup>2</sup>C

There are two front control panel headers located on this motherboard. Front control panel header 1, located at JFP1, contains header pins for various buttons and LED indicators with I<sup>2</sup>C support for front access. These front control panel headers are designed specifically for use with Supermicro chassis. See the figure below for the pin-out descriptions for JFP1.

JFP1	
1	Power Button
2	Reset/UID Button
3	UID LED_N
4	Fail LED_N (OH/FF/PF)
5	LAN-2 Activity LED
6	LAN-1 Activity LED (Aggregate all LAN)
7	HDD Activity LED
8	Standby LED_N
9	Power/RoT LED_N
10	P3V3_STBY
11	Ground
12	I2C Data
13	I2C Clock
14	Ground
15	Power Fail LED_P
16	P5V_USB
17	P5V_USB
18	P5V_USB
19	Power Fail LED_N
20	Ground

Figure 4-1. JFP1 Header Pins

### Power On and BMC/BIOS Status LED Button

The Power On and BMC/BIOS Status LED button is located on pin 1 of the front control panel header located at JFP1. Momentarily contacting pin 1 of JFP1 will power on/off the system or display BMC/BIOS status. Refer to the table below for more information.

Power Button BMC/BIOS Status LED Indicator	
Status	Event
Green: solid on	System power on
BMC/BIOS blinking green at 4 Hz	BMC/BIOS checking
BIOS blinking gree at 4 Hz	BIOS recovery/update in progress
BMC blinking red x2 (2 blinks red) at 4 Hz, 1 pause at 2 Hz (on-on-off-off)	BMC recovery/update in progress
BMC/BIOS blinking green at 1 Hz	Flash not detected or golden image checking failure

### System Reset Button/Front UID Switch

The System Reset button/Front UID switch connection is located on pin 2 of JFP1, which is used in conjunction with the Reset button/UID switch select jumper located at JRU1. To configure pin 2 of JFP1 for front UID switch use in a chassis that supports front UID connection, close pins 1 and 2 of jumper JRU1. To set pin 2 of JFP1 for System Reset, close pin 3 and pin 4 of jumper JRU1. Refer to the jumper section for more information on JRU1. Refer to the motherboard layout in Chapter 1 for the location of JRU1.

Front UID Switch/Reset Button Select Jumper (JRU1) Jumper Settings	
State	Description
Close pins 1 and 2 of JRU1	Pin 2 of JFP1: used for front UID switch support
Close pins 3 and 4 of JRU1	Pin 2 of JFP1: used for System Reset support

### UID LED

The unit identifier LED connection is located on pin 3 of JFP1. Refer to the motherboard layout in Chapter 1 for more information on JFP1.

### Fail LED (Information LED for OH/FF/PF)

The Fail LED (Information LED for OH/Fan Fail/PWR Fail) connection is located on pin 4 of JFP1. The LED provides warnings of overheating, power failure, or fan failure. Refer to the motherboard layout in Chapter 1 for more information.

Fail LED (Information LED) (OH/Fan Fail/PWR Fail) LED States	
Status	Description
Solid red (on)	An overheat condition has occurred.
Blinking red (1 Hz)	Fan failure: check for an inoperative fan.
Blinking red (0.25 Hz)	Power failure: check for a non-operational power supply
Blinking red (10 Hz) (FP red LED)	CPLD recovery mode error(s)
Solid blue	UID has been activated locally. Use this function to locate a unit in a rack mount environment that might be in need of service.
Blinking blue (1 Hz)	Local UID has been activated locally on. Use this function to identify a unit that might be in need of service.
BIOS/BMC blinking blue (10 Hz)	BIOS/BMC: recovery and/or update in progress
Red Info LED blinking (10 Hz) and MB UID LED blue blinking (10 Hz)	CPLD: recovery and/or update in progress

### LAN1/LAN2 (NIC1/NIC2)

The NIC (Network Interface Controller) LED connection for LAN Port 1 is located on pin 6 of JFP1, and LAN Port 2 is on pin 5. Refer to the table below.

LAN1/LAN2 LED LED States	
Color	State
NIC 2: Blinking green	LAN 2: Active
NIC 1: Blinking green	LAN 1: Active

### HDD Activity LED

The HDD activity LED connection is located on pin 7 of JFP1. When this LED is blinking green, it indicates HDD activity. Refer to the table below.

HDD LED LED State	
Color	State
Blinking Green	HDD Active

### Standby Power LED

The LED indicator for standby power is located on pin 8 of JFP1. If this LED is on, standby power is on.

### RoT (Root of Trust) Power LED

The Power LED for RoT (Root of Trust) connection is located on pin 9 of JFP1. If this LED is on, power for the RoT chip is on.

### Standby Power

A Standby Power (I<sup>2</sup>C) connection is located on pin 10 ~ pin 14 of JFP1 to provide power to the system when it is in standby mode. Refer to the table below for pin definitions.

3.3V Standby PWR Pin Definitions	
Pin#	Definition
10	P3V3 Standby
11	Ground
12	I <sup>2</sup> C Data
13	I <sup>2</sup> C Clock
14	Ground

### Power Fail LED Indicators

Power Failure LED Indicators are located on pins 15 and 19 of JFP1. Refer to the table below for pin definitions.

FP Power LED Pin Definitions (JFP1)	
Pin#	Definition
15	PWR Failure LED-Positive
19	PWR Failure LED-Negative

### FP USB Power

Front Panel USB power connections are located on pin 16 ~ pin 18 of JFP1 to provide power to for front USB devices. Refer to the table below for pin definitions.

FP USB PWR Pin Definitions	
Pin#	Definition
16	
17	+5 V USB PWR
18	

### Front Control Panel Header 2

In addition to Front Control Panel header 1 (JFP1), Front Control Panel header 2 (JFP2), also located on the front side of the chassis, provides additional functions, including USB and VGA support to the system. Refer to the motherboard layout in Chapter 1 for the location of JFP2.

## 4.3 Input/Output Ports

### **BMC\_LAN/USB/VGA/COM Slot (JIO1)**

The low-profile slimSAS I/O connector, located at JIO1, connects an I/O mezzanine board to the motherboard. This connector provides dedicated BMC LAN, VGA, and COM port header connections for rear side access. Refer to the layout below for the location of JIO1. Please also refer to the LED Indicator section for LAN LED information.

### **Advanced I/O Module (AIOM) for Rear I/O Support (JAIOM1)**

A Supermicro proprietary Advanced I/O Module (AIOM) connector used for a PCIe 5.0 x16 add-on module is located at JAIOM1. This AIOM connector (P1\_PE0 15-0), supported by CPU1, provides input/output connections on the rear side of your system. Refer to the motherboard layout in Chapter 1 for the location of JAIOM1.

### **AIOM Sideband Connector (JAIOM2SB1)**

An Supermicro proprietary Advanced I/O Module (AIOM) sideband connector is located at JAIOM1 on the motherboard. This AIOM slot provides support for AIOM sideband connections. Refer to the motherboard layout in Chapter 1 for the location of JAIOM2SB1.

### **VGA Connections**

There are two VGA connections in your system. The rear VGA connection is located on the BMCLAN/USB/VGA slot (JIO1) on the rear side of the motherboard. The front VGA header is located on the Front Panel Control Module (JFP2). These VGA connections provide analog interface support between the computer and the video displays. Refer to the motherboard layout in Chapter 1 for the locations of VGA connections.

### Universal Serial Bus (USB) 3.2 Header

A USB header that supports two USB 3.2 Gen1 ports (USB2/3) is located at JUSB3 on the rear side of the motherboard. These USB ports can be used for USB support via USB cables (not included). Refer to the motherboard layout in Chapter 1 for the location of JUSB3.

Trusted Platform Module Header Pin Definitions			
Pin#	Definition	Pin#	Definition
A1	VBUS	B1	Power
A2	D-	B2	USB_N
A3	D+	B3	USB_P
A4	GND	B4	GND
A5	Stda_SSRX-	B5	USB3_RN
A6	Stda_SSRX+	B6	USB3_RP
A7	GND	B7	GND
A8	Stda_SSTX-	B8	USB3_TN
A9	Stda_SSTX+	B9	USB3_TP



## CMOS Clear

JBT1 is used to clear CMOS, which will also clear passwords. Instead of pins, this jumper consists of contact pads to prevent accidentally clearing the contents of CMOS.

### To Clear CMOS



1. First power down the system and unplug the power cord(s).
2. Remove the cover of the chassis to access the motherboard.
3. Short the CMOS pads, JBT1, with a metal object such as a small screwdriver for at least four seconds.
4. Remove the screwdriver (or shorting device).
5. Replace the cover, reconnect the power cord(s), and power on the system.

**Note 1:** Clearing CMOS will also clear all passwords.

**Note 2:** Do not use the PW\_ON connector to clear CMOS.

## UID LED and System\_Reset Button Select Jumper

Jumper JRU1 is used in conjunction with pin 2 of Front Control Panel header 1 (JFP1) to function as a System\_Reset button or a UID LED button. To configure pin 2 of JFP1 for front UID button use in a chassis that supports front UID connection, close pins 1 and 2 of jumper JRU1. To set pin 2 of JFP1 for system reset support, close pins 3 and 4 of jumper JRU1. Refer to the table below for more information on JRU1. Also refer to the motherboard layout in Chapter 1 for the location of JRU1.

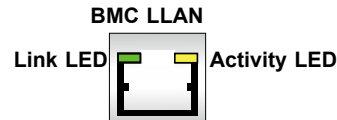
Front UID Switch/Reset Button Select Jumper (JRU1) Jumper Settings	
State	Description
Close Pin 1 and Pin 2 of JRU1	Pin 2 of JFP1: used for front UID switch support
Close Pin 3 and Pin 4 of JRU1	Pin 2 of JFP1: used for System Reset support

## 4.4 LED Indicators

### BMC LAN LEDs

A dedicated BMC LAN connection is provided on the low-profile Slim SAS I/O connector (JIO1) located on the rear side of the motherboard. The LED on the right indicates activity, and the LED on the left indicates the speed of the connection. Refer to the table below for more information.

BMC LAN LEDs		
	Color/State	Definition
Link (left)	Green: Solid Amber: Solid	100 Mbps 1Gbps
Activity (Right)	Amber: Blinking	Active



### Unit ID LED

The front UID LED indicator is located at LED1. This UID indicator provides easy identification of a system that may need services.

UID LED LED Indicator	
LED Color	Definition
Blue: On	System Identified

### Onboard Power LED

The Onboard Power LED is located at LEDPWR (LED2) on the motherboard. When this LED is on, the system power is on. Be sure to turn off the system power and unplug the power cords before removing or installing components. Refer to the table below for more information.

Onboard Power LED Indicator	
LED Color	Definition
Off	System Power Off (power cable not connected)
Green	System Power On

### BMC Heartbeat LED

A BMC Heartbeat LED is located at LEDBMC (LEDM1) on the motherboard. When LEDBMC is blinking green, the BMC is functioning normally. Refer to the motherboard layout in Chapter 1 for the location of LEDBMC.

BMC Heartbeat LED Indicator	
LED Color	Definition
Green: Blinking	BMC Normal

# Chapter 5

## Software

After the hardware has been installed, you can install the Operating System (OS), configure RAID settings, and install the drivers.

### 5.1 Microsoft Windows OS Installation

If you will be using RAID, you must configure RAID settings before installing the Windows OS and the RAID driver. Refer to the RAID Configuration User Guides posted on our website at [www.supernmicro.com/support/manuals](http://www.supernmicro.com/support/manuals).

#### *Installing the OS*

1. Create a method to access the Microsoft Windows installation ISO file. That might be a Media drive, perhaps using an external USB/SATA media drive, a USB flash drive, or the BMC KVM console.
2. Retrieve the proper drivers. Go to the Supermicro web page for your motherboard and click on "Download the Latest Drivers and Utilities", select the proper driver, and copy it to a USB flash drive.
3. Boot from a bootable device with Windows OS installation. You can see a bootable device list by pressing **F11** during the system bootup.

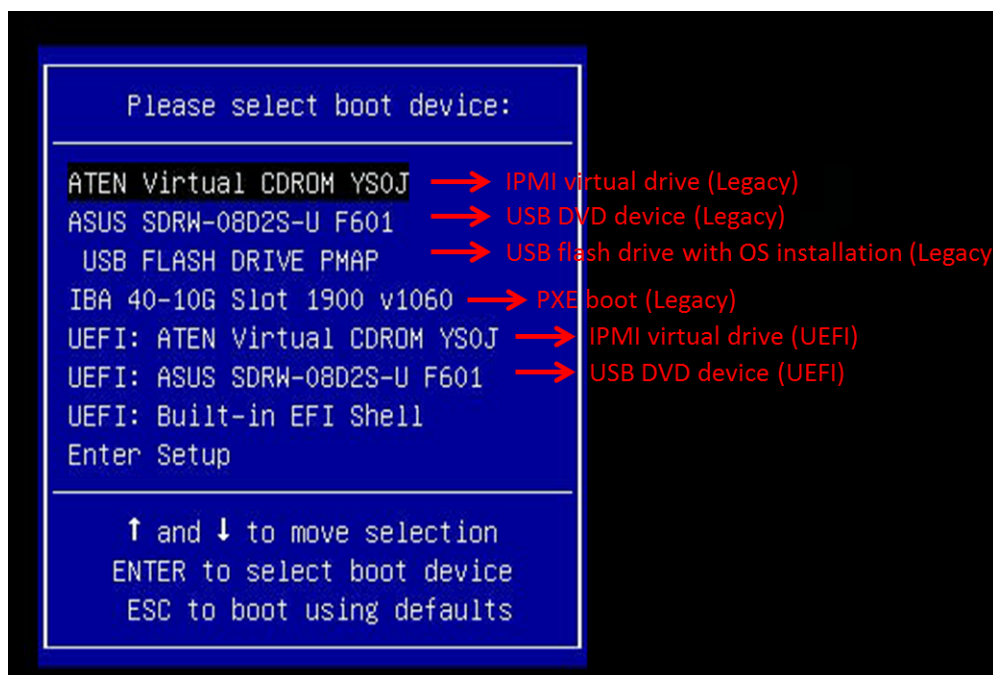
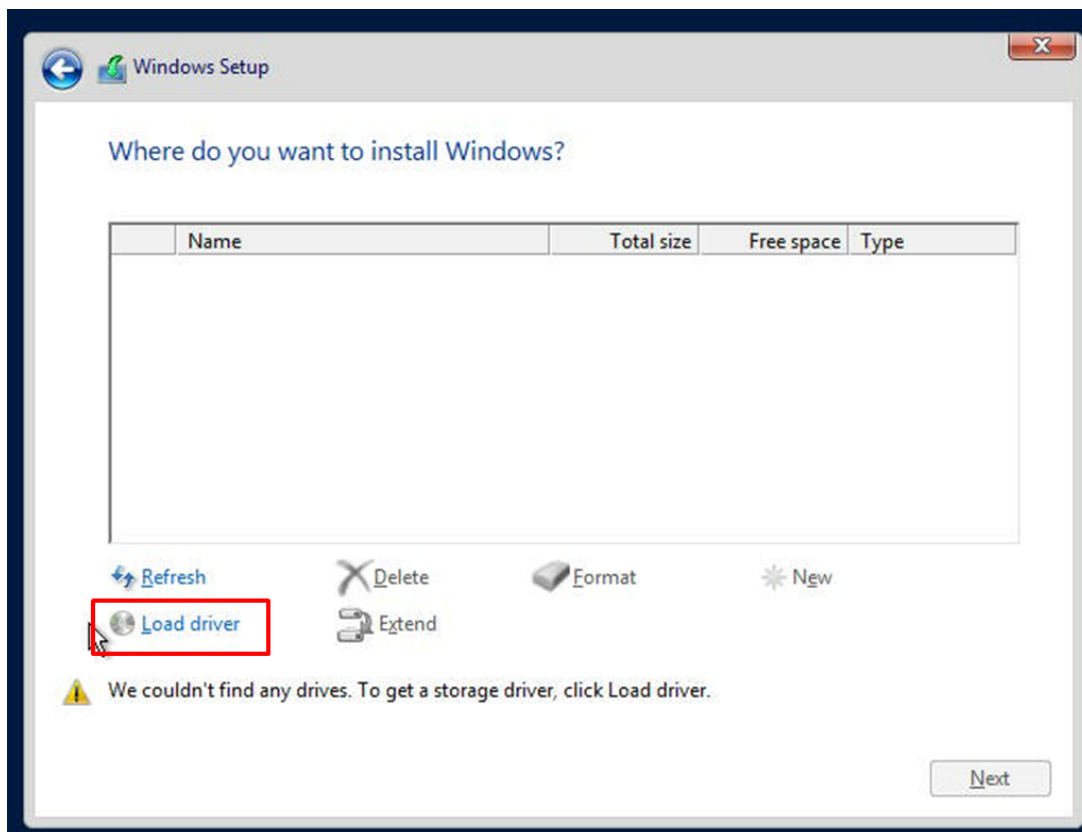


Figure 5-1. Select Boot Device

4. During Windows Setup, continue to the dialog box where you select the drives on which to install Windows. If the disk you want to use is not listed, click on “Load driver” link at the bottom left corner.



**Figure 5-2. Load Driver Link**

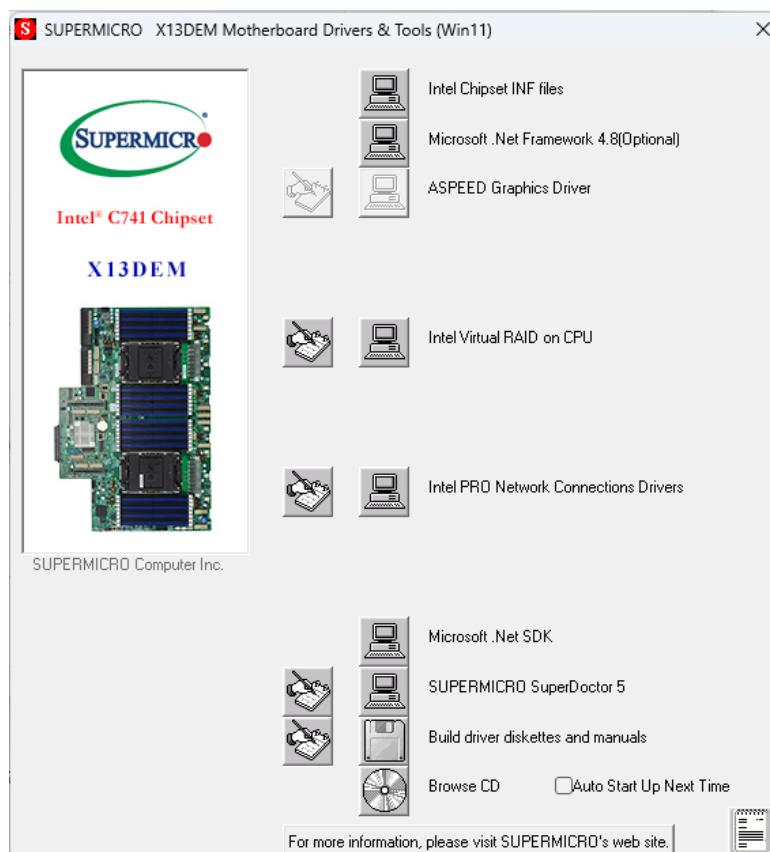
To load the driver, browse the USB flash drive for the proper driver files.

- Choose the SATA/sSATA AHCI driver indicated and then choose the storage drive on which you want to install it.
5. Once all devices are specified, continue with the installation.
  6. After the Windows OS installation has completed, the system will automatically reboot multiple times for system updates.

## 5.2 Driver Installation

The Supermicro website contains drivers and utilities for your system at <https://www.supermicro.com/wdl/driver>. Some of these must be installed, such as the chipset driver. After accessing the website, go into the CDR\_Images (in the parent directory of the above link) and locate the ISO file for your motherboard. Download this file to a USB flash or a media drive. (You may also use a utility to extract the ISO file if preferred.)

Another option is to go to the Supermicro website at <http://www.supermicro.com/products/>. Find the product page for your motherboard, and "Download the Latest Drivers and Utilities". Insert the flash drive or disk, and the screenshot shown below should appear.



**Figure 5-3. Driver and Tool Installation Screen**

**Note:** Click the icons showing handwriting on paper to view the readme files for each item. Click the computer icons to the right of these items to install each item (from top to the bottom) one at a time. **After installing each item, you must reboot the system before moving on to the next item on the list.** The bottom icon with a CD on it allows you to view the entire contents.

## 5.3 BMC

The X13DEM supports the Baseboard Management Controller (BMC). BMC is used to provide remote access, monitoring and management. There are several BIOS settings that are related to BMC.

For general documentation and information on BMC, please visit our website at:

<http://www.supermicro.com/products/nfo/BMC.cfm>.

## 5.4 Logging into the BMC (Baseboard Management Controller)

Supermicro ships standard products with a unique password for the BMC ADMIN user. This password can be found on a label on the motherboard.

When logging in to the BMC for the first time, please use the unique password provided by Supermicro to log in. You can change the unique password to a user name and password of your choice for subsequent logins.

For more information regarding BMC passwords, please visit our website at <http://www.supermicro.com/bmcpassword>.

# Chapter 6

## Optional Components

This chapter describes alternate configurations and optional system components.

Optional Parts
Storage Protocols
PCIe Options
Power Options
<a href="#">Cable Management Arm</a>
<a href="#">TPM Security Module</a>
Intel <a href="#">VROC</a> RAID Key

### 6.1 Storage Protocols Supported

The storage drive bays can be configured to support either SATA, SAS, or NVMe drives by adding optional parts to the system. See [Section 6.2](#) for the supported storage drive bay configurations and the optional parts required.

**SATA** – The system can support up to eight SATA drives from the onboard Intel PCH SATA controller. A SAS/SATA controller is needed for the 16 or 24 SATA drive configuration.

**SAS** – The system can support eight, 16, or 24 SAS drives with supported add-on storage controller card(s).

**NVMe** – The system can support eight, 16, or 24 NVMe drives.

## 6.2 Configuration Ordering Information

### Hyper 2U SYS-221H-TNR Drive Bay Configuration Options

#### Default



#### Option 1: 8 NVMe

Drive Bay #	Drive Type	Part Numbers
Drive Bays 0-7	NVMe (from CPU2)	CBL-MCIO-1252M5FLE CBL-MCIO-1219M5L CBL-MCIO-1234AM5LFRE CBL-MCIO-1234M5L

#### Option 2: 8 SAS/SATA

Drive Bay #	Drive Type	Part Numbers
Drive Bays 0-7	SAS/SATA	CBL-SAST-1276F-100 CBL-CDAT-1062  For Non RAID: AOC-S3808L-L8IT-O <sup>1</sup>  For Hardware RAID: AOC-S3908L-H8IR-16DD-O <sup>1</sup>

#### Option 3: 8 SATA

Drive Bay #	Drive Type	Part Numbers
Drive Bays 0-7	SATA	CBL-SAST-1258LP-100 CBL-CDAT-1062

#### Option 4: 16 NVMe

Drive Bay #	Drive Type	Part Numbers
Drive Bays 0-5	NVMe (from CPU1)	MCP-220-00196-0B (x8) BPN-NVME5-HS219N-S8
Drive Bays 6-15	NVMe (from CPU2)	CBL-MCIO-1252M5FLE (x2) CBL-MCIO-1219M5L (x2) CBL-MCIO-1234M5L (x2) CBL-MCIO-1229M5LFL CBL-MCIO-1234AM5LFRE CBL-PWEX-1142B-70



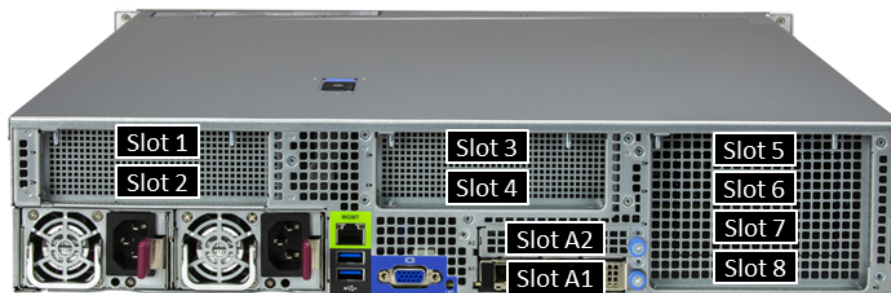
Option 5: 16 SAS/SATA		
Drive Bay #	Drive Type	Part Numbers
Drive Bays 0-15	SAS/SATA	MCP-220-00196-0B (x8) BPN-NVME5-HS219N-S8 CBL-SAST-1276F-100 (x2) CBL-PWEX-1142B-70 CBL-CDAT-1062Y-45  For Non-RAID: AOC-S3816L-L16IT-O <sup>1</sup>  For Hardware RAID: AOC-S3916L-H16IR-32DD-O <sup>1</sup>

Option 6: 8 NVMe + 8 SAS/SATA		
Drive Bay #	Drive Type	Part Numbers
Drive Bays 0-7	SAS/SATA	MCP-220-00196-0B (x8) BPN-NVME5-HS219N-S8
Drive Bays 8-15	NVMe (from CPU2)	CBL-MCIO-1252M5FLE CBL-MCIO-1219M5L CBL-MCIO-1234AM5LFRE CBL-MCIO-1234M5L CBL-SAST-1276F-100 CBL-PWEX-1142B-70 CBL-CDAT-1062  For Non-RAID: AOC-S3808L-L8IT-O <sup>1</sup>  For Hardware RAID: AOC-S3908L-H8IR-16DD-O <sup>1</sup>

Option 7: 8 NVMe + 8 SATA		
Drive Bay #	Drive Type	Part Numbers
Drive Bays 0-7	SATA	MCP-220-00196-0B (x8) BPN-NVME5-HS219N-S8
Drive Bays 8-15	NVMe (from CPU2)	CBL-MCIO-1252M5FLE CBL-MCIO-1219M5L CBL-MCIO-1234AM5LFRE CBL-MCIO-1234M5L CBL-SAST-1258LP-100 CBL-PWEX-1142B-70 CBL-CDAT-1062

<sup>1</sup>AOC needs to be installed in PCIe slot 8, so adding PCIe slot 5-8 with configuration option 1 or 2 is needed.

## Hyper 2U SYS-221H-TNR PCIe Slot Configuration Options



### Slots 1-2 Configuration Options

Default: No PCIe Slots		
Slot #	Slot Config	Part Numbers
Slot 1	Not Available	MCP-120-21101-0N (Included with system)
Slot 2	Not Available	

Option 1: 2 PCIe x8 Slots		
Slot #	Slot Config	Part Numbers
Slot 1	PCIe 5.0 x8 (CPU2)	MCP-240-21108-0N RSC-H-68G5
Slot 2	PCIe 5.0 x8 (CPU2)	CBL-MCIO-1233M5R CBL-MCIO-1232M5 CBL-PWEX-1136YB-25 <sup>1, 2</sup>

Option 2: 1 PCIe x16 Slot		
Slot #	Slot Config	Part Numbers
Slot 1	PCIe 5.0 x16 (CPU2)	MCP-240-21108-0N RSC-H-68G5
Slot 2	Not Available	CBL-MCIO-1233M5R (x2) CBL-PWEX-1136YB-25 <sup>1, 2</sup>

*Slots 3-4 Configuration Options*

<b>Default: No PCIe Slots</b>		
<b>Slot #</b>	<b>Slot Config</b>	<b>Part Numbers</b>
Slot 3	Not Available	MCP-120-21101-0N (Included with system)
Slot 4	Not Available	

<b>Option 1: 2 PCIe x8 Slots</b>		
<b>Slot #</b>	<b>Slot Config</b>	<b>Part Numbers</b>
Slot 3	PCIe 5.0 x8 (CPU2)	MCP-240-21108-0N MCP-120-82927-0N
Slot 4	PCIe 5.0 x8 (CPU2)	RSC-H-68G5 CBL-GNZ4-1227M5YR21 CBL-PWEX-1136YB-25 <sup>1, 2</sup>

<b>Option 2: 1 PCIe x16 Slot</b>		
<b>Slot #</b>	<b>Slot Config</b>	<b>Part Numbers</b>
Slot 3	PCIe 5.0 x16 (CPU2)	MCP-240-21108-0N MCP-120-82927-0N
Slot 4	Not Available	RSC-H-68G5 CBL-GNZ4-1227M5YRR16 CBL-PWEX-1136YB-25 <sup>1, 2</sup>

*Slots 5-8 Configuration Options*

Default: No PCIe Slots		
Slot #	Slot Config	Part Numbers
Slot 5	Not Available	MCP-120-21902-0N (Included with system)
Slot 6	Not Available	
Slot 7	Not Available	
Slot 8	Not Available	

Option 1: 4 PCIe x8 Slots		
Slot #	Slot Config	Part Numbers
Slot 5	PCIe 5.0 x8 (CPU1)	MCP-240-21908-0N RSC-H2-6888G5L CBL-MCIO-1222AM5 (x2)
Slot 6	PCIe 5.0 x8 (CPU1)	
Slot 7	PCIe 5.0 x8 (CPU1)	
Slot 8	PCIe 5.0 x8 (CPU1)	

Option 2: 1 PCIe x16 Slot & 2 PCIe x8 Slots		
Slot #	Slot Config	Part Numbers
Slot 5	PCIe 5.0 x16 (CPU1)	MCP-240-21908-0N RSC-H2-6888G5L CBL-MCIO-1222AM5 CBL-MCIO-1226AM5
Slot 6	Not Available	
Slot 7	PCIe 5.0 x8 (CPU1)	
Slot 8	PCIe 5.0 x8 (CPU1)	

Option 3: 1 PCIe x16 Slots		
Slot #	Slot Config	Part Numbers
Slot 5	PCIe 5.0 x16 (CPU1)	MCP-240-21908-0N RSC-H-68G5 RSC-H-6G5L CBL-MCIO-1226AM5R (x2) CBL-PWEX-1136YB-25 <sup>2</sup>
Slot 6	Not Available	
Slot 7	PCIe 5.0 x16 (CPU1)	
Slot 8	Not Available	

<sup>1</sup> If Slots 1-2 & Slots 3-4 are both enabled, then you only need one power cable CBL-PWEX-1136YB-25 to share between two RSC-H-68G5.

<sup>2</sup> If Slots 1 2 & Slots 3-4 & Slots 5-8 Option 3 are enabled, replace PWEX-1136YB-25 with one power cable CBL-PWEX-1136YVB-45 to share between three RSC-H-68G5.

Slot A1 (AIOM/OCP NIC Slot1) comes with the system.

Slot A2 (AIOM/OCP NIC Slot2) is optional and can only be used in non-NVMe drive bay configurations. To enable this slot, add MCP-120-82926-0N, CBL-CDAT-1060-30, CBL-MCIO-1218M5-1, CBL-MCIO-1221M5, AOM-AIOM-2X8-G5-P.

## Hyper 2U SYS-221H-TN24R Drive Bay Configuration Options



### Option 1: 24 NVMe

Drive Bay #	Drive Type	Part Numbers
Drive Bays 0-9	NVMe (from CPU1)	CBL-MCIO-1245AM5FLE CBL-MCIO-1250AM5FLE CBL-MCIO-1221M5 (x2) CBL-MCIO-1222M5LF
Drive Bays 10-23	NVMe (from CPU2)	CBL-MCIO-1245M5-M (x3) CBL-MCIO-1237M5-M CBL-MCIO-1227M5 CBL-MCIO-1218AM5REF CBL-MCIO-1217M5

### Option 2: 16 NVMe + 8 SAS/SATA

Drive Bay #	Drive Type	Part Numbers
Drive Bays 0-7	SAS/SATA	CBL-MCIO-1221M5 CBL-MCIO-1245M5-M (x3) CBL-MCIO-1237M5-M
Drive Bays 8-9	NVMe (from CPU1)	CBL-MCIO-1227M5 CBL-MCIO-1218AM5REF CBL-MCIO-1217M5 (x2) CBL-SAST-1264F-100
Drive Bays 10-23	NVMe (from CPU2)	For Non-RAID: AOC-S3808L-L8IT-O <sup>1</sup>  For Hardware RAID: AOC-S3908L-H8IR-16DD-O <sup>1</sup>

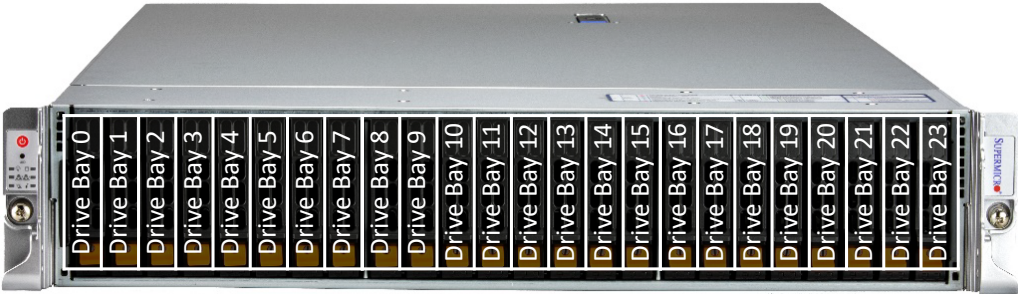
Option 3: 16 NVMe + 8 SATA		
Drive Bay #	Drive Type	Part Numbers
Drive Bays 0-7	SATA	CBL-MCIO-1221M5
Drive Bays 8-9	NVMe (from CPU1)	CBL-MCIO-1245M5-M (x3) CBL-MCIO-1237M5-M CBL-MCIO-1227M5
Drive Bays 10-23	NVMe (from CPU2)	CBL-MCIO-1218AM5REF CBL-MCIO-1217M5 (x2) CBL-SAST-1258LP-100

Option 4: 16 SAS/SATA + 8 SAS/SATA		
Drive Bay #	Drive Type	Part Numbers
Drive Bays 0-15	SAS/SATA (controller 1)	CBL-SAST-1264F-100 CBL-SAST-1276F-100
Drive Bays 16-23	SAS/SATA (controller 2)	CBL-SAST-1296F-100 CBL-CDAT-1062  For Non-RAID: AOC-S3816L-L16IT-O <sup>2</sup> AOC-S3808L-L8IT-O <sup>2</sup>  For Hardware RAID: AOC-S3916L-H16IR-32DD-O <sup>2</sup> AOC-S3908L-H8IR-16DD-O <sup>2</sup>

Option 5: 16 SAS/SATA + 8 NVMe		
Drive Bay #	Drive Type	Part Numbers
Drive Bays 0-15	SAS/SATA	CBL-MCIO-1245M5-M CBL-MCIO-1227M5
Drive Bays 16-23	NVMe (from CPU2)	CBL-MCIO-1218AM5REF CBL-MCIO-1217M5 (x2) CBL-SAST-1264F-100 CBL-SAST-1276F-100  For Non-RAID: AOC-S3816L-L16IT-O <sup>1</sup>  For Hardware RAID: AOC-S3916L-H16IR-32DD-O <sup>1</sup>

<sup>1</sup>AOC needs to be installed in PCIe slot 8, so adding PCIe slot 5-8 with configuration option 1 or 2 is needed.

<sup>2</sup>AOCs need to be installed in PCIe slots 7-8, so adding PCIe slot 5-8 with configuration option 1 or 2 is needed.



Option 6: 16 SAS/SATA + 8 SAS/SATA + 2 NVMe		
Drive Bay #	Drive Type	Part Numbers
Drive Bays 0-15	SAS/SATA (controller 1)	MCP-240-21104-0N BPN-NVME5-826N-B2B
Drive Bays 16-23	SAS/SATA (controller 2)	CBL-MCIO-1217M5 CBL-SAST-1264F-100 CBL-SAST-1276F-100 CBL-SAST-1296F-100 CBL-CDAT-1062 CBL-PWEX-1136YB-30
Rear Drive Bays 0-1	NVMe (from CPU2)	For Non-RAID: AOC-S3816L-L16IT-O <sup>2</sup> AOC-S3808L-L8IT-O <sup>2</sup>  For Hardware RAID: AOC-S3916L-H16IR-32DD-O <sup>2</sup> AOC-S3908L-H8IR-16DD-O <sup>2</sup>



Option 7: 16 SAS/SATA + 8 SAS/SATA + 2 NVMe		
Drive Bay #	Drive Type	Part Numbers
Drive Bays 0-15	SAS/SATA (controller 1)	MCP-240-21104-0N (x2) MCP-120-82927-0N
Drive Bays 16-23	SAS/SATA (controller 2)	BPN-NVME5-826N-B2B (x2) CBL-MCIO-1217M5 CBL-MCIO-1224M5
Rear Drive Bays 0-1	NVMe (from CPU2)	CBL-SAST-1264F-100 CBL-SAST-1276F-100 CBL-SAST-1296F-100 CBL-CDAT-1062 CBL-PWEX-1136YB-30
Rear Drive Bays 2-3	NVMe (from CPU2)	For Non-RAID: AOC-S3816L-L16IT-O <sup>2</sup> AOC-S3808L-L8IT-O <sup>2</sup>  For Hardware RAID: AOC-S3916L-H16IR-32DD-O <sup>2</sup> AOC-S3908L-H8IR-16DD-O <sup>2</sup>

<sup>1</sup>AOC needs to be installed in PCIe slot 8, so adding PCIe slot 5-8 with configuration option 1 or 2 is needed.

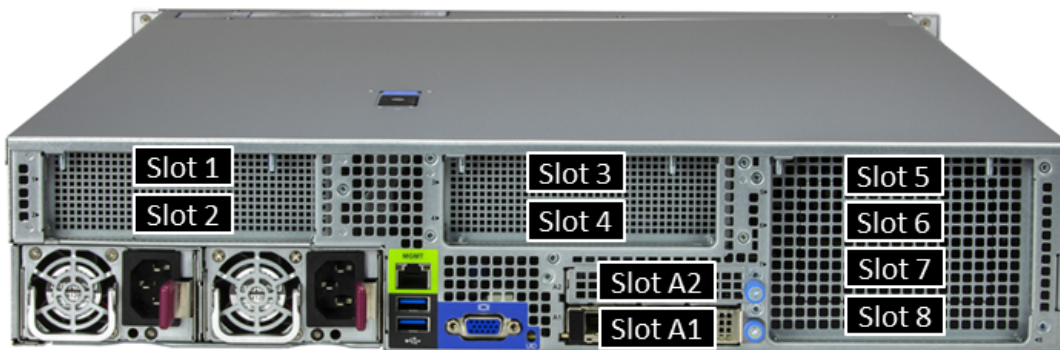
<sup>2</sup>AOCs need to be installed in PCIe slots 7-8, so adding PCIe slot 5-8 with configuration option 1 or 2 is needed.



## Hyper 2U SYS-221H-TN24R PCIe Slot Configuration Options

### For Drive Bay Configuration Option 1 (24 NVMe)

#### Slots 1-2 Configuration Options



Default: No PCIe Slots		
Slot #	Slot Config	Part Numbers
Slot 1	Not Available	MCP-120-21101-0N (Included with system)
Slot 2	Not Available	

*Slots 3-4 Configuration Options*

<b>Default: No PCIe Slots</b>		
<b>Slot #</b>	<b>Slot Config</b>	<b>Part Numbers</b>
Slot 3	Not Available	MCP-120-21101-0N (Included with system)
Slot 4	Not Available	

<b>Option 1: 2 PCIe x8 Slots</b>		
<b>Slot #</b>	<b>Slot Config</b>	<b>Part Numbers</b>
Slot 3	PCIe 5.0 x8 (CPU2)	MCP-240-21108-0N MCP-120-82927-0N RSC-H-68G5
Slot 4	PCIe 5.0 x8 (CPU2)	CBL-GNZ4-1227M5YR21 CBL-PWEX-1136YB-25

<b>Option 2: 1 PCIe x16 Slot</b>		
<b>Slot #</b>	<b>Slot Config</b>	<b>Part Numbers</b>
Slot 3	PCIe 5.0 x16 (CPU2)	MCP-240-21108-0N MCP-120-82927-0N RSC-H-68G5
Slot 4	Not Available	CBL-GNZ4-1227M5YRR16 CBL-PWEX-1136YB-25

*Slots 5-8 Configuration Options*

Default: No PCIe Slots		
Slot #	Slot Config	Part Numbers
Slot 5	Not Available	MCP-120-21902-0N (Included with system)
Slot 6	Not Available	
Slot 7	Not Available	
Slot 8	Not Available	

Option 1: 1 PCIe x16 Slot		
Slot #	Slot Config	Part Numbers
Slot 5	Not Available	MCP-240-21908-0N RSC-H-6G5L
Slot 6	Not Available	
Slot 7	PCIe 5.0 x16 (CPU1)	
Slot 8	Not Available	

Option 2: 2 PCIe x8 Slots		
Slot #	Slot Config	Part Numbers
Slot 5	Not Available	MCP-240-21908-0N RSC-H2-6888G5L
Slot 6	Not Available	
Slot 7	PCIe 5.0 x8 (CPU1)	
Slot 8	PCIe 5.0 x8 (CPU1)	

Slot A1 (AIOM/OCP NIC Slot1) comes with the system.

Slot A2 (AIOM/OCP NIC Slot2) cannot be used in this 24 NVMe drive bay configuration.

**For Drive Bay Configuration Option 2 & 3 (16 NVMe +8 SAS or SATA)***Slots 1-2 Configuration Options*

<b>Default: No PCIe Slots</b>		
<b>Slot #</b>	<b>Slot Config</b>	<b>Part Numbers</b>
Slot 1	Not Available	MCP-120-21101-0N (Included with system)
Slot 2	Not Available	

*Slots 3-4 Configuration Options*

<b>Default: No PCIe Slots</b>		
<b>Slot #</b>	<b>Slot Config</b>	<b>Part Numbers</b>
Slot 3	Not Available	MCP-120-21101-0N (Included with system)
Slot 4	Not Available	

<b>Option 1: 2 PCIe x8 Slots</b>		
<b>Slot #</b>	<b>Slot Config</b>	<b>Part Numbers</b>
Slot 3	PCIe 5.0 x8 (CPU2)	MCP-240-21108-0N MCP-120-82927-0N RSC-H-68G5 CBL-GNZ4-1227M5YR21 CBL-PWEX-1136YB-25
Slot 4	PCIe 5.0 x8 (CPU2)	

<b>Option 2: 1 PCIe x16 Slot</b>		
<b>Slot #</b>	<b>Slot Config</b>	<b>Part Numbers</b>
Slot 3	PCIe 5.0 x16 (CPU2)	MCP-240-21108-0N MCP-120-82927-0N RSC-H-68G5 CBL-GNZ4-1227M5YRR16 CBL-PWEX-1136YB-25
Slot 4	Not Available	

*Slots 5-8 Configuration Options*

Default: No PCIe Slots		
Slot #	Slot Config	Part Numbers
Slot 5	Not Available	MCP-120-21902-0N (Included with system)
Slot 6	Not Available	
Slot 7	Not Available	
Slot 8	Not Available	

Option 1: 4 PCIe x8 Slots		
Slot #	Slot Config	Part Numbers
Slot 5	PCIe 5.0 x8 (CPU1)	MCP-240-21908-0N RSC-H2-6888G5L CBL-MCIO-1222AM5 (x2)
Slot 6	PCIe 5.0 x8 (CPU1)	
Slot 7	PCIe 5.0 x8 (CPU1)	
Slot 8	PCIe 5.0 x8 (CPU1)	

Option 2: 1 PCIe x16 Slot		
Slot #	Slot Config	Part Numbers
Slot 5	PCIe 5.0 x16 (CPU1)	MCP-240-21908-0N RSC-H2-6888G5L CBL-MCIO-1222AM5 CBL-MCIO-1226AM5
Slot 6	Not Available	
Slot 7	PCIe 5.0 x8 (CPU1)	
Slot 8	PCIe 5.0 x8 (CPU1)	

Option 3: 2 PCIe x16 Slots		
Slot #	Slot Config	Part Numbers
Slot 5	PCIe 5.0 x16 (CPU1)	MCP-240-21908-0N RSC-H-68G5 RSC-H-6G5L CBL-MCIO-1226AM5R (x2) CBL-PWEX-1136YB-25
Slot 6	Not Available	
Slot 7	PCIe 5.0 x16 (CPU1)	
Slot 8	Not Available	

Slot A1 (AIOM/OCP NIC Slot 1) comes with the system.

Slot A2 (AIOM/OCP NIC Slot 2) cannot be used in this 16 NVMe drive bay configuration.

**For Drive Bay Configuration Options excluding 24 NVMe & 16 NVMe***Slots 1-2 Configuration Options*

<b>Default: No PCIe Slots</b>		
<b>Slot #</b>	<b>Slot Config</b>	<b>Part Numbers</b>
Slot 1	Not Available	MCP-120-21101-0N (Included with system)
Slot 2	Not Available	

<b>2 PCIe x8 Slots</b>		
<b>Slot #</b>	<b>Slot Config</b>	<b>Part Numbers</b>
Slot 1	PCIe 5.0 x8 (CPU2)	MCP-240-21108-0N RSC-H-68G5
Slot 2	PCIe 5.0 x8 (CPU2)	CBL-MCIO-1233M5R CBL-MCIO-1232M5 CBL-PWEX-1136YB-25 <sup>1,2</sup>

<b>1 PCIe x16 Slot</b>		
<b>Slot #</b>	<b>Slot Config</b>	<b>Part Numbers</b>
Slot 1	PCIe 5.0 x16 (CPU2)	MCP-240-21108-0N RSC-H-68G5
Slot 2	Not Available	CBL-MCIO-1233M5R (x2) CBL-PWEX-1136YB-25 <sup>1,2</sup>

*Slots 5-8 Configuration Options*

Default: No PCIe Slots		
Slot #	Slot Config	Part Numbers
Slot 5	Not Available	MCP-120-21902-0N (Included with system)
Slot 6	Not Available	
Slot 7	Not Available	
Slot 8	Not Available	

Option 1: 4 PCIe x8 Slots		
Slot #	Slot Config	Part Numbers
Slot 5	PCIe 5.0 x8 (CPU1)	MCP-240-21908-0N RSC-H2-6888G5L CBL-MCIO-1222AM5 (x2)
Slot 6	PCIe 5.0 x8 (CPU1)	
Slot 7	PCIe 5.0 x8 (CPU1)	
Slot 8	PCIe 5.0 x8 (CPU1)	

Option 2: 1 PCIe x16 Slot & 2PCIe x8 Slots		
Slot #	Slot Config	Part Numbers
Slot 5	PCIe 5.0 x16 (CPU1)	MCP-240-21908-0N RSC-H2-6888G5L CBL-MCIO-1222AM5 CBL-MCIO-1226AM5
Slot 6	Not Available	
Slot 7	PCIe 5.0 x8 (CPU1)	
Slot 8	PCIe 5.0 x8 (CPU1)	

Option 3: 2 PCIe x16 Slots		
Slot #	Slot Config	Part Numbers
Slot 5	PCIe 5.0 x16 (CPU1)	MCP-240-21908-0N RSC-H-68G5 RSC-H-6G5L CBL-MCIO-1226AM5R (x2) CBL-PWEX-1136YB-25 <sup>2</sup>
Slot 6	Not Available	
Slot 7	PCIe 5.0 x16 (CPU1)	
Slot 8	Not Available	

<sup>1</sup> If Slots 1-2 & Slots 3-4 are both enabled, replace PWEX-1136YB-25 with one power cable CBL-PWEX-1136YB-25 to share between two RSC-H-68G5.

<sup>2</sup> If Slots 1-2 & Slots 3-4 & Slots 5-8 Option 3 are enabled then you only need one power cable CBL-PWEX-1136YVB-45 to share between three RSC-H-68G5.

Slot A1 (AIOM/OCP NIC Slot1) comes with the system.

Slot A2 (AIOM/OCP NIC Slot2) is optional except cannot be used in eight NVMe drive bay configuration. To enable this slot add MCP-120-82926-0N, CBL-CDAT-1060-30, CBL-MCIO-1218M5-1, CBL-MCIO-1221M5, AOM-AIOM-2X8-G5-P.

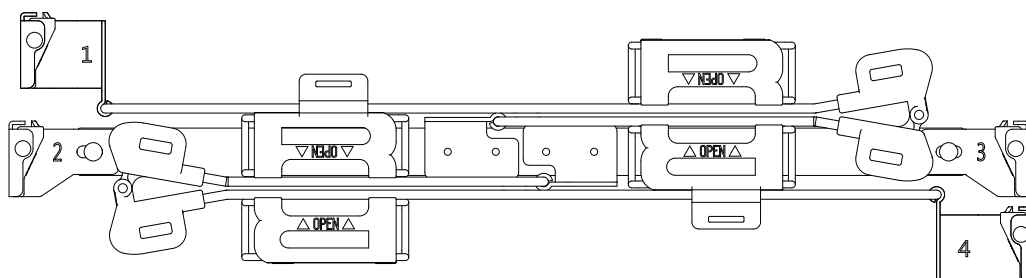
## 6.3 Power Supply Configurations

Power Supply Module Options		
Watts	Part Number	80Plus Level
1200	PWS-1K24A-1R (default in SYS-221H-TNR)	Titanium
1600	PWS-1K63A-1R (default in SYS-221H-TN24R)	Titanium
2000	PWS-2K07A-1R	Titanium
2600	PWS-2K63A-1R	Titanium

## 6.4 Cable Management Arm

The system supports a cable management arm (CMA), which keeps the rear cables organized and clear of the rail mechanisms when the system is extended out the front of the rack for maintenance.

The CMA attaches to the rack mounting rails using four connectors. They are labeled on the connectors 1, 2, 3, and 4.



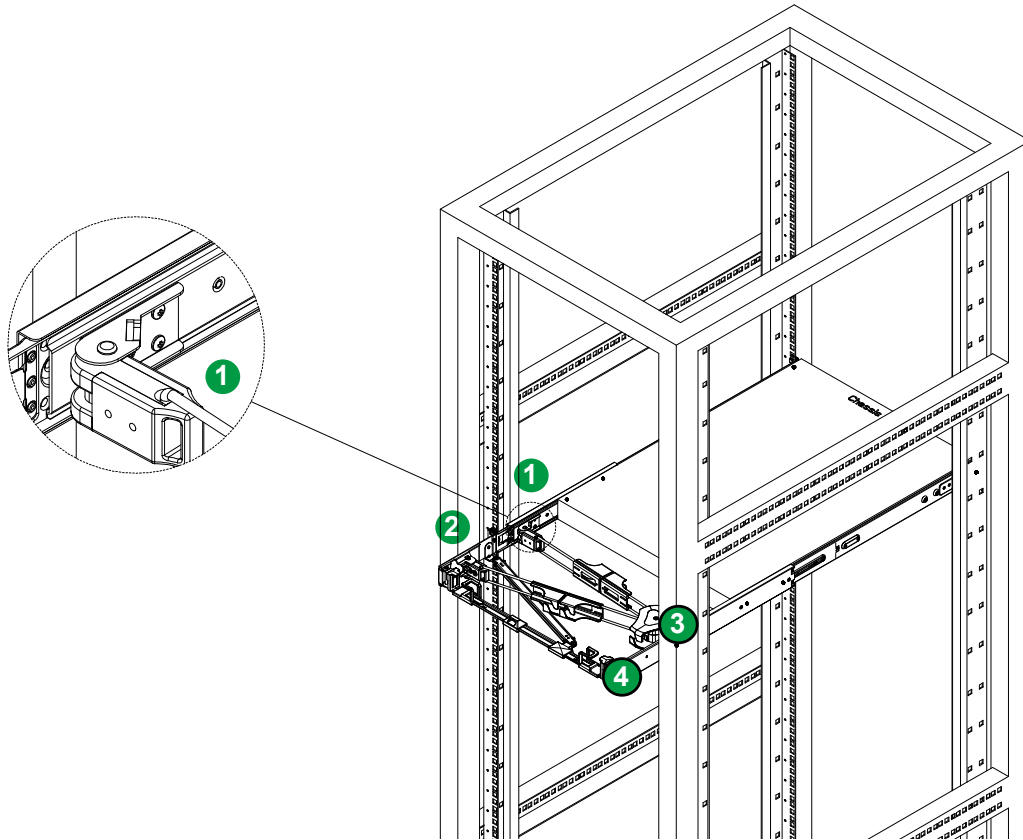
**Figure 6-1. Cable Management Arm**

Cable Arm Details		
Optional Part	Part Number	Description
Cable Arm	MCP-290-00168-0N	7.5" deep cable arm
Rail Set	MCP-290-11901-0N	41.2" rails (optimized for 1200 mm deep racks)

### ***Installing the Cable Management Arm***

1. Slide CMA connector #1 forward onto the two posts on the rear of the right inner rail (right side when viewed from the front). It snaps into place.
2. Slide CMA connector #2 forward onto the two posts on the rear of the right middle rail. It snaps into place.





**Figure 6-2. Installing the Connectors**

3. Slide CMA connector #3 forward onto the two posts on the rear of the left middle rail. It snaps into place.
4. For CMA connector #4, align the metal tabs with the slots on the rear of the left outer rail and push it forward. It snaps into place.
5. Route the cables through the holding brackets, leaving enough slack.

### ***Removing the Cable Management Arm***

1. Remove cables from the CMA,
2. For CMA connector #4, pull the metal release tab toward the center of the rack and slide the connector toward the rear to release it.
3. For CMA connectors #3, #2, and #1, depress the front edge of the yellow plastic rocker lock and slide the connector toward the rear to release it.

## 6.5 TPM Security Module

SPI capable TPM 2.0 with Infineon 9672 controller, vertical form factor.

The JTPM1 header is used to connect a Trusted Platform Module (TPM). A TPM is a security device that supports encryption and authentication in hard drives. It enables the motherboard to deny access if the TPM associated with the hard drive is not installed in the system.

Details and installation procedures are at:

<http://www.supermicro.com/manuals/other/TPM.pdf>.

- AOM-TPM-9672V-O
- AOM-TPM-9672V-FIPS-O

## 6.6 Intel Virtual RAID on CPU (VROC)

Intel® Virtual RAID on CPU (Intel VROC) is an enterprise RAID solution for NVMe SSDs directly attached to Intel Xeon Scalable processors. Intel Volume Management Device (VMD) is an integrated controller inside the CPU PCIe root complex.

- A single processor supports up to 12 NVMe SSDs and up to 6 RAID arrays.
- A dual processor system supports up to 24 NVMe SSDs and 12 RAID arrays.

Stripe sizes are 4K, 8K, 16K, 32K, 64K, 128K.

### Requirements and Restrictions

- **Intel VROC is only available when the system is configured for UEFI boot mode.**
- To enable the **mdadm** command and support for RSTe, install the patch from
  - Linux: <https://downloadcenter.intel.com/download/28158/Intel-Virtual-RAID-on-CPU-Intel-VROC-and-Intel-Rapid-Storage-Technology-enterprise-Intel-RSTe-Driver-for-Linux->
  - Windows: <https://downloadcenter.intel.com/download/28108/Intel-Virtual-RAID-on-CPU-Intel-VROC-and-Intel-Rapid-Storage-Technology-enterprise-Intel-RSTe-Driver-for-Windows->
- To enable Intel VROC, a hardware key must be inserted on the motherboard, and the appropriate processor's Virtual Management Devices must be enabled in the BIOS setup.
- It is possible to enable Intel VROC without a hardware key installed, but only RAID0 will be enabled.
- Intel VROC is not compatible with secure boot. This feature must be disabled.
- When creating bootable OS RAID1 devices, you must have both devices on the same CPU, and a VMD on that CPU.
- Spanning drives when creating RAID devices is not recommended due to performance issues, even though it is supported.

### Supported SSDs and Operating Systems

To see the latest support information: <https://www.intel.com/content/www/us/en/support/articles/000030310/memory-and-storage/ssd-software.html>

## Additional Information

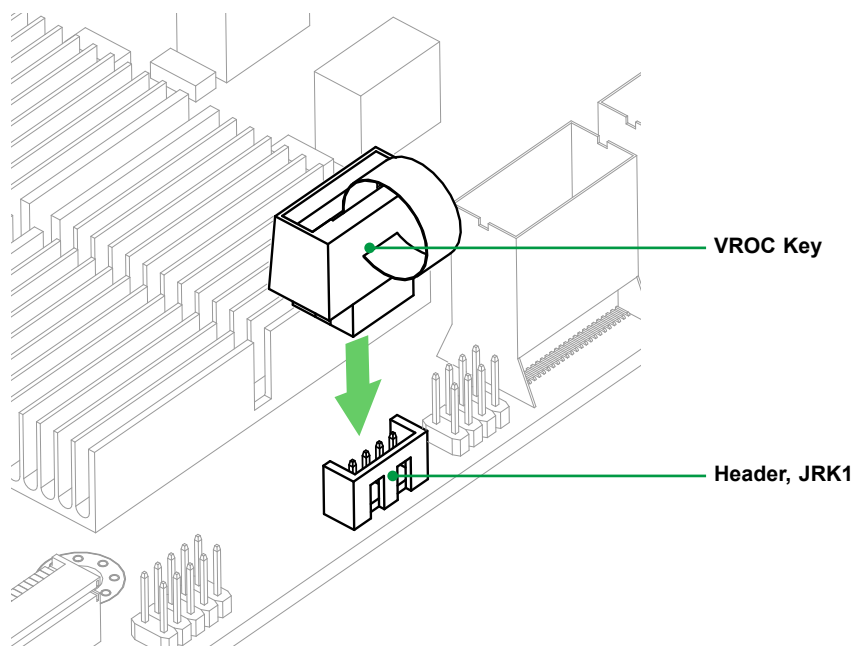
Additional information is available on the product page for the Supermicro add-on card and the linked manuals.

[www.supermicro.com/products/accessories/addon/AOC-VROCxxxMOD.cfm](http://www.supermicro.com/products/accessories/addon/AOC-VROCxxxMOD.cfm)

## Hardware Key

The Intel VROC hardware key is a license key that detects the Intel VROC SKU and activates the function accordingly. The key must be plugged into the Supermicro motherboard (connector JRK1). The key options are:

Intel® VROC Keys			
VROC Package	Description	Part Number	Intel MM Number
Standard	RAID 0, 1, 10 Supports 3rd party SSDs	AOC-VROCSTNMOD	951605
Premium	RAID 0, 1, 5, 10 Supports 3rd party SSDs	AOC-VROCPREMOD	951606
Intel SSD only	RAID 0, 1, 5, 10 Supports Intel SSDs only	AOC-VROCINTMOD	956822



**Figure 6-3. Intel VROC RAID Key and Motherboard Connector JRK1**

## Configuring Intel VMD

VMD must be enabled on PCIe ports which have NVMe drives attached to them in order for those drives to be added to a VROC RAID configuration. The default BIOS setting for the NVMe Mode Switch is **Auto** which automatically enables VMD on all installed NVMe drives.

NVMe Mode Switch:

- **Auto** Enables VMD for all NVMe ports if VROC Key is installed.
- **VMD** Enables VMD for all NVMe ports despite the lack of the VROC Key.
- **Manual** Allows the user to select specific NVMe ports on which to enable VMD.

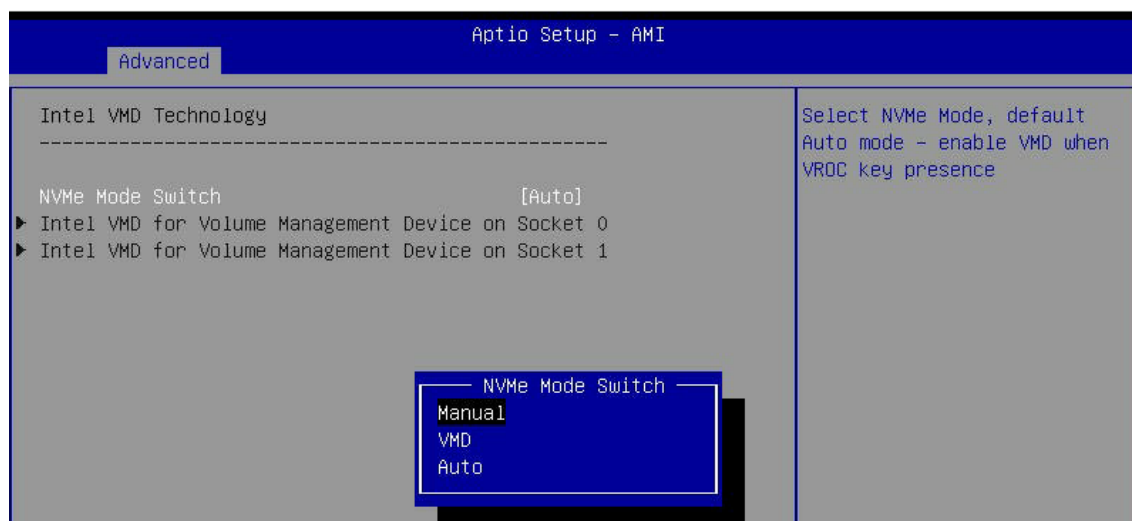
The NVMe Mode Switch can be viewed or selected at **BIOS > Advanced > Chipset Configuration > North Bridge > IIO Configuration > Intel® VMD Technology**.

**Note:** Without a VROC Key, there is no RAID support with the Auto switch. Only RAID 0 is supported with the **VMD** and **Manual** switches.

### Configuring VMD Manually

The steps for manually configuring VMD on specific NVMe ports in UEFI BIOS are shown below. Example screenshots may differ from your server.

1. Reboot the server and press [DEL] key to access the BIOS options.
2. Switch to **Advanced > Chipset Configuration > North Bridge > IIO Configuration > Intel® VMD Technology**.
3. Select **VMD Mode Switch**, then select **Manual**.



Note that Socket 0 contains CPU1; Socket 1 contains CPU2

**Figure 6-4. BIOS, Selecting VMD Mode**

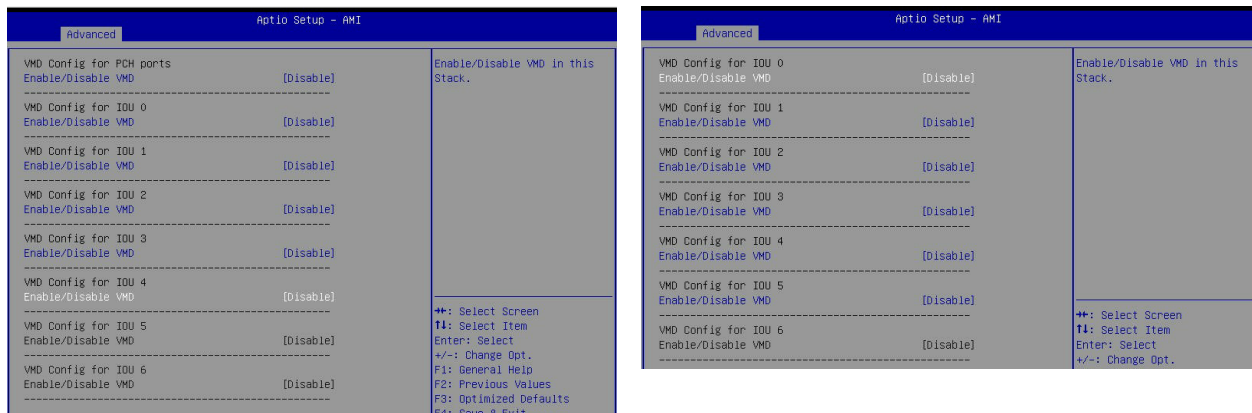
This table identifies the NVMe Port Resources in the X13 Hyper servers. Enable VMD on the NVMe drive's corresponding hardware stack according to the VMD BIOS Settings table.

Intel VMD BIOS Settings for X13 Hyper Systems				
Model	CPU1	NVMe Slots	CPU2	NVMe Slots
<b>SYS-121H-TNR</b> 8 NVMe (0-7) 12 NVMe (0-11) 8 SAS/SATA + 4 NVMe (8-11) 8 SATA + 4 NVMe (8-11) 8 NVMe (0-7) + 4 SAS/SATA 8 NVMe (0-7) + 4 SATA	VMD Config for PCH ports: PCH Root Port 8 PCH Root Port 9	M.2 A,B	VMD Config for IOU 0: Socket 1 IOU0 port A Socket 1 IOU0 port C Socket 1 IOU0 port E Socket 1 IOU0 port G	NVMe 4,5,6,7
	VMD Config for IOU 3: Socket 0 IOU3 port E Socket 0 IOU3 port G	NVMe 0,1.	VMD Config for IOU 3: Socket 1 IOU3 port E Socket 1 IOU3 port G	NVMe 8,9.
	VMD Config for IOU 4: Socket 0 IOU4 port A Socket 0 IOU4 port C	NVMe 2, 3	VMD Config for IOU 4: Socket 1 IOU4 port E Socket 1 IOU4 port G	NVMe 10,11
<b>SYS-621H-TN12R</b> 12 NVMe (0-11) 8 SAS/SATA + 4 NVMe (8-11) 8 SATA + 4 NVMe (8-11)	VMD Config for PCH ports: PCH Root Port 8 PCH Root Port 9	M.2 A,B	VMD Config for IOU 3: Socket 1 IOU3 port E Socket 1 IOU3 port G	NVMe 6, 7
	VMD Config for IOU 3: Socket 0 IOU3 port E Socket 0 IOU3 port G	NVMe 0,1	VMD Config for IOU 4: Socket 1 IOU4 port A Socket 1 IOU4 port C Socket 1 IOU4 port E Socket 1 IOU4 port G	NVMe 8,9,10,11
	VMD Config for IOU 4: Socket 0 IOU4 port A Socket 0 IOU4 port C Socket 0 IOU4 port E Socket 0 IOU4 port G	NVMe 2,3,4,5		
<b>SYS-621H-TN12R</b> 2 Rear NVMe (12-13) 4 Rear NVMe (12-15)	VMD Config for PCH ports: PCH Root Port 8 PCH Root Port 9	M.2 A,B	VMD Config for IOU 0: Socket 1 IOU0 port A Socket 1 IOU0 port C Socket 1 IOU0 port E Socket 1 IOU0 port G	NVMe 12,13,14,15
<b>SYS-221H-TN24R</b> 24 NVMe (0-23) 16 NVMe (8-23) + 8 SAS/SATA 16 NVMe (8-23) + 8 SATA 16 SAS/SATA + 8 NVMe (16-23)	VMD Config for PCH ports: PCH Root Port 8 PCH Root Port 9	M.2 A,B	VMD Config for IOU 0: Socket 1 IOU0 port A Socket 1 IOU0 port C Socket 1 IOU0 port E Socket 1 IOU0 port G	NVMe 10,11,12,13
	VMD Config for IOU 1: Socket 0 IOU1 port A Socket 0 IOU1 port C Socket 0 IOU1 port E Socket 0 IOU1 port G	NVMe 0,1,2,3	VMD Config for IOU 2: Socket 1 IOU2 port A Socket 1 IOU2 port C Socket 1 IOU2 port E Socket 1 IOU2 port G	NVMe 14,15,16,17
	VMD Config for IOU 3: Socket 0 IOU3 port E Socket 0 IOU3 port G	NVMe 4,5	VMD Config for IOU 3: Socket 1 IOU3 port E Socket 1 IOU3 port G	NVMe 18,19
	VMD Config for IOU 4: Socket 0 IOU4 port A Socket 0 IOU4 port C Socket 0 IOU4 port E Socket 0 IOU4 port G	NVMe 6,7,8,9	VMD Config for IOU 4: Socket 1 IOU4 port A Socket 1 IOU4 port C Socket 1 IOU4 port E Socket 1 IOU4 port G	NVMe 20,21,22,23

Intel VMD BIOS Settings for X13 Hyper Systems				
Model	CPU1	NVMe Slots	CPU2	NVMe Slots
<b>SYS-221H-TN24R</b> 2 Rear NVMe (24-25) 4 Rear NVMe (24-27)	VMD Config for PCH ports: PCH Root Port 8 PCH Root Port 9	M.2 A,B	VMD Config for IOU 0: Socket 1 IOU0 port A Socket 1 IOU0 port C Socket 1 IOU0 port E Socket 1 IOU0 port G	NVMe 24,25,26,27
<b>SYS-221H-TNR</b> 16 NVMe (0-15) 8 NVMe (8-15) + 8 SAS/SATA 8 NVMe (8-15) + 8 SATA	VMD Config for PCH ports: PCH Root Port 8 PCH Root Port 9	M.2 A,B	VMD Config for IOU 2: Socket 1 IOU2 port A Socket 1 IOU2 port C Socket 1 IOU2 port E Socket 1 IOU2 port G	NVMe 6,7,8,9
	VMD Config for IOU 3: Socket 0 IOU3 port E Socket 0 IOU3 port G	NVMe 0,1	VMD Config for IOU 3: Socket 1 IOU3 port E Socket 1 IOU3 port G	NVMe 10,11
	VMD Config for IOU 4: Socket 0 IOU4 port A Socket 0 IOU4 port C Socket 0 IOU4 port E Socket 0 IOU4 port G	NVMe 2,3,4,5	VMD Config for IOU 4: Socket 1 IOU4 port A Socket 1 IOU4 port C Socket 1 IOU4 port E Socket 1 IOU4 port G	NVMe 12,13,14,15
<b>SYS-221H-TNR</b> 8 NVMe	VMD Config for PCH ports: PCH Root Port 8 PCH Root Port 9	M.2 A,B	VMD Config for IOU 2: Socket 1 IOU2 port E Socket 1 IOU2 port G	NVMe 0,1
			VMD Config for IOU 3: Socket 1 IOU3 port E Socket 1 IOU3 port G	NVMe 2,3
			VMD Config for IOU 4: Socket 1 IOU4 port A Socket 1 IOU4 port C Socket 1 IOU4 port E Socket 1 IOU4 port G	NVMe 4,5,6,7

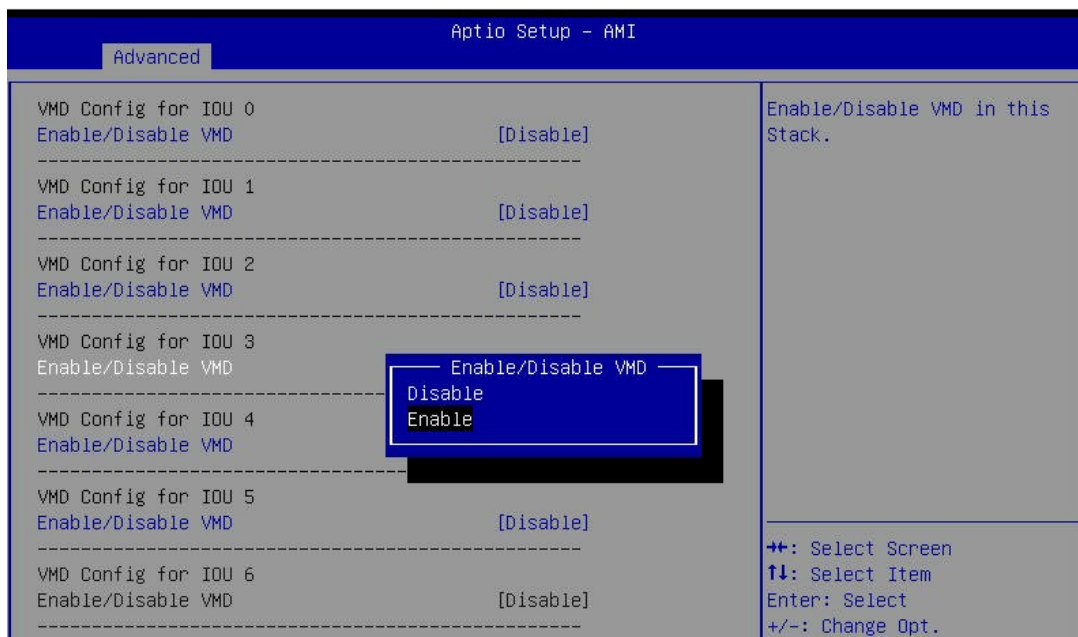
**Caution:** VMD must only be enabled on NVMe port resources. If VMD is enabled on other PCIe ports, the functionality of those ports will be impacted.

- Select “Intel VMD for Volume Management Device on” on Socket 0 (CPU1) or Socket 2 (CPU2) to enable VMD for devices under the respective CPU.



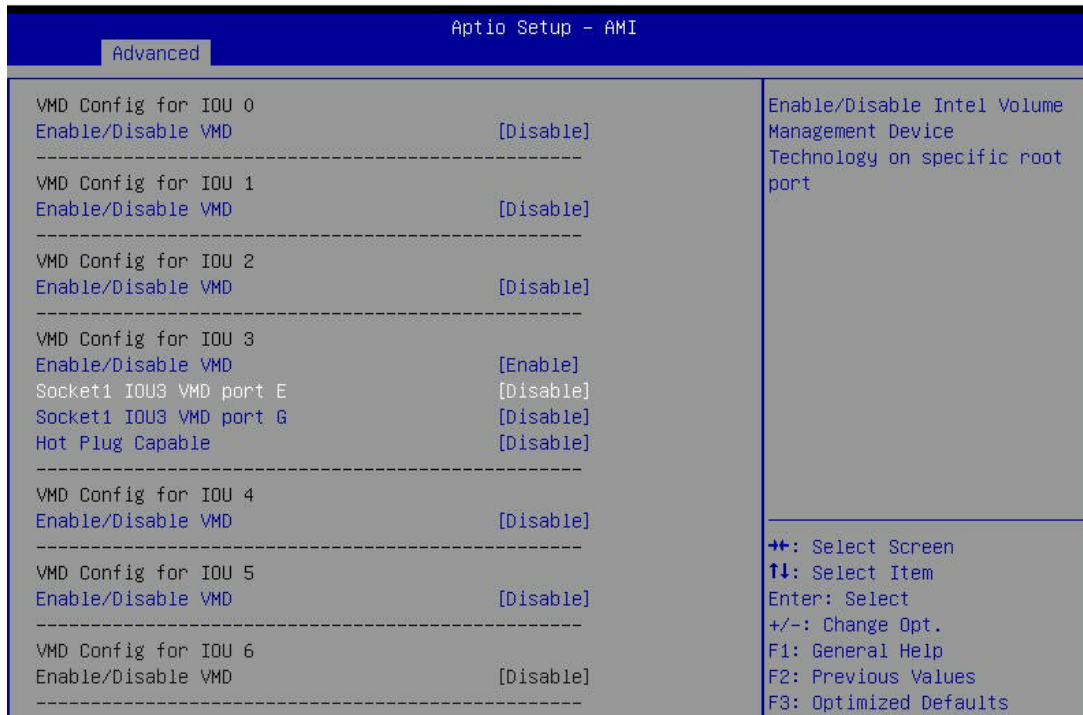
**Figure 6-5. Intel VMD for Volume Management Device on Socket 0 and Socket 1**

- Choose Enable for “Enable/Disable VMD” for IOU 3 to list the available devices under IOU 3.



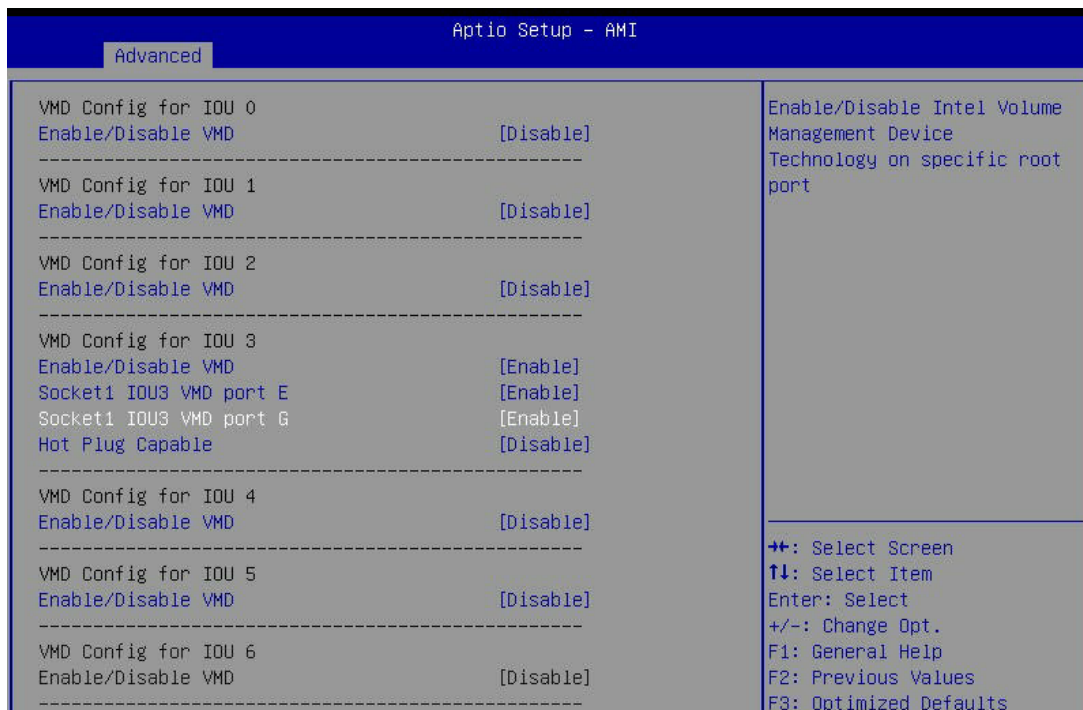
**Figure 6-6. BIOS, Enabling VMD on Socket 1 (CPU2) (Example)**





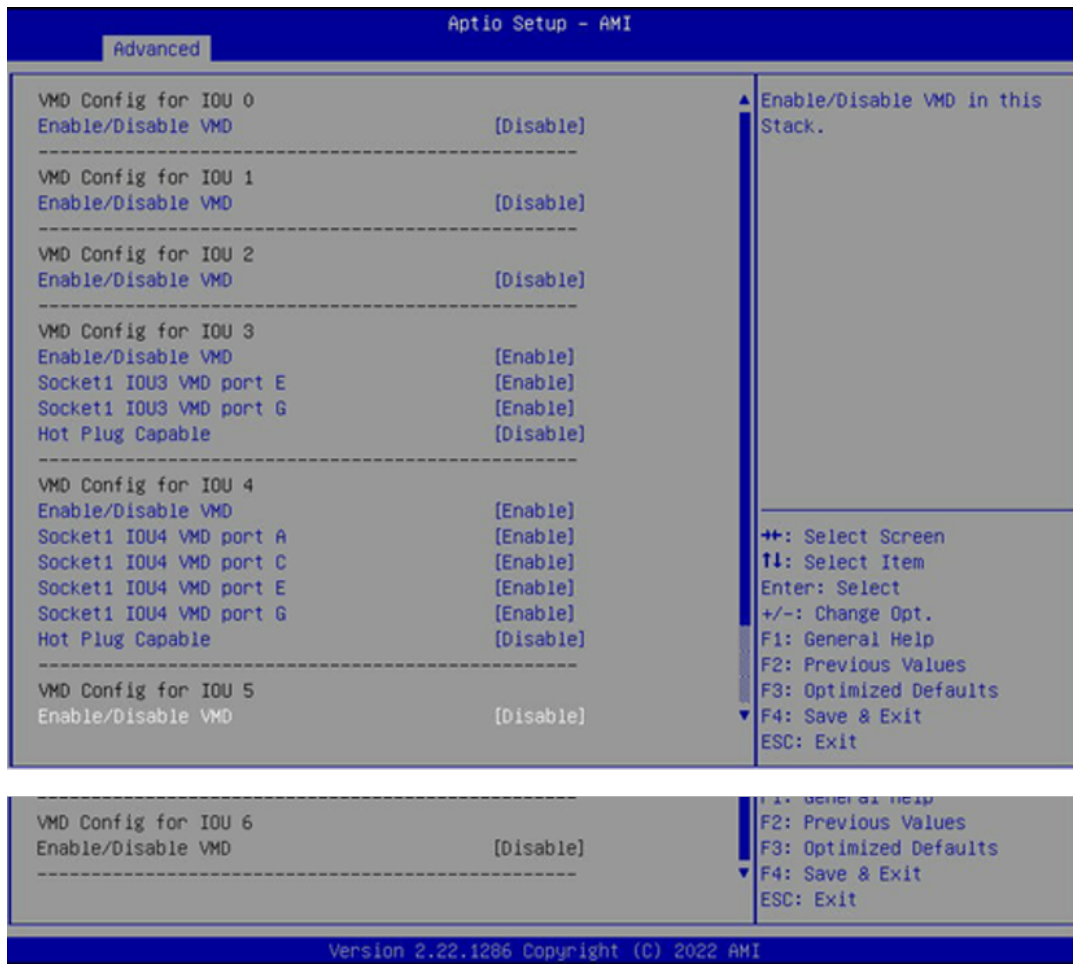
**Figure 6-7. BIOS, Enabling VMD on Socket 1 (Example)**

6. Enable the NVMe port resource according to table above for the NVMe drives that will be used in a RAID configuration.



**Figure 6-8. BIOS, Enabling Socket 1 (Example)**

7. Choose whether to make the NVMe drives in this IOU **Hot Plug Capable** by selecting Enabled or Disabled.
8. Repeat steps 4 through 7 for each IOU # on each CPU to enable VMD on the desired NVMe ports.



**Figure 6-9. BIOS, Enabling Socket 1 Completed (Example)**  
 (This example shows SYS-621H-TN12R with 12 NVMe. Other systems will look different.)

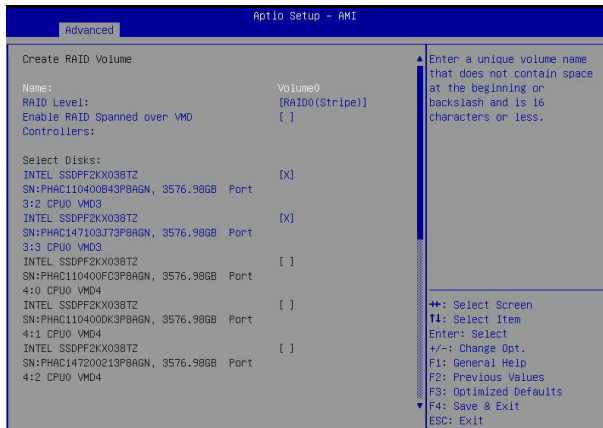
9. Press [F4] to save the configuration and reboot the system.

**Note:** If there is an existing RAID configuration, delete the RAID volume associated with the VMD controller before disabling the controller. Failure to do so may lead to unexpected behavior.

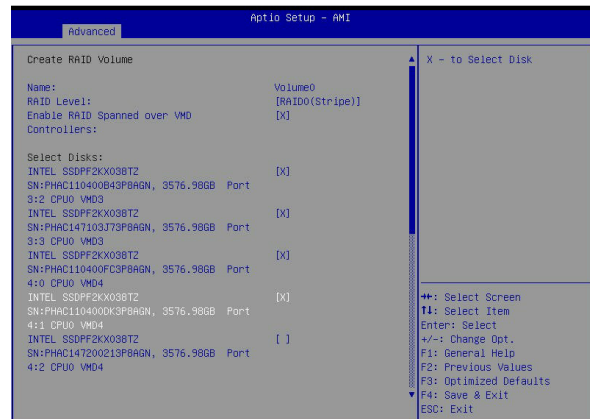
**Note:** The effects of physically changing or swapping a CPU on the VMD controller have not been thoroughly tested or documented.

## Creating NVMe RAID Configurations

1. Open **Advanced > Intel(R) Virtual RAID on CPU > All Intel VMD Controllers > Create RAID Volume**.



**Figure 6-10. Created Volume without enabling RAID spanned over VMD controller**



**Figure 6-11. Created Volume with enabling RAID spanned over VMD controller**

2. Set **Name**.
3. Set **RAID Level**.
4. If cross-controller RAID is required, select **Enable RAID spanned over VMD Controller**.
5. Select specific disks for RAID with an [X].
  - RAID0: Select at least two [2 - 24] disks
  - RAID1: Select only two disks
  - RAID5: Select at least three [3 - 24] disks
  - RAID10: Select only four disks
6. Select **Strip Size** (Default 64KB).
7. Select **Create Volume**.
8. If another RAID is needed, start again at step 1.

## Status Indications

An LED indicator on the drive carrier shows the RAID status of the drive.

Drive Carrier Status LED Indicator	
Status	State (red)
Normal function	OFF
Locating	4 Hz blink
Fault	Solid ON
Rebuilding	1 Hz Blink

IBPI SFF 8489 Defined Status LED States

## Hot-Swap Drives

Intel VMD enables hot-plug and hot-unplug for NVMe SSDs, whether from Intel or other manufacturers. Under vSphere ESXi, several steps are necessary to avoid potential stability issues. See the information at the link [1] below.

### Hot-unplug

1. Prevent devices from being re-detected during rescan:

```
esxcli storage core claiming autoclaim --enabled=false
```

2. Unmount the VMFS volumes on the device. Check [2] for details.
3. Detach the device. Check [3] for details.
4. Physically remove the device.

### Hot-plug

- Physically install the device.

ESXi will automatically discover NVMe SSDs, but a manual scan may be required in some cases.

## Related Information Links

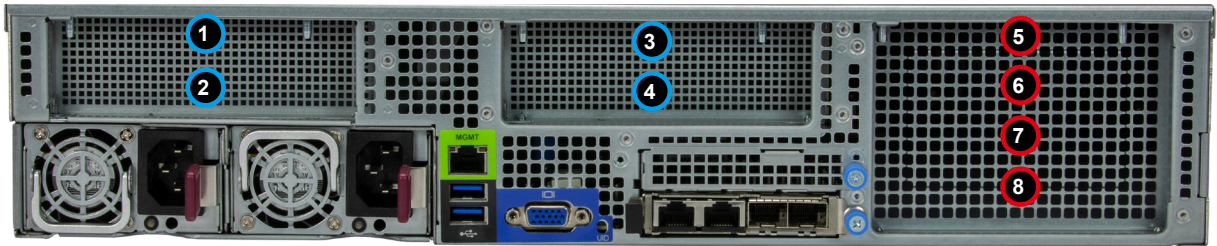
[1] <https://kb.vmware.com/s/article/2151404>

[2] <https://docs.vmware.com/en/VMware-vSphere/6.5/com.vmware.vsphere.storage.doc/GUID-1B56EF97-F60E-4F21-82A7-8F2A7294604D.html>

[3] <https://docs.vmware.com/en/VMware-vSphere/6.5/com.vmware.vsphere.storage.doc/GUID-F2E75F67-740B-4406-9F0C-A2D99A698F2A.html>

## 6.7 GPUs

Supermicro 2U Hyper systems support graphic processing units (GPUs) when installed with some additional optional parts. GPUs have cooling requirements that can be assisted by specialized dual-level air shrouds to direct the flow from the system fans. Refer to the Supermicro product page to see the list of compatible GPUs.



**Figure 6-12. Expansion Card Chassis Slots**

- Single width GPUs can be installed the same as PCIe expansion cards.
- Double width GPUs can be used in slots 1, 3, 5, and 7. When a slot is used the corresponding even numbered slot is not available.

### Notes:

- Installing different types of GPUs is not recommended.
- Due to thermal limitations, not all slots can be filled for some GPU models.
- Some GPUs require alternate air shrouds, CPU heatsinks, and restrictions on the physical size of storage drives.
- Standard air shrouds are MCP-310-82938-0N (CPU1) and MCP-310-82039-0N (CPU2).
- 1U air shrouds are MCP-310-82940-0N and MCP-310-82941-0N.

### Installing GPUs

1. Power down the system, unplug AC cords, and remove the top chassis cover.
2. Following the instructions in Expansion Card section in Chapter 3, install the GPU in the recommended PCIe slot according to the GPU support table below.

**Note:** Install the GPU support bracket for 9.5" or longer GPUs installed in Slots 5 and 7. A single bracket can support a card in either or both.

Supported GPU Configurations (SYS-221H-TNR)							
GPU Types	QTY	Slots	GPU Max Power	CPU Power	System Ambient	Air Shrouds	Storage
Double Wide (passive)	4	1,3,5,7	350 W	165 W	25C	Standard	Up to 8 Drives (0-7)
Double Wide (passive)	up to 3	1,3,5 (only)	350 W	300 W	30C	1U GPU Air shroud/1U Heatsinks	
Double Wide (active)	up to 4	1,3,5,7	350 W	350 W	25C	Standard	
Single Wide	8	1,2,3,4,5,6,7,8	165 W	350 W	25C	Standard	
Single Wide	up to 6	1,2,3,4,5,6 (only)	165 W	300 W	30C	1U GPU Air shroud/1U Heatsinks	
Single Wide	2	7,8	165 W	350 W	25C	Standard	

**Note 1:** See Supermicro GPU support webpage for CPU Power and System Ambient Limits for specific GPU models.

**Note 2:** Only one 8-disk backplane is supported with GPUs.

- Install the power cables provided with GPU cards according to the table below. See the [motherboard layout](#) in Chapter 1 to identify the connectors. Some GPU models may not require power cables.

GPU Cable Connections				
GPU	Motherboard Connector	GPU Connector Type		
		PCIe 16-pin PWR	PCIe 6-pin/8-pin PWR	CPU 8-pin PWR
GPU in Slot 1	JPMW5	CBL-PWEX-1364-26	CBL-PWEX-1171-2654	CBL-PWEX-1172-2654
GPU in Slot 3	JPMW2			
GPU in Slot 5	JPMW4	CBL-PWEX-1364-12		
GPU in Slot 7	JPMW7			

4. Determine if your GPUs require replacing the default 2U air shrouds (see [previous table](#)). To replace:

- a. Remove the default air shrouds and discard.
- b. Replace both 2U CPU heatsinks with 1U heatsinks (see [procedure](#)).
- c. For the 1U GPU air shrouds, use the table below to determine if the air blocks should remain in the blocking position, or be stored in non-blocking position.

GPU Air Block Configurations					
GPU Configuration	QTY	Slots	Fan 8 Air Block	Fan 6 Air Block	Fan 4 Air Block
Double Wide	3	1,3,5	Stored	Stored	Stored
Double Wide	2	3,5	Stored	Stored	Blocked
Double Wide	1	5	Stored	Blocked	Blocked
Single Wide	5 or 6	1,(2),3,4,5,6	Stored	Stored	Stored
Single Wide	3 or 4	3, (4), 5, 6	Stored	Stored	Blocked
Single Wide	1 or 2	5, (6)	Stored	Blocked	Blocked

- Air blocks are only available on 1U GPU air shrouds.
- Stored means the air block is hidden and not impeding airflow.

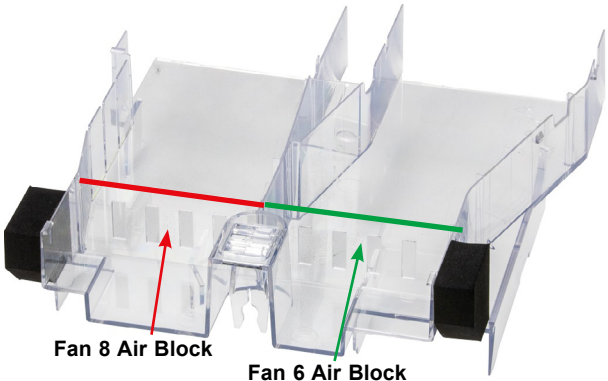
- d. Install the the 1U air shroud MCP-310-82940-0N (Fan 8 and Fan 6 air blocks) over CPU1.
- e. Install the the 1U air shroud MCP-310-82941-0N (Fan 4 air blocks) over CPU2.

5. Close and power up the system.

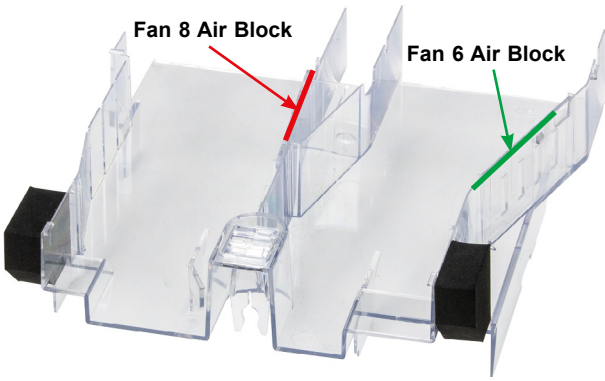
**Storing the Air Blocks for 1U GPU Air Shrouds**

Remove the air shroud top cover. If an air block must be stored, lift it out of the blocking position and snap it into the stored position as shown below.

*Air shroud MCP-310-82940-0N (top removed)*

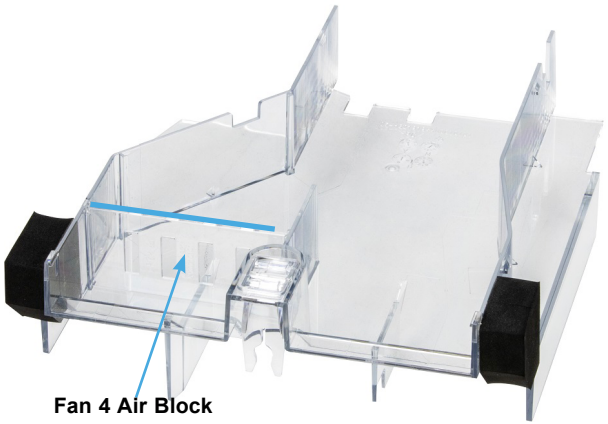


**Figure 6-13. Fan 8 and 6 Air Blocks, Blocking Position**

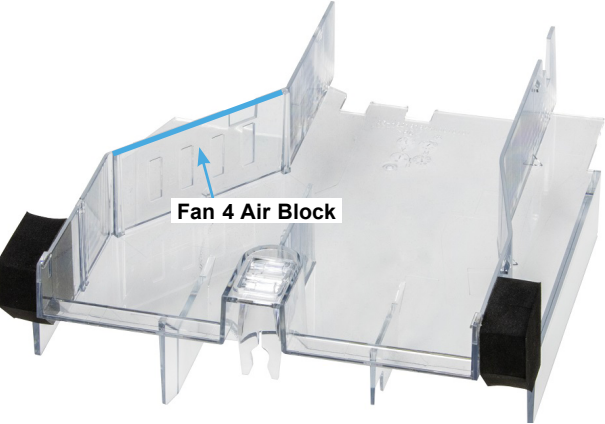


**Figure 6-14. Fan 8 and 6 Air Blocks, Stored Position**

*Air shroud MCP-310-82941-0N (top removed)*



**Figure 6-15. Fan 4 Air Block, Blocking Position**



**Figure 6-16. Fan 4 Air Block, Stored Position**



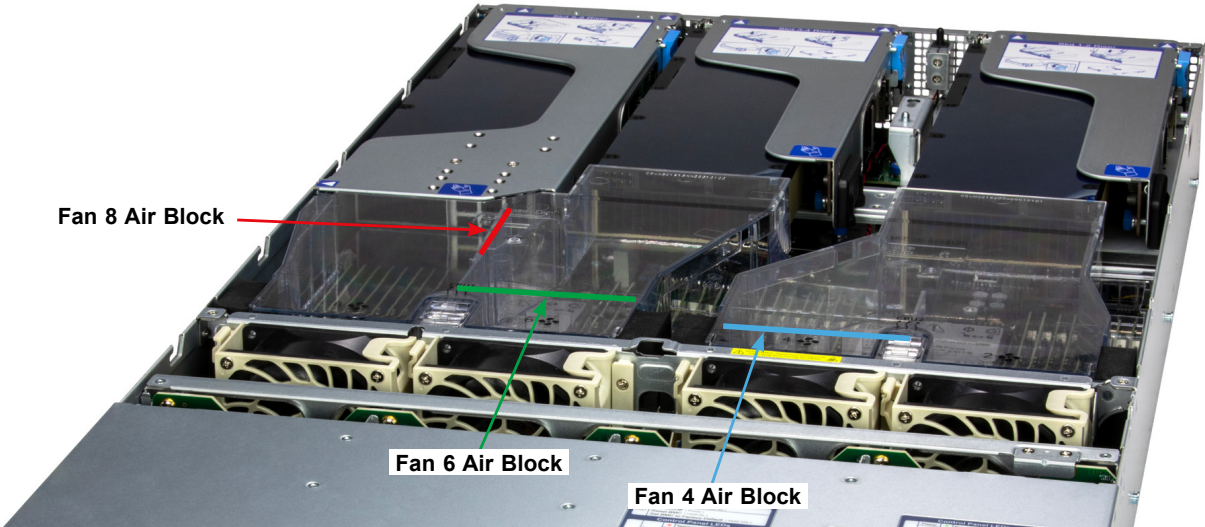


Figure 6-17. Fan 8 Air Block Stored; Fan 6 and Fan 4 Air Block in Blocking Position

# Chapter 7

## Troubleshooting and Support

### 7.1 Information Resources

#### Website

A great deal of information is available on the Supermicro [website](#).

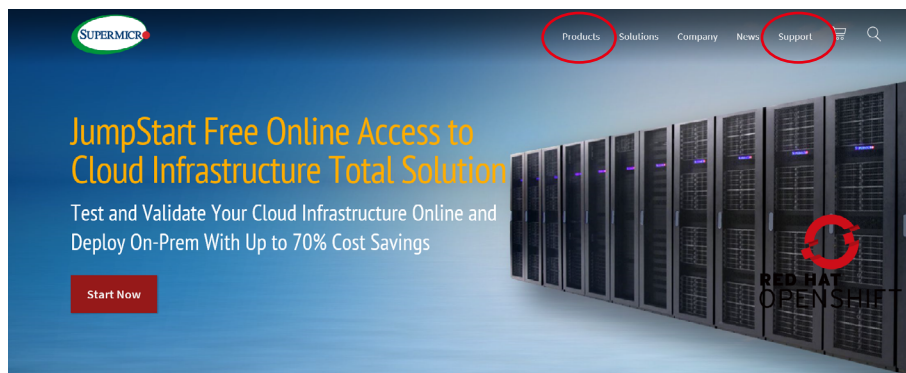


Figure 7-1. Supermicro Website

- Specifications for servers and other hardware are available by clicking **Products** option.
- The **Support** option offers downloads (manuals, BIOS/BMC, drivers, etc.), FAQs, RMA, warranty, and other service extensions.

#### ***Direct Links for the SYS-221H-T Series System***

[SYS-221H-TNR](#) specifications page

[SYS-221H-TN24R](#) specifications page

[X13DEM](#) motherboard page for links to the Quick Reference Guide, User Manual, validated storage drives, etc.

#### ***Direct Links for General Support and Information***

[Frequently Asked Questions](#)

[TPM User Guide](#)

[BMC User Guide](#)

[SuperDoctor5 Large Deployment Guide](#)

For validated memory, see our [Product Resources](#) page

### Direct Links (continued)

[Product Matrices](#) page for links to tables summarizing specs for systems, motherboards, power supplies, riser cards, add-on cards, etc.

[Security Center](#) for recent security notices

[Supermicro Phone and Addresses](#)

## 7.2 BMC Interface

The system supports a Baseboard Management Controller (BMC) interface. It provides remote access, monitoring and management. There are several BIOS settings related to the BMC.

For general documentation and information on BMC, please visit our website at: [https://www.supermicro.com/manuals/other/BMC\\_IPMI\\_X13\\_H13.pdf](https://www.supermicro.com/manuals/other/BMC_IPMI_X13_H13.pdf).

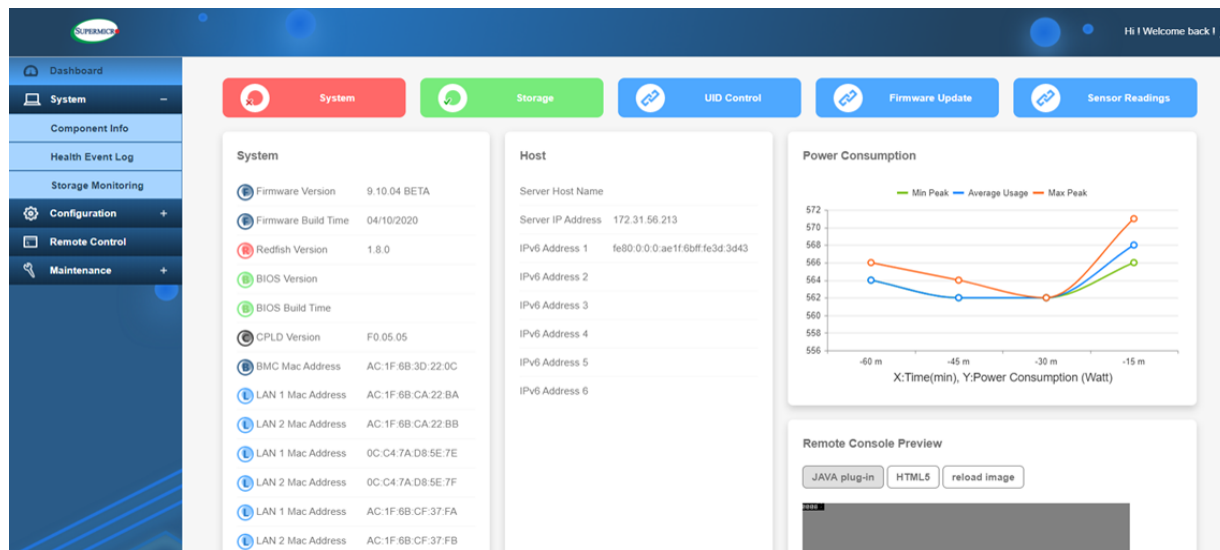


Figure 7-2. BMC Dashboard

## 7.3 Troubleshooting Procedures

Use the following procedures to troubleshoot your system. If you have followed all of the procedures below and still need assistance, refer to the [Technical Support Procedures](#) or [Returning Merchandise for Service](#) section(s) in this chapter. **Power down** the system before changing any non hot-swap hardware components.

### Before Power On

1. Make sure that there are no short circuits between the motherboard and the chassis.
2. Disconnect all ribbon/wire cables from the motherboard, including those for the keyboard and mouse.
3. Remove all add-on cards.
4. Install the CPU (making sure it is fully seated) and connect the front panel connectors to the motherboard.

### No Power

1. Make sure that there are no short circuits between the motherboard and the chassis.
2. The battery on your motherboard may be old. Check to verify that it still supplies approximately 3 VDC. If it does not, replace it with a new one.

### No Video

1. If the power is on, but you do not have video, remove all add-on cards and cables.
2. Remove all memory modules and turn on the system (if the alarm is on, check the specs of memory modules, reset the memory, or try a different one).

### System Boot Failure

If the system does not display POST (Power-On-Self-Test) or does not respond after the power is turned on, check the following:

1. Remove all components from the motherboard, especially the DIMM modules. Power on the system and check if the power-on LED (LED2) and the BMC Heartbeat LED (LEDM1) are on, and system fans are spinning.
2. Turn on the system with only one DIMM module installed. If the system boots, check for bad DIMM modules or slots by following the Memory Errors Troubleshooting procedure in this chapter.

## Memory Errors

1. Make sure that the memory modules are compatible with the system and are properly installed. See [Chapter 2](#) for installation instructions. (For memory compatibility, refer to the "Tested Memory List" link on the motherboard's product page to see a list of supported memory.)
2. Check if different speeds of DIMMs have been installed. It is strongly recommended that you use the same RAM type and speed for all DIMM modules in the system.
3. Make sure that you are using the correct type of ECC DDR5 modules recommended by the manufacturer.
4. Check for bad DIMM modules or slots by swapping a single module among all memory slots and check the results.

## Losing the System's Setup Configuration

1. Make sure that you are using a high-quality power supply. A poor-quality power supply may cause the system to lose the CMOS setup information. Refer to [Chapter 1](#) for details on recommended power supplies.
2. The battery on your motherboard may be old. Check to verify that it still supplies approximately 3 VDC. If it does not, replace it with a new one.

## When the System Becomes Unstable

### ***A. If the system becomes unstable during or after OS installation, check the following:***

1. CPU/BIOS support: Make sure that your CPU is supported and that you have the latest BIOS installed in your system.
2. Memory: Make sure that the memory modules are supported. Refer to the product page on our website at [www.supermicro.com](http://www.supermicro.com). Test the modules using memtest86 or a similar utility.

**Note:** Click on the "Tested Memory List" link on the motherboard's product page to see a list of supported memory.

3. Storage Drive support: Make sure that all storage drives work properly. Replace the failed storage drives with good ones.
4. System cooling: Check the system cooling to make sure that all heatsink fans and CPU/system fans, etc., work properly. Check the hardware monitoring settings in the BMC to make sure that the CPU and system temperatures are within the normal range. Also, check the front panel Overheat LED and make sure that it is not on.

5. Adequate power supply: Make sure that the power supply provides adequate power to the system. Make sure that all power connectors are connected. Please refer to our website for more information on the minimum power requirements.
6. Proper software support: Make sure that the correct drivers are used.

***B. If the system becomes unstable before or during OS installation, check the following:***

1. Source of installation: Make sure that the devices used for installation are working properly, including boot devices such as CD/Media drive.
2. Cable connection: Check to make sure that all cables are connected and working properly.
3. Using the minimum configuration for troubleshooting: Remove all unnecessary components (starting with add-on cards first), and use the minimum configuration (but with a CPU and a memory module installed) to identify the trouble areas. Refer to the steps listed in [Section 7.3](#) above for proper troubleshooting procedures.
4. Identifying bad components by isolating them. If necessary, remove a component in question from the chassis, and test it in isolation to make sure that it works properly. Replace a bad component with a good one.
5. Check and change one component at a time instead of changing several items at the same time. This will help isolate and identify the problem.
6. To find out if a component is good, swap this component with a new one to see if the system will work properly. If so, then the old component is bad. You can also install the component in question in another system. If the new system works, the component is good and the old system has problems.

## 7.4 CMOS Clear

JBT1 is used to clear CMOS, which will also clear any passwords. Instead of pins, this jumper consists of contact pads to prevent accidentally clearing the contents of CMOS.

### ***To Clear CMOS***

1. First **power down** the system and unplug the power cord(s).
2. **Remove the cover** of the chassis to access the motherboard and remove the battery from the motherboard.
3. Short the CMOS pads, JBT1, with a metal object such as a small screwdriver for at least four seconds.
4. Remove the screwdriver (or shorting device).
5. Replace the cover, reconnect the power cord(s), and power on the system.

**Note 1:** Clearing CMOS will also clear all passwords.

**Note 2:** Do not use the PW\_ON connector to clear CMOS.

## 7.5 Where to Get Replacement Components

If you need replacement parts for your system, to ensure the highest level of professional service and technical support, purchase exclusively from our Supermicro Authorized Distributors/System Integrators/Resellers. A list can be found at: <http://www.supermicro.com/>. Click the "Where to Buy" tab.

## 7.6 Technical Support Procedures

Before contacting Technical Support, please take the following steps. Also, please note that as a motherboard manufacturer, Supermicro also sells motherboards through its channels, so it is best to first check with your distributor or reseller for troubleshooting services. They should know of any possible problems with the specific system configuration that was sold to you.

1. Please go through the Troubleshooting Procedures and Frequently Asked Questions (FAQ) sections in this chapter or see the FAQs on our website (<http://www.supermicro.com/FAQ/index.php>) before contacting Technical Support.
2. BIOS upgrades can be downloaded from our website ([http://www.supermicro.com/ResourceApps/BIOS\\_BMC\\_Intel.html](http://www.supermicro.com/ResourceApps/BIOS_BMC_Intel.html)).
3. If you still cannot resolve the problem, include the following information when contacting Supermicro for technical support:
  - Motherboard model and PCB revision number
  - BIOS release date/version (This can be seen on the initial display when your system first boots up.)
  - System configuration
4. An example of a Technical Support form is on our website at <http://www.supermicro.com/RmaForm/>.
5. Distributors: For immediate assistance, please have your account number ready when placing a call to our Technical Support department. We can be reached by email at [support@supermicro.com](mailto:support@supermicro.com).



## Returning Merchandise for Service

A receipt or copy of your invoice marked with the date of purchase is required before any warranty service will be rendered. You can obtain service by calling your vendor for a Returned Merchandise Authorization (RMA) number. When returning to the manufacturer, the RMA number should be prominently displayed on the outside of the shipping carton, and mailed prepaid or hand-carried. Shipping and handling charges will be applied for all orders that must be mailed when service is complete.

For faster service, RMA authorizations may be requested online (<http://www.supermicro.com/support/rma/>).

This warranty only covers normal consumer use and does not cover damages incurred in shipping or from failure due to the alternation, misuse, abuse or improper maintenance of products.

During the warranty period, contact your distributor first for any product problems.

## 7.7 BIOS POST Codes

The AMI BIOS supplies additional checkpoint codes, which are documented online at <http://www.supermicro.com/support/manuals/> ("AMI BIOS POST Codes User's Guide").

For information on AMI updates, please refer to <http://www.ami.com/products/>.

## 7.8 Feedback

Supermicro values your feedback as we strive to improve our customer experience in all facets of our business. To provide feedback on our manuals, please email us at [techwriterteam@supermicro.com](mailto:techwriterteam@supermicro.com).

## 7.9 Contacting Supermicro

### Headquarters

Address: Super Micro Computer, Inc.  
980 Rock Ave.  
San Jose, CA 95131 U.S.A.

Tel: +1 (408) 503-8000

Fax: +1 (408) 503-8008

Email: [marketing@supermicro.com](mailto:marketing@supermicro.com) (General Information)  
[Sales-USA@supermicro.com](mailto:Sales-USA@supermicro.com) (Sales Inquiries)  
[Government\\_Sales-USA@supermicro.com](mailto:Government_Sales-USA@supermicro.com) (Gov. Sales Inquiries)  
[support@supermicro.com](mailto:support@supermicro.com) (Technical Support)  
[RMA@supermicro.com](mailto:RMA@supermicro.com) (RMA Support)  
[Webmaster@supermicro.com](mailto:Webmaster@supermicro.com) (Webmaster)

Website: [www.supermicro.com](http://www.supermicro.com)

### Europe

Address: Super Micro Computer B.V.  
Het Sterrenbeeld 28, 5215 ML  
's-Hertogenbosch, The Netherlands

Tel: +31 (0) 73-6400390

Fax: +31 (0) 73-6416525

Email: [Sales\\_Europe@supermicro.com](mailto:Sales_Europe@supermicro.com) (Sales Inquiries)  
[Support\\_Europe@supermicro.com](mailto:Support_Europe@supermicro.com) (Technical Support)  
[RMA\\_Europe@supermicro.com](mailto:RMA_Europe@supermicro.com) (RMA Support)

Website: [www.supermicro.nl](http://www.supermicro.nl)

### Asia-Pacific

Address: Super Micro Computer, Inc.  
3F, No. 150, Jian 1st Rd.  
Zhonghe Dist., New Taipei City 235  
Taiwan (R.O.C)

Tel: +886-(2) 8226-3990

Fax: +886-(2) 8226-3992

Email: [Sales-Asia@supermicro.com.tw](mailto:Sales-Asia@supermicro.com.tw) (Sales Inquiries)  
[Support@supermicro.com.tw](mailto:Support@supermicro.com.tw) (Technical Support)  
[RMA@supermicro.com.tw](mailto:RMA@supermicro.com.tw) (RMA Support)

Website: [www.supermicro.com.tw](http://www.supermicro.com.tw)

## Appendix A

# Standardized Warning Statements for AC Systems

### About Standardized Warning Statements

The following statements are industry standard warnings, provided to warn the user of situations which have the potential for bodily injury. Should you have questions or experience difficulty, contact Supermicro's Technical Support department for assistance. Only certified technicians should attempt to install or configure components.

Read this appendix in its entirety before installing or configuring components in the Supermicro chassis.

These warnings may also be found on our website at [http://www.supermicro.com/about/policies/safety\\_information.cfm](http://www.supermicro.com/about/policies/safety_information.cfm).

### Warning Definition



**Warning!** This warning symbol means danger. You are in a situation that could cause bodily injury. Before you work on any equipment, be aware of the hazards involved with electrical circuitry and be familiar with standard practices for preventing accidents.

#### 警告の定義

この警告サインは危険を意味します。

人身事故につながる可能性がありますので、いずれの機器でも動作させる前に、電気回路に含まれる危険性に注意して、標準的な事故防止策に精通して下さい。

此警告符号代表危險。

您正处于可能受到严重伤害的工作环境中。在您使用设备开始工作之前，必须充分意识到触电的危险，并熟练掌握防止事故发生的标准工作程序。请根据每项警告结尾的声明号码找到此设备的安全性警告说明的翻译文本。

此警告符號代表危險。

您正處於可能身體可能會受損傷的工作環境中。在您使用任何設備之前，請注意觸電的危險，並且要熟悉預防事故發生的標準工作程序。請依照每一注意事項後的號碼找到相關的翻譯說明內容。

## Warnung

### WICHTIGE SICHERHEITSHINWEISE

Dieses Warnsymbol bedeutet Gefahr. Sie befinden sich in einer Situation, die zu Verletzungen führen kann. Machen Sie sich vor der Arbeit mit Geräten mit den Gefahren elektrischer Schaltungen und den üblichen Verfahren zur Vorbeugung vor Unfällen vertraut. Suchen Sie mit der am Ende jeder Warnung angegebenen Anweisungsnummer nach der jeweiligen Übersetzung in den übersetzten Sicherheitshinweisen, die zusammen mit diesem Gerät ausgeliefert wurden.

BEWAHREN SIE DIESE HINWEISE GUT AUF.

### INSTRUCCIONES IMPORTANTES DE SEGURIDAD

Este símbolo de aviso indica peligro. Existe riesgo para su integridad física. Antes de manipular cualquier equipo, considere los riesgos de la corriente eléctrica y familiarícese con los procedimientos estándar de prevención de accidentes. Al final de cada advertencia encontrará el número que le ayudará a encontrar el texto traducido en el apartado de traducciones que acompaña a este dispositivo.

GUARDE ESTAS INSTRUCCIONES.

### IMPORTANTES INFORMATIONS DE SÉCURITÉ

Ce symbole d'avertissement indique un danger. Vous vous trouvez dans une situation pouvant entraîner des blessures ou des dommages corporels. Avant de travailler sur un équipement, soyez conscient des dangers liés aux circuits électriques et familiarisez-vous avec les procédures couramment utilisées pour éviter les accidents. Pour prendre connaissance des traductions des avertissements figurant dans les consignes de sécurité traduites qui accompagnent cet appareil, référez-vous au numéro de l'instruction situé à la fin de chaque avertissement.

CONSERVEZ CES INFORMATIONS.

## תקנון הזהרות אזהרה

הזהרות הבאות הן אזהרות על פי תקני התעשייה, על מנת להזהיר את המשתמש מפני חבלה פיזית אפשרית. במידה ויש שאלות או היתקלות בבעיה כלשהי, יש ליצור קשר עם מחלקת תמיכה טכנית של סופרמיקרו. טכנאים מוסמכים בלבד רשאים להתקין או להגדיר את הרכיבים. יש לקרוא את הנספח במלואו לפני התקנת או הגדרת הרכיבים במארזי סופרמיקרו.

اَكْ ف حالة وُكِي اَي تتسبب ف اصابة جسدهُ هذا الزهز عُ خطر! تحذُرُ .  
 قبل اَي تعول على اَي هعدات، كي على علن بالوخاطز ال اُجوة عي الذوائر  
 الكهزبائِة  
 وكي على دراةُ بالووارسات النقااِة لو عُ وقع اَي حادث  
 استخدم رقن الب اِى الو صُص ف هَّاةُ كل تحذُرُ للعشر تزجوتها

안전을 위한 주의사항

경고!

이 경고 기호는 위험이 있음을 알려 줍니다. 작업자의 신체에 부상을 야기 할 수 있는 상태에 있게 됩니다. 모든 장비에 대한 작업을 수행하기 전에 전기회로와 관련된 위험요소들을 확인하시고 사전에 사고를 방지할 수 있도록 표준 작업절차를 준수해 주시기 바랍니다.

해당 번역문을 찾기 위해 각 경고의 마지막 부분에 제공된 경고문 번호를 참조하십시오

## BELANGRIJKE VEILIGHEIDSINSTRUCTIES

Dit waarschuwings symbool betekent gevaar. U verkeert in een situatie die lichamelijk letsel kan veroorzaken. Voordat u aan enige apparatuur gaat werken, dient u zich bewust te zijn van de bij een elektrische installatie betrokken risico's en dient u op de hoogte te zijn van de standaard procedures om ongelukken te voorkomen. Gebruik de nummers aan het eind van elke waarschuwing om deze te herleiden naar de desbetreffende locatie.

BEWAAR DEZE INSTRUCTIES

## Installation Instructions



**Warning!** Read the installation instructions before connecting the system to the power source.

設置手順書

システムを電源に接続する前に、設置手順書をお読み下さい。

警告

将此系统连接电源前,请先阅读安装说明。

警告

將系統與電源連接前，請先閱讀安裝說明。

**Warnung**

Vor dem Anschließen des Systems an die Stromquelle die Installationsanweisungen lesen.

**¡Advertencia!**

Lea las instrucciones de instalación antes de conectar el sistema a la red de alimentación.

**Attention**

Avant de brancher le système sur la source d'alimentation, consulter les directives d'installation.

יש לקרוא את הוראות התקנה לפני חיבור המערכת למקור מתח.

اقر إرشادات التركيب قبل توصيل النظام إلى مصدر للطاقة

시스템을 전원에 연결하기 전에 설치 안내를 읽어주십시오.

**Waarschuwing**

Raadpleeg de installatie-instructies voordat u het systeem op de voedingsbron aansluit.

**Circuit Breaker**

**Warning!** This product relies on the building's installation for short-circuit (overcurrent) protection. Ensure that the protective device is rated not greater than: 250 V, 20 A.

**サーキット・ブレーカー**

この製品は、短絡(過電流)保護装置がある建物での設置を前提としています。

保護装置の定格が250 V、20 Aを超えないことを確認下さい。

**警告**

此产品的短路(过载电流)保护由建筑物的供电系统提供,确保短路保护设备的额定电流不大于250V,20A。

**警告**

此產品的短路(過載電流)保護由建築物的供電系統提供,確保短路保護設備的額定電流不大於250V,20A。

**Warnung**

Dieses Produkt ist darauf angewiesen, dass im Gebäude ein Kurzschluss- bzw. Überstromschutz installiert ist. Stellen Sie sicher, dass der Nennwert der Schutzvorrichtung nicht mehr als: 250 V, 20 A beträgt.

**¡Advertencia!**

Este equipo utiliza el sistema de protección contra cortocircuitos (o sobrecorrientes) del edificio. Asegúrese de que el dispositivo de protección no sea superior a: 250 V, 20 A.

**Attention**

Pour ce qui est de la protection contre les courts-circuits (surtension), ce produit dépend de l'installation électrique du local. Vérifiez que le courant nominal du dispositif de protection n'est pas supérieur à :250 V, 20 A.

מוצר זה מסתמך על הגנה המותקנת במבנים למניעת קצר חשמלי. יש לוודא כי המכשיר המגן מפני הקצר החשמלי הוא לא יותר מ-250VDC, 20A

هذا المنتج يعتمد على معدات الحماية من الدوائر القصيرة التي تم تثبيتها في المبنى  
تأكد من أن تقييم الجهاز الوقائي ليس أكثر من : 20A, 250V

**경고!**

이 제품은 전원의 단락(과전류)방지에 대해서 전적으로 건물의 관련 설비에 의존합니다. 보호장치의 정격이 반드시 250V(볼트), 20A(암페어)를 초과하지 않도록 해야 합니다.

**Waarschuwing**

Dit product is afhankelijk van de kortsluitbeveiliging (overspanning) van uw elektrische installatie. Controleer of het beveiligde apparaat niet groter gedimensioneerd is dan 250V, 20A.

## Power Disconnection Warning



**Warning!** The system must be disconnected from all sources of power and the power cord removed from the power supply module(s) before accessing the chassis interior to install or remove system components (except for hot-swap components).



### 電源切断の警告

システムコンポーネントの取り付けまたは取り外しのために、シャーシ内部にアクセスするには、システムの電源はすべてのソースから切断され、電源コードは電源モジュールから取り外す必要があります。

### 警告

在你打开机箱并安装或移除内部器件前,必须将系统完全断电,并移除电源线。

### 警告

在您打開機殼安裝或移除內部元件前，必須將系統完全斷電，並移除電源線。

### Warnung

Das System muss von allen Quellen der Energie und vom Netzanschlusskabel getrennt sein, das von den Spg.Versorgungsteilmodulen entfernt wird, bevor es auf den Chassisinnenraum zurückgreift, um Systemsbestandteile anzubringen oder zu entfernen.

### ¡Advertencia!

El sistema debe ser disconnected de todas las fuentes de energía y del cable eléctrico quitado de los módulos de fuente de alimentación antes de tener acceso el interior del chasis para instalar o para quitar componentes de sistema.

### Attention

Le système doit être débranché de toutes les sources de puissance ainsi que de son cordon d'alimentation secteur avant d'accéder à l'intérieur du chassis pour installer ou enlever des composants de système.



אזהרה מפני ניתוק חשמלי

אזהרה!

יש לנתק את המערכת מכל מקורות החשמל ויש להסיר את כבל החשמלי מהספק לפני גישה לחלק הפנימי של המארז לצורך התקנת או הסרת רכיבים.

يجب فصل انظاؤ من جميع مصادر انطاقت وإزانت سهك انكهرباء من وحدة امداد انطاقت قيم

انصل إلى امناطق انداخييت نههيكم نشييج أو إزانت مكنناث الجهاز

경고!

시스템에 부품들을 장착하거나 제거하기 위해서는 새시 내부에 접근하기 전에 반드시 전원 공급장치로부터 연결되어있는 모든 전원과 전기코드를 분리해주어야 합니다.

Waarschuwing

Voordat u toegang neemt tot het binnenwerk van de behuizing voor het installeren of verwijderen van systeem onderdelen, dient u alle spanningsbronnen en alle stroomkabels aangesloten op de voeding(en) van de behuizing te verwijderen

## Equipment Installation



**Warning!** Only authorized personnel and qualified service persons should be allowed to install, replace, or service this equipment.

機器の設置

トレーニングを受け認定された人だけがこの装置の設置、交換、またはサービスを許可されています。

警告

只有经过培训且具有资格的人员才能进行此设备的安装、更换和维修。

警告

只有經過受訓且具資格人員才可安裝、更換與維修此設備。

Warnung

Nur autorisiertes Personal und qualifizierte Servicetechniker dürfen dieses Gerät installieren, austauschen oder warten..

¡Advertencia!

Sólo el personal autorizado y el personal de servicio calificado deben poder instalar, reemplazar o dar servicio a este equipo.

**Attention**

Seul le personnel autorisé et le personnel de maintenance qualifié doivent être autorisés à installer, remplacer ou entretenir cet équipement..

אזהרה!

יש לאפשר רק צוות מורשה ואנשי שירות מוסמכים להתקין, להחליף או לטפל בציוד זה.

ينبغي السماح فقط للموظفين المعتمدين وأفراد الخدمة المؤهلين بتركيب هذا الجهاز أو استبداله أو صيانته.

**경고!**

승인된 직원과 자격을 갖춘 서비스 담당자만이 이 장비를 설치, 교체 또는 서비스할 수 있습니다.

**Waarschuwing**

Alleen geautoriseerd personeel en gekwalificeerd onderhoudspersoneel mag deze apparatuur installeren, vervangen of onderhouden..

**Restricted Area**

**Warning!** This unit is intended for installation in restricted access areas. A restricted access area can be accessed only through the use of a special tool, lock and key, or other means of security. (This warning does not apply to workstations).

**アクセス制限区域**

このユニットは、アクセス制限区域に設置されることを想定しています。

アクセス制限区域は、特別なツール、鍵と錠前、その他のセキュリティの手段を用いてのみ出入りが可能です。

**警告**

此部件应安装在限制进出的场所，限制进出的场所指只能通过使用特殊工具、锁和钥匙或其它安全手段进出的场所。

**警告**

此裝置僅限安裝於進出管制區域，進出管制區域係指僅能以特殊工具、鎖頭及鑰匙或其他安全方式才能進入的區域。

**Warnung**

Diese Einheit ist zur Installation in Bereichen mit beschränktem Zutritt vorgesehen. Der Zutritt zu derartigen Bereichen ist nur mit einem Spezialwerkzeug, Schloss und Schlüssel oder einer sonstigen Sicherheitsvorkehrung möglich.

**¡Advertencia!**

Esta unidad ha sido diseñada para instalación en áreas de acceso restringido. Sólo puede obtenerse acceso a una de estas áreas mediante la utilización de una herramienta especial, cerradura con llave u otro medio de seguridad.

**Attention**

Cet appareil doit être installée dans des zones d'accès réservés. L'accès à une zone d'accès réservé n'est possible qu'en utilisant un outil spécial, un mécanisme de verrouillage et une clé, ou tout autre moyen de sécurité.

אזור עם גישה מוגבלת

אזהרה!

יש להתקין את היחידה באזורים שיש בהם הגבלת גישה. הגישה ניתנת בעזרת 'כלי אבטחה בלבד' (מפתח, מנעול וכד.).

تخصيص هذه انحدة نترك بها ف مناطق محظورة تم .  
ممكن انصلل إن منطقت محظورة فقط من خلال استخذاو أداة خاصت  
أو أ وس هُت أخري نلالأمما ققم ومفتاح

**경고!**

이 장치는 접근이 제한된 구역에 설치하도록 되어있습니다. 특수도구, 잠금 장치 및 키, 또는 기타 보안 수단을 통해서만 접근 제한 구역에 들어갈 수 있습니다.

**Waarschuwing**

Dit apparaat is bedoeld voor installatie in gebieden met een beperkte toegang. Toegang tot dergelijke gebieden kunnen alleen verkregen worden door gebruik te maken van speciaal gereedschap, slot en sleutel of andere veiligheidsmaatregelen.

## Battery Handling



**CAUTION:** There is risk of explosion if the battery is replaced by an incorrect type. Replace the battery only with the same or equivalent type recommended by the manufacturer. Dispose of used batteries according to the manufacturer's instructions

### 電池の取り扱い

バッテリーを間違ったタイプに交換すると爆発の危険があります。交換する電池はメーカーが推奨する型、または同等のものを使用下さい。使用済電池は製造元の指示に従って処分して下さい。

### 警告

如果更换的电池类型不正确，则存在爆炸危险。请只使用同类电池或制造商推荐的功能相当的电池更换原有电池。请按制造商的说明处理废旧电池。

### 警告

如果更換的電池類型不正確，則有爆炸危險。請使用製造商建議之相同或功能相當的電池更換原有電池。請按照製造商的說明指示處理廢棄舊電池。

### WARNUNG

Es besteht Explosionsgefahr, wenn die Batterie durch einen falschen Typ ersetzt wird. Ersetzen Sie die Batterie nur durch den gleichen oder vom Hersteller empfohlenen Batterietyp. Entsorgen Sie die benutzten Batterien nach den Anweisungen des Herstellers.

### ATTENTION

Il existe un risque d'explosion si la batterie est remplacée par un type incorrect. Ne la remplacer que par une pile de type semblable ou équivalent, recommandée par le fabricant. Jeter les piles usagées conformément aux instructions du fabricant.

### ADVERTENCIA

Existe riesgo de explosión si la batería se reemplaza por un tipo incorrecto. Reemplazar la batería exclusivamente con el mismo tipo o el equivalente recomendado por el fabricante. Desechar las baterías gastadas según las instrucciones del fabricante.

אזהרה!

קיימת סכנת פיצוץ אם הסוללה תוחלף בסוג שגוי. יש להחליף את הסוללה בסוג התואם מחברת יצרן מומלצת. סילוק הסוללות המשומשות יש לבצע לפי הוראות היצרן.

هناك خطر الانفجار إذا تم استبدال البطارية بنوع غير صحيح.  
 اسحبذال البطارية  
 فقط بنفس النوع أو ما يعادلها مما أوصت به الشركة المصنعة  
 جخلص من البطاريات المسحمة وفقا لعمليات الشركة الصانعة

경고!

배터리를 잘못된 종류로 교체하면 폭발의 위험이 있습니다. 기존 배터리와 동일하거나 제조사에서 권장하는 동등한 종류의 배터리로만 교체해야 합니다. 제조사의 안내에 따라 사용된 배터리를 처리하여 주십시오.

#### WAARSCHUWING

Er bestaat explosiegevaar als de batterij wordt vervangen door een verkeerd type. Vervang de batterij slechts met hetzelfde of een equivalent type die door de fabrikant aanbevolen wordt. Gebruikte batterijen dienen overeenkomstig fabrieksvoorschriften afgevoerd te worden.

### Redundant Power Supplies



**Warning!** This unit might have more than one power supply connection. All connections must be removed to de-energize the unit.

冗長電源装置

このユニットは複数の電源装置が接続されている場合があります。

ユニットの電源を切るためには、すべての接続を取り外さなければなりません。

警告

此部件连接的电源可能不止一个，必须将所有电源断开才能停止给该部件供电。

警告

此装置连接的电源可能不只一个，必须切断所有电源才能停止对该装置的供电。

Warnung

Dieses Gerät kann mehr als eine Stromzufuhr haben. Um sicherzustellen, dass der Einheit kein Strom zugeführt wird, müssen alle Verbindungen entfernt werden.

## ¡Advertencia!

Puede que esta unidad tenga más de una conexión para fuentes de alimentación. Para cortar por completo el suministro de energía, deben desconectarse todas las conexiones.

## Attention

Cette unité peut avoir plus d'une connexion d'alimentation. Pour supprimer toute tension et tout courant électrique de l'unité, toutes les connexions d'alimentation doivent être débranchées.

אם קיים יותר מספק אחד

אזהרה!

ליחידה יש יותר מחיבור אחד של ספק. יש להסיר את כל החיבורים על מנת לרוקן את היחידה.

قد يكون لهذا الجهاز عدة اتصالات بوحدات امداد الطاقة .

يجب إزالة كافة الاتصالات لعسل الوحدة عن الكهرباء

## 경고!

이 장치에는 한 개 이상의 전원 공급 단자가 연결되어 있을 수 있습니다. 이 장치에 전원을 차단하기 위해서는 모든 연결 단자를 제거해야만 합니다.

## Waarschuwing

Deze eenheid kan meer dan één stroomtoevoeraansluiting bevatten. Alle aansluitingen dienen verwijderd te worden om het apparaat stroomloos te maken.

## Backplane Voltage



**Warning!** Hazardous voltage or energy is present on the backplane when the system is operating. Use caution when servicing.

バックプレーンの電圧

システムの稼働中は危険な電圧または電力が、バックプレーン上にかかっています。

修理する際には注意ください。

警告

当系统正在进行时，背板上有很危险的电压或能量，进行维修时务必小心。

警告

當系統正在進行時，背板上危險的電壓或能量，進行維修時務必小心。

Warnung

Wenn das System in Betrieb ist, treten auf der Rückwandplatine gefährliche Spannungen oder Energien auf. Vorsicht bei der Wartung.

¡Advertencia!

Cuando el sistema está en funcionamiento, el voltaje del plano trasero es peligroso. Tenga cuidado cuando lo revise.

Attention

Lorsque le système est en fonctionnement, des tensions électriques circulent sur le fond de panier. Prendre des précautions lors de la maintenance.

מתח בפנל האחורי

אזהרה!

קיימת סכנת מתח בפנל האחורי בזמן תפעול המערכת. יש להיזהר במהלך העבודה.

هناك خطر من التيار الكهربائي أو الطاقة المتجددة على اللوحة  
عندما يكون النظام يعمل كه حذرا عند خدمة هذا الجهاز

경고!

시스템이 동작 중일 때 후면판 (Backplane)에는 위험한 전압이나 에너지가 발생 합니다.  
서비스 작업 시 주의하십시오.

Waarschuwing

Een gevaarlijke spanning of energie is aanwezig op de backplane wanneer het systeem in gebruik is. Voorzichtigheid is geboden tijdens het onderhoud.

## Comply with Local and National Electrical Codes



**Warning!** Installation of the equipment must comply with local and national electrical codes.

地方および国の電気規格に準拠

機器の取り付けはその地方および国の電気規格に準拠する必要があります。

警告

设备安装必须符合本地与本国电气法规。

警告

設備安裝必須符合本地與本國電氣法規。

Warnung

Die Installation der Geräte muss den Sicherheitsstandards entsprechen.

¡Advertencia!

La instalación del equipo debe cumplir con las normas de electricidad locales y nacionales.

Attention

L'équipement doit être installé conformément aux normes électriques nationales et locales.



תיאום חוקי החשמל הארצי  
אזהרה!  
התקנת הציוד חייבת להיות תואמת לחוקי החשמל המקומיים והארציים.

تركيب المعدات الكهربائية يجب أن يمتثل للقوايه المحلية والبطية المتعلقة  
بالكهرباء

경고!

현 지역 및 국가의 전기 규정에 따라 장비를 설치해야 합니다.

Waarschuwing

Bij installatie van de apparatuur moet worden voldaan aan de lokale en nationale elektriciteitsvoorschriften.

## Product Disposal



**Warning!** Ultimate disposal of this product should be handled according to all national laws and regulations.

製品の廃棄

この製品を廃棄処分する場合、国の関係する全ての法律・条例に従い処理する必要があります。

警告

本产品的废弃处理应根据所有国家的法律和规章进行。

警告

本產品的廢棄處理應根據所有國家的法律和規章進行。

Warnung

Die Entsorgung dieses Produkts sollte gemäß allen Bestimmungen und Gesetzen des Landes erfolgen.

¡Advertencia!

Al deshacerse por completo de este producto debe seguir todas las leyes y reglamentos nacionales.

## Attention

La mise au rebut ou le recyclage de ce produit sont généralement soumis à des lois et/ou directives de respect de l'environnement. Renseignez-vous auprès de l'organisme compétent.

סילוק המוצר

אזהרה!

סילוק סופי של מוצר זה חייב להיות בהתאם להנחיות וחוקי המדינה.

التخلص النهائي من هذا المنتج ينبغي التعامل معه وفقا لجميع القوانين واللوائح الوطنية عند

경고!

이 제품은 해당 국가의 관련 법규 및 규정에 따라 폐기되어야 합니다.

## Waarschuwing

De uiteindelijke verwijdering van dit product dient te geschieden in overeenstemming met alle nationale wetten en reglementen.

## Fan Warning



**Warning!** Hazardous moving parts. Keep away from moving fan blades. The fans might still be turning when you remove the fan assembly from the chassis. Keep fingers, screwdrivers, and other objects away from the openings in the fan assembly's housing.

ファンの警告

警告!回転部品に注意。運転中は回転部(羽根)に触れないでください。シャーシから冷却ファン装置を取り外した際、ファンがまだ回転している可能性があります。ファンの開口部に、指、ドライバー、およびその他のものを近づけないで下さい。

警告!

警告! 危險的可移動性零件。請務必與轉動的风扇叶片保持距離。當您從機架移除風扇裝置，風扇可能仍在轉動。小心不要將手指、螺絲起子和其他物品太靠近風扇

警告

危險的可移動性零件。請務必與轉動的风扇叶片保持距離。當您從機架移除風扇裝置，風扇可能仍在轉動。小心不要將手指、螺絲起子和其他物品太靠近風扇。

**Warnung**

Gefährlich Bewegende Teile. Von den bewegenden Lüfterblätter fern halten. Die Lüfter drehen sich u. U. noch, wenn die Lüfterbaugruppe aus dem Chassis genommen wird. Halten Sie Finger, Schraubendreher und andere Gegenstände von den Öffnungen des Lüftergehäuses entfernt.

**¡Advertencia!**

Riesgo de piezas móviles. Mantener alejado de las aspas del ventilador. Los ventiladores podran dar vuelta cuando usted quite el montaje del ventilador del chasis. Mantenga los dedos, los destornilladores y todos los objetos lejos de las aberturas del ventilador

**Attention**

Pieces mobiles dangereuses. Se tenir a l'écart des lames du ventilateur Il est possible que les ventilateurs soient toujours en rotation lorsque vous retirerez le bloc ventilateur du châssis. Prenez garde à ce que doigts, tournevis et autres objets soient éloignés du logement du bloc ventilateur.

**אזהרה!**

חלקים נעים מסוכנים. התרחק מלהבי המאוורר בפעולה כאשר מסירים את חלקי המאוורר מהמארז, יתכן והמאווררים עדיין עובדים. יש להרחיק למרחק בטוח את האצבעות וכלי עבודה שונים מהפתחים בתוך המאוורר

تحذير! أجزاء متحركة خطيرة. ابتعد عن شفرات المروحة المتحركة. من الممكن أن المراوح لا تزال تدور عند إزالة كتلة المروحة من الهيكل يجب إبقاء الأصابع ومفكات البراغي وغيرها من الأشياء بعيدا عن الفتحات في كتلة المروحة

**경고!**

움직이는 위험한 부품. 회전하는 송풍 날개에 접근하지 마세요. 새시로부터 팬 조립품을 제거할 때 팬은 여전히 회전하고 있을 수 있습니다. 팬 조립품 외관의 열려있는 부분들로부터 손가락 및 스크류드라이버, 다른 물체들이 가까이 하지 않도록 배치해 주십시오.

**Waarschuwing**

Gevaarlijk bewegende onderdelen. Houd voldoende afstand tot de bewegende ventilatorbladen. Het is mogelijk dat de ventilator nog draait tijdens het verwijderen van het ventilatorsamenstel uit het chassis. Houd uw vingers, schroevendraaiers en eventuele andere voorwerpen uit de buurt van de openingen in de ventilatorbehuizing.

## Power Cable and AC Adapter



**Warning!** When installing the product, use the provided or designated connection cables, power cables and AC adapters. Using any other cables and adapters could cause a malfunction or a fire. Electrical Appliance and Material Safety Law prohibits the use of UL or CSA -certified cables (that have UL/CSA shown on the cord) for any other electrical devices than products designated by Supermicro only.

### 電源コードとACアダプター

製品を設置する場合、提供または指定および購入された接続ケーブル、電源コードとACアダプターを該当する地域の条例や安全基準に適合するコードサイズやプラグと共に使用下さい。他のケーブルやアダプタを使用すると故障や火災の原因になることがあります。

電気用品安全法は、ULまたはCSA認定のケーブル(UL/CSAマークがコードに表記)を Supermicro が指定する製品以外に使用することを禁止しています。

### 警告

安装此产品时,请使用本身提供的或指定的或采购的连接线,电源线和电源适配器。包含遵照当地法规和安全要求的合规的电源线尺寸和插头。使用其它线材或适配器可能会引起故障或火灾。除了Supermicro所指定的产品,电气用品和材料安全法律规定禁止使用未经UL或CSA认证的线材。(线材上会显示UL/CSA符号)。

### 警告

安裝此產品時,請使用本身提供的或指定的或採購的連接線,電源線和電源適配器。包含遵照當地法規和安全要求的合規的電源線尺寸和插頭。使用其它線材或適配器可能會引起故障或火災。除了Supermicro所指定的產品,電氣用品和材料安全法律規定禁止使用未經UL或CSA認證的線材。(線材上會顯示UL/CSA符號)。

### Warnung

Nutzen Sie beim Installieren des Produkts ausschließlich die von uns zur Verfügung gestellten Verbindungskabeln, Stromkabeln und/oder Adapter, die Ihre örtlichen Sicherheitsstandards einhalten. Der Gebrauch von anderen Kabeln und Adapter können Fehlfunktionen oder Feuer verursachen. Die Richtlinien untersagen das Nutzen von UL oder CAS zertifizierten Kabeln (mit UL/CSA gekennzeichnet), an Geräten oder Produkten die nicht mit Supermicro gekennzeichnet sind.

## ¡Advertencia!

Cuando instale el producto, utilice la conexión provista o designada o procure cables, Cables de alimentación y adaptadores de CA que cumplan con los códigos locales y los requisitos de seguridad, incluyendo el tamaño adecuado del cable y el enchufe. El uso de otros cables y adaptadores podría causar un mal funcionamiento o un incendio. La Ley de Seguridad de Aparatos Eléctricos y de Materiales prohíbe El uso de cables certificados por UL o CSA (que tienen el certificado UL / CSA en el código) para cualquier otros dispositivos eléctricos que los productos designados únicamente por Supermicro.

## Attention

Lors de l'installation du produit, utilisez les cables de connection fournis ou désigné ou achetez des cables, cables de puissance et adaptateurs respectant les normes locales et les conditions de securite y compris les tailles de cables et les prises electriques appropriées. L'utilisation d'autres cables et adaptateurs peut provoquer un dysfonctionnement ou un incendie. Appareils électroménagers et la Loi sur la Sécurité Matériel interdit l'utilisation de câbles certifiés- UL ou CSA (qui ont UL ou CSA indiqué sur le code) pour tous les autres appareils électriques sauf les produits désignés par Supermicro seulement.

AC ימאתמו מיי למשח מילבכ

!הרהזא

ךרוצל ומאתוה וא ושכרנ רשא AC מיימאתמו מיקפס, מילבכב שמתשהל שי, רצומה תא מיניקתמ רשאכ לכב שומיש . עקתהו לבכה לש הנוכח הדימ ללוכ, תוימוקמה תוחיטבה תושירדל ומאתוה רשאו, הנקתהה למשחה ירישכמב שומישה יקוחל מאתהב. ילמשח רצק וא הלקתל מורגל לולע, רחא גוסמ מאתמ וא לבכ לש דוק מהילע עיפומ רשאכ) UL-ב או CSA-ב -ב מיכמומה מילבכב שמתשהל רוסיא מייק, תוחיטבה יקוחו דבלב Supermicro י"ע מאתוה רשא רצומב קר אלא, רחא ילמשח רצומ לכ רובע (UL/CSA)

תאלבאלא אארשב מץ וא אדדחמלא וא ארפוטמלא תאליטוטלא מאדחטסאב מץ, אגתנמלא בייקרת דנע לכלז יפ אמב אילחמלא אמאלסלא תאבלטתמו נינאוץב מאזתלאלא אמ דדרתמלא ראיטלא תאלוחמו אילברמלא קיירח וא לטע יפ בבסטטי דץ ירשא תאלוחמו תאלבאלא יא מאדחטסא. מילסלא סבאלאו לטומוא מץ ח. CSA וא UL לבק נמ אדמטעמלא תאלבאלא מאדחטסא תאדעמלא אילברמלא אזהאלל אמאלסלא נונאק רזחי Supermicro לבק נמ אדדחמלא אילחמלא תאגתנמלא רייג ירשא תאדעמ יא אמ (UL/CSA) אמאלע למחתיטלאו

### 전원 케이블 및 AC 어댑터

경고! 제품을 설치할 때 현지 코드 및 적절한 굵기의 코드와 플러그를 포함한 안전 요구 사항을 준수하여 제공되거나 지정된 연결 혹은 구매 케이블, 전원 케이블 및 AC 어댑터를 사용하십시오.

다른 케이블이나 어댑터를 사용하면 오작동이나 화재가 발생할 수 있습니다. 전기 용품 안전법은 UL 또는 CSA 인증 케이블 (코드에 UL / CSA가 표시된 케이블)을 Supermicro가 지정한 제품 이외의 전기 장치에 사용하는 것을 금지합니다.

### Stroomkabel en AC-Adapter

Waarschuwing! Bij het aansluiten van het Product uitsluitend gebruik maken van de geleverde Kabels of een andere geschikte aan te schaffen Aansluitmethode, deze moet altijd voldoen aan de lokale voorschriften en veiligheidsnormen, inclusief de juiste kabeldikte en stekker. Het gebruik van niet geschikte Kabels en/of Adapters kan een storing of brand veroorzaken. Wetgeving voor Elektrische apparatuur en Materiaalveiligheid verbied het gebruik van UL of CSA -gecertificeerde Kabels (met UL/CSA in de code) voor elke andere toepassing dan de door Supermicro hiervoor beoogde Producten.

# Appendix B

## System Specifications

### Processors

Supports dual 4<sup>th</sup> and 5<sup>th</sup> Gen Intel Xeon Scalable Processors (in Socket E LGA 4677) with four UPIs (20 GT/s max.) and a thermal design power (TDP) up to 350 W  
SP XCC, SP MCC, and Max Series (HBM) SKUs supported

### Chipset

Intel C741 PCH

### BIOS

AMI SPI BIOS

### Memory

Supports up to 8 TB 3DS RDIMM/RDIMM DDR5 ECC memory in 32 DIMM slots

- 4<sup>th</sup> Gen CPU: speeds of up to 4800 MT/s (1DPC) and up to 4400 MT/s (2DPC)

- 5<sup>th</sup> Gen CPU: speeds of up to 5600 MT/s (1DPC) and up to 4400 MT/s (2DPC)

**Note:** Memory speed/capacity support depends on the processors used in the system.)

### Storage Drives

SYS-221H-TNR: eight NVMe/SATA/SAS drive bays (optional configuration for sixteen NVMe/SATA/SAS drive bays)

SYS-221H-TN24R: 24 NVMe/SATA/SAS drive bays

Both systems: two M.2 NVMe or two M.2 SATA3 slots on the motherboard

### PCI Expansion Slots

Eight PCIe 5.0 x16 FH, 10.5" L

### Input/Output

One AIOM (slim) slot with optional configurations for up to two AIOM (slim) slots for flexible networking (OCP 3.0 compatible)

One RJ45 dedicated BMC LAN port

Two USB 2.0 ports (rear)

One VGA port

### Motherboard

X13DEM; 17.0" (W) x 11.5" (L) E-ATX (431.80 mm x 292.1 mm)

### Chassis

CSE-HS219-R1K24P/HS219-R1K63P 2U Rackmount, 1.7" x 17.2" x 29.3" / 43 x 437 x 746 mm (H x W x D)

### System Cooling

Four 8-cm heavy duty hot-swap fans with optimal fan speed control

Two air shrouds

**Power Supply**

Model: PWS-1K24A-1R, 1200 W redundant modules, 80Plus Titanium level

**AC Input**

800 W: 100-127 Vac / 50-60 Hz

1200 W: 200-240 Vac / 50-60 Hz

**+12V**

Max: 83 A (100 Vac-127 Vac)

Max: 166 A (200 Vac-220 Vac)

**12V SB**

Max: 2.1 A / Min: 0 A

Model: PWS-1K63A-1R 1600W redundant modules, 80Plus Titanium level

**AC Input**

1600 W: 200-240 Vac/50-60 Hz

1000 W: 100-127 Vac/50-60 Hz

**+12V**

Max: 83 A (100 Vac-127 Vac)

Max: 133 A (200 Vac-240 Vac)

**12V SB**

Max: 3.5 A / Min: 0 A

**Operating Environment**

Operating Temperature: 10°C to 35°C (50°F to 95°F)

Non-operating Temperature: -40°C to 60°C (-40°F to 140°F)

Operating Relative Humidity: 8% to 90% (non-condensing)

Non-operating Relative Humidity: 5% to 95% (non-condensing)

**Regulatory Compliance**

FCC, ICES, CE, UKCA, VCCI, RCM, NRTL, CB



**Applied Directives, Standards**

EMC/EMI: 2014/30/EU (EMC Directive)  
Electromagnetic Compatibility Regulations 2016  
FCC Part 15 Subpart B  
ICES-003  
VCCI-CISPR 32  
AS/NZS CISPR 32  
BS/EN 55032  
BS/EN 55035  
CISPR 32  
CISPR 24/CISPR 35  
BS/EN 61000-3-2  
BS/EN 61000-3-3  
BS/EN 61000-4-2  
BS/EN 61000-4-3  
BS/EN 61000-4-4  
BS/EN 61000-4-5  
BS/EN 61000-4-6  
BS/EN 61000-4-8  
BS/EN 61000-4-11  
Product Safety: 2014/35/EU (LVD Directive)  
UL/CSA 62368-1 (USA and Canada)  
Electrical Equipment (Safety) Regulations 2016  
IEC/BS/EN 62368-1  
Environment:  
2011/65/EU (RoHS Directive)  
EC 1907/2006 (REACH)  
2012/19/EU (WEEE Directive)  
California Proposition 65  
Warning! This product can expose you to chemicals including lead, known to the State of California to cause cancer and birth defects or other reproductive harm. For more information, go to [www.P65Warnings.ca.gov](http://www.P65Warnings.ca.gov).

**Perchlorate Warning**

California Best Management Practices Regulations for Perchlorate Materials: This Perchlorate warning applies only to products containing CR (Manganese Dioxide) Lithium coin cells. "Perchlorate Material-special handling may apply. See "[www.dtsc.ca.gov/hazardouswaste/perchlorate](http://www.dtsc.ca.gov/hazardouswaste/perchlorate)"

この装置は、クラスA機器です。この装置を住宅環境で使用すると電波妨害を引き起こすことがあります。この場合には使用者が適切な対策を講ずるよう要求されることがあります。

VCCI - A

## BSMI/RoHS

## 限用物質含有情況標示聲明書

Declaration of the Presence Condition of the Restricted Substances Marking

設備名稱: 伺服器/ Server 型號 (型式) : HS219-R20X13 Equipment name Type designation (Type)						
(系列型號: HS219-R12X13/ HS219-R16X13/ HS219-12/ HS219-16/ HS219-20/ HS829-R20X13 HS829-R12X13/ HS829-R16X13/ HS829-12/ HS829- 16/ HS829- 20/SYS-221H-TN24R /SYS-221H-TNR/SYS-621H-TN12R)						
單元 Unit	限用物質及其化學符號 Restricted substances and its chemical symbols					
	鉛Lead (Pb)	汞Mercury (Hg)	鎘Cadmium (Cd)	六價鉻 Hexavalent chromium (Cr <sup>+6</sup> )	多溴聯苯 Polybrominated biphenyls (PBB)	多溴二苯醚 Polybrominated diphenyl ethers (PBDE)
機殼 (Chassis)	○	○	○	○	○	○
機殼風扇 (Chassis Fan)	—	○	○	○	○	○
線材 (Cable)	○	○	○	○	○	○
主機板 (Motherboard)	—	○	○	○	○	○
電源供應器 (Power Supply)	—	○	○	○	○	○
電源背板 (PDB)	—	○	○	○	○	○
硬碟 (HDD)	—	○	○	○	○	○
附加卡 (Add-on Card)	—	○	○	○	○	○
備考1. “超出0.1 wt %” 及 “超出0.01 wt %” 係指限用物質之百分比含量超出百分比含量基準值。 Note 1 : “Exceeding 0.1 wt %” and “exceeding 0.01 wt %” indicate that the percentage content of the restricted substance exceeds the reference percentage value of presence condition.						
備考2. “○” 係指該項限用物質之百分比含量未超出百分比含量基準值。 Note 2 : “○” indicates that the percentage content of the restricted substance does not exceed the percentage of reference value of presence.						
備考3. “—” 係指該項限用物質為排除項目。 Note 3 : The “—” indicates that the restricted substance corresponds to the exemption.						

警告: 為避免電磁干擾, 本產品不應安裝或使用於住宅環境。

輸入額定:

100-127V ~, 60-50Hz, 12-9A (x2)

200-240V ~, 60-50Hz, 10-9.8A (x2)

\*使用者不能任意拆除或替換內部配備

\*報驗義務人之姓名或名稱: 美超微電腦股份有限公司

\*報驗義務人之地址: 新北市中和區建一路 150 號 3 樓