



X12DHM-6

USER'S MANUAL

Revision 1.1

The information in this user's manual has been carefully reviewed and is believed to be accurate. The manufacturer assumes no responsibility for any inaccuracies that may be contained in this document, and makes no commitment to update or to keep current the information in this manual, or to notify any person or organization of the updates. **Please Note: For the most up-to-date version of this manual, please see our website at www.supermicro.com.**

Super Micro Computer, Inc. ("Supermicro") reserves the right to make changes to the product described in this manual at any time and without notice. This product, including software and documentation, is the property of Supermicro and/or its licensors, and is supplied only under a license. Any use or reproduction of this product is not allowed, except as expressly permitted by the terms of said license.

IN NO EVENT WILL SUPER MICRO COMPUTER, INC. BE LIABLE FOR DIRECT, INDIRECT, SPECIAL, INCIDENTAL, SPECULATIVE OR CONSEQUENTIAL DAMAGES ARISING FROM THE USE OR INABILITY TO USE THIS PRODUCT OR DOCUMENTATION, EVEN IF ADVISED OF THE POSSIBILITY OF SUCH DAMAGES. IN PARTICULAR, SUPER MICRO COMPUTER, INC. SHALL NOT HAVE LIABILITY FOR ANY HARDWARE, SOFTWARE, OR DATA STORED OR USED WITH THE PRODUCT, INCLUDING THE COSTS OF REPAIRING, REPLACING, INTEGRATING, INSTALLING OR RECOVERING SUCH HARDWARE, SOFTWARE, OR DATA.

Any disputes arising between manufacturer and customer shall be governed by the laws of Santa Clara County in the State of California, USA. The State of California, County of Santa Clara shall be the exclusive venue for the resolution of any such disputes. Supermicro's total liability for all claims will not exceed the price paid for the hardware product.

FCC Statement: This equipment has been tested and found to comply with the limits for a Class A digital device pursuant to Part 15 of the FCC Rules. These limits are designed to provide reasonable protection against harmful interference when the equipment is operated in an industrial environment. This equipment generates, uses, and can radiate radio frequency energy and, if not installed and used in accordance with the manufacturer's instruction manual, may cause harmful interference with radio communications. Operation of this equipment in a residential area is likely to cause harmful interference, in which case you will be required to correct the interference at your own expense.

California Best Management Practices Regulations for Perchlorate Materials: This Perchlorate warning applies only to products containing CR (Manganese Dioxide) Lithium coin cells. "Perchlorate Material-special handling may apply. See www.dtsc.ca.gov/hazardouswaste/perchlorate".



WARNING: This product can expose you to chemicals including lead, known to the State of California to cause cancer and birth defects or other reproductive harm. For more information, go to www.P65Warnings.ca.gov.

The products sold by Supermicro are not intended for and will not be used in life support systems, medical equipment, nuclear facilities or systems, aircraft, aircraft devices, aircraft/emergency communication devices or other critical systems whose failure to perform be reasonably expected to result in significant injury or loss of life or catastrophic property damage. Accordingly, Supermicro disclaims any and all liability, and should buyer use or sell such products for use in such ultra-hazardous applications, it does so entirely at its own risk. Furthermore, buyer agrees to fully indemnify, defend and hold Supermicro harmless for and against any and all claims, demands, actions, litigation, and proceedings of any kind arising out of or related to such ultra-hazardous use or sale.

Manual Revision 1.1

Release Date: April 06, 2023

Unless you request and receive written permission from Super Micro Computer, Inc., you may not copy any part of this document. Information in this document is subject to change without notice. Other products and companies referred to herein are trademarks or registered trademarks of their respective companies or mark holders.

Copyright © 2023 by Super Micro Computer, Inc.

All rights reserved.

Printed in the United States of America

Preface

About This Manual

This manual is written for system integrators, IT technicians and knowledgeable end users. It provides information for the installation and use of the X12DHM-6 motherboard.

About This Motherboard

The Supermicro X12DHM-6 supports the 3rd Gen Intel® Xeon® Scalable Processors (Socket P0-LGA 3647) with up to 40 CPU cores per CPU and the Thermal Design Power (TDP) of up to 270W. Built with the Intel C621A chipset, the X12DHM-6 supports up to 8TB 3DS LRDIMM/LRDIMM/3DS RDIMM/RDIMM DDR4 ECC memory with speeds of 3200/2933/2666 MHz in 32 DIMMs and up to 8TB Intel® Optane™ PMem 200 Series memory with speeds up to 3200 MHz. (See the notes below). In addition, this motherboard features superior IO expandability, including four PCIe 4.0 x16 slots, two PCIe 4.0 AIOM (OCP 3.0 comp) x16 slots, eight PCIe 4.0 x4 NVMe ports, eight SATA 3.0 ports, two M.2 slots, and four USB 3.0 ports. It also offers the most advanced data protection capability that encompasses TPM (Trusted Platform Module) and RoT (Root of Trust) support. The X12DHM-6 is optimized for high-performance, high-end computing platforms and is ideal for enterprise applications, HPC, big data, software-defined storage, private cloud, 5G telecommunication, and edge computing. Please note that this motherboard is intended to be installed and serviced by professional technicians only. For processor/memory updates, please refer to our website at <http://www.supermicro.com/products/>.



Note 1: Intel® Optane™ Persistent Memory (PMem) 200 Series is supported by the 3rd Gen Intel Xeon Scalable (83xx/63xx/53xx/4314 Series) Processors.

Note 2: Memory speed support depends on the processors used in the system.

Conventions Used in the Manual

Special attention should be given to the following symbols for proper installation and to prevent damage done to the components or injury to yourself:



Warning! Indicates important information given to prevent equipment/property damage or personal injury.



Warning! Indicates high voltage may be encountered while performing a procedure.



Important: Important information given to ensure proper system installation or to relay safety precautions.



Note: Additional Information given to differentiate various models or to provide information for proper system setup.

Contacting Supermicro

Headquarters

Address: Super Micro Computer, Inc.
980 Rock Ave.
San Jose, CA 95131 U.S.A.

Tel: +1 (408) 503-8000

Fax: +1 (408) 503-8008

Email: marketing@supermicro.com (General Information)
Sales-USA@supermicro.com (Sales Inquiries)
Government_Sales-USA@supermicro.com (Gov. Sales Inquiries)
support@supermicro.com (Technical Support)
RMA@supermicro.com (RMA Support)
Webmaster@supermicro.com (Webmaster)

Website: www.supermicro.com

Europe

Address: Super Micro Computer B.V.
Het Sterrenbeeld 28, 5215 ML
's-Hertogenbosch, The Netherlands

Tel: +31 (0) 73-6400390

Fax: +31 (0) 73-6416525

Email: sales_Europe@supermicro.com (Sales Inquiries)
support_Europe@supermicro.com (Technical Support)
RMA_Europe@supermicro.com (RMA Support)

Website: www.supermicro.nl

Asia-Pacific

Address: Super Micro Computer, Inc.
3F, No. 150, Jian 1st Rd.
Zhonghe Dist., New Taipei City 235
Taiwan (R.O.C)

Tel: +886-(2) 8226-3990

Fax: +886-(2) 8226-3992

Email: Sales-Asia@supermicro.com.tw (Sales Inquiries)
Support@supermicro.com.tw (Technical Support)
RMA@supermicro.com.tw (RMA Support)

Website: www.supermicro.com.tw

Table of Contents

Chapter 1 Introduction

1.1 Checklist	7
1.2 Processor and Chipset Support	17
1.3 Special Features	18
1.4 System Health Monitoring	18
1.5 ACPI Features	19
1.6 Power Supply	19
1.7 Serial Port.....	19
1.8 Intel® Optane™ Persistent Memory (PMem) 200 Series Overview.....	20

Chapter 2 Installation

2.1 Static-Sensitive Devices	21
2.2 Processor and Heatsink Installation	22
2.3 Motherboard Installation	38
2.4 Memory Support and Installation	43
2.5 I/O Ports	49
2.6 Front Control Panel	50
2.7 Connectors	56
2.8 Jumper Settings	69
2.9 LED Indicators.....	73

Chapter 3 Troubleshooting

3.1 Troubleshooting Procedures	76
3.2 Technical Support Procedures	79
3.3 Frequently Asked Questions	80
3.4 Battery Removal and Installation	81
3.5 Returning Merchandise for Service.....	82

Chapter 4 UEFI BIOS

4.1 Introduction	83
4.2 Main Setup	84
4.3 Advanced Setup Configurations.....	86
4.4 Event Logs	138
4.5 BMC.....	140
4.6 Security.....	143

4.7 Boot148

4.8 Save & Exit.....150

Appendix A BIOS POST Codes

A.1 BIOS POST Codes.....152

Appendix B Software

B.1 Microsoft Windows OS Installation.....153

B.2 Driver Installation.....155

B.3 SuperDoctor® 5.....156

B.4 BMC.....157

B.5 Logging into the BMC (Baseboard Management Controller).....157

Appendix C Standardized Warning Statements

Chapter 1

Introduction

Congratulations on purchasing your computer motherboard from an industry leader. Supermicro motherboards are designed to provide you with the highest standards in quality and performance.

1.1 Checklist

This motherboard was designed to be used in an SMCI-proprietary chassis only as a part of an integrated, complete system solution. It is not intended to be sold as an independent, stand-alone product; therefore, no shipping package will be included in the shipment.

Important Links

For your system to work properly, please follow the links below to download all necessary drivers/utilities and the user's manual for your motherboard.

- Supermicro product manuals: <http://www.supermicro.com/support/manuals/>
- Product drivers and utilities: <https://www.supermicro.com/wdl/driver>
- Product safety info: http://www.supermicro.com/about/policies/safety_information.cfm
- If you have any questions, please contact our support team at: support@supermicro.com
- A secure data deletion tool designed to fully erase all data from storage devices can be found at our website: https://www.supermicro.com/about/policies/disclaimer.cfm?url=/wdl/utility/Lot9_Secure_Data_Deletion_Utility/

This manual may be periodically updated without notice. Please check the Supermicro website for possible updates to the manual revision level.

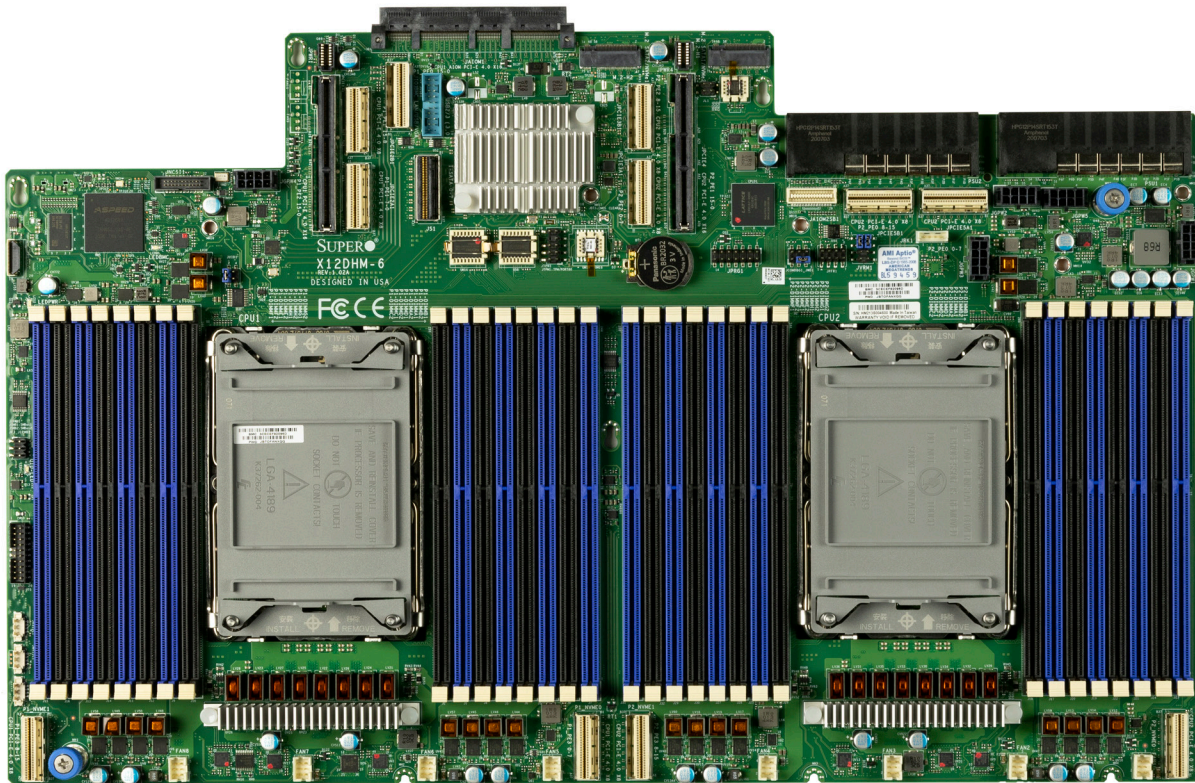

X12DHM-6 Motherboard Image

 **Note:** All graphics shown in this manual were based upon the latest PCB revision available at the time of publication of the manual. The motherboard you received may or may not look exactly the same as the graphics shown in this manual.

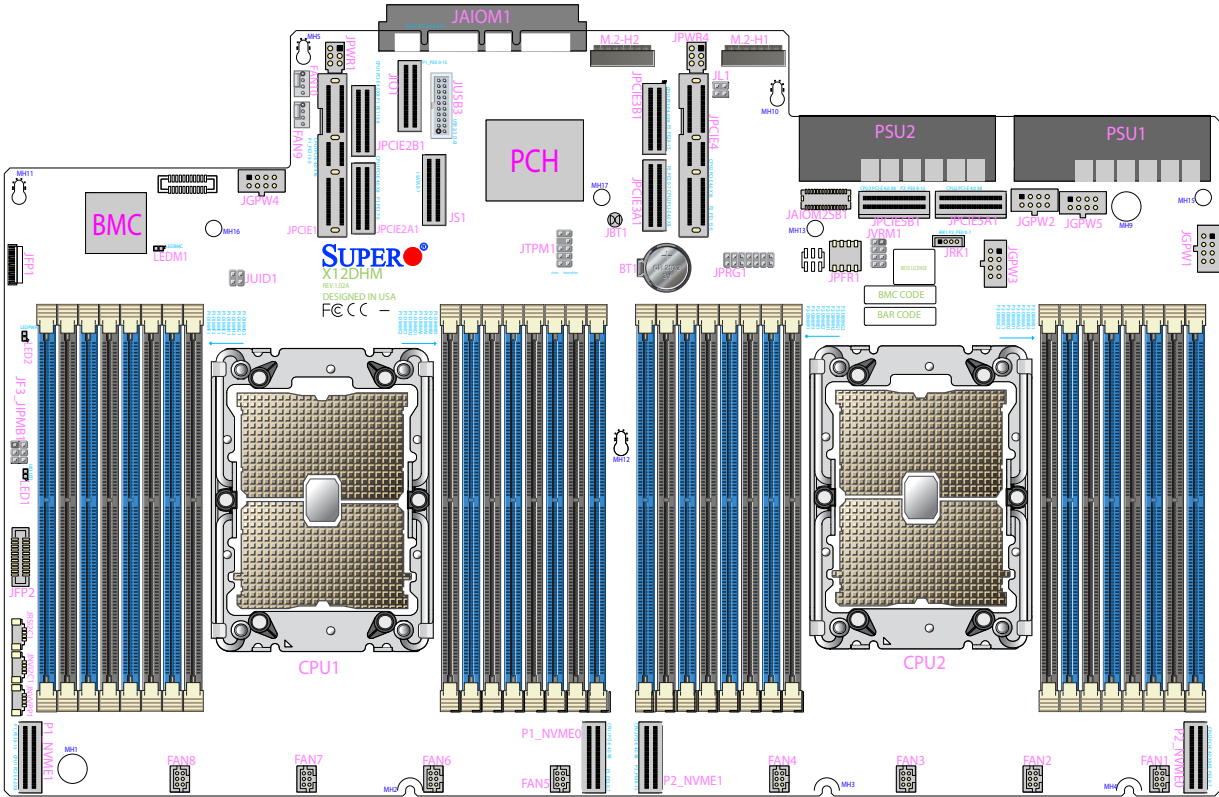

X12DHM-6 Motherboard Layout

 **Note:** Components not documented are for internal testing only.

Quick Reference

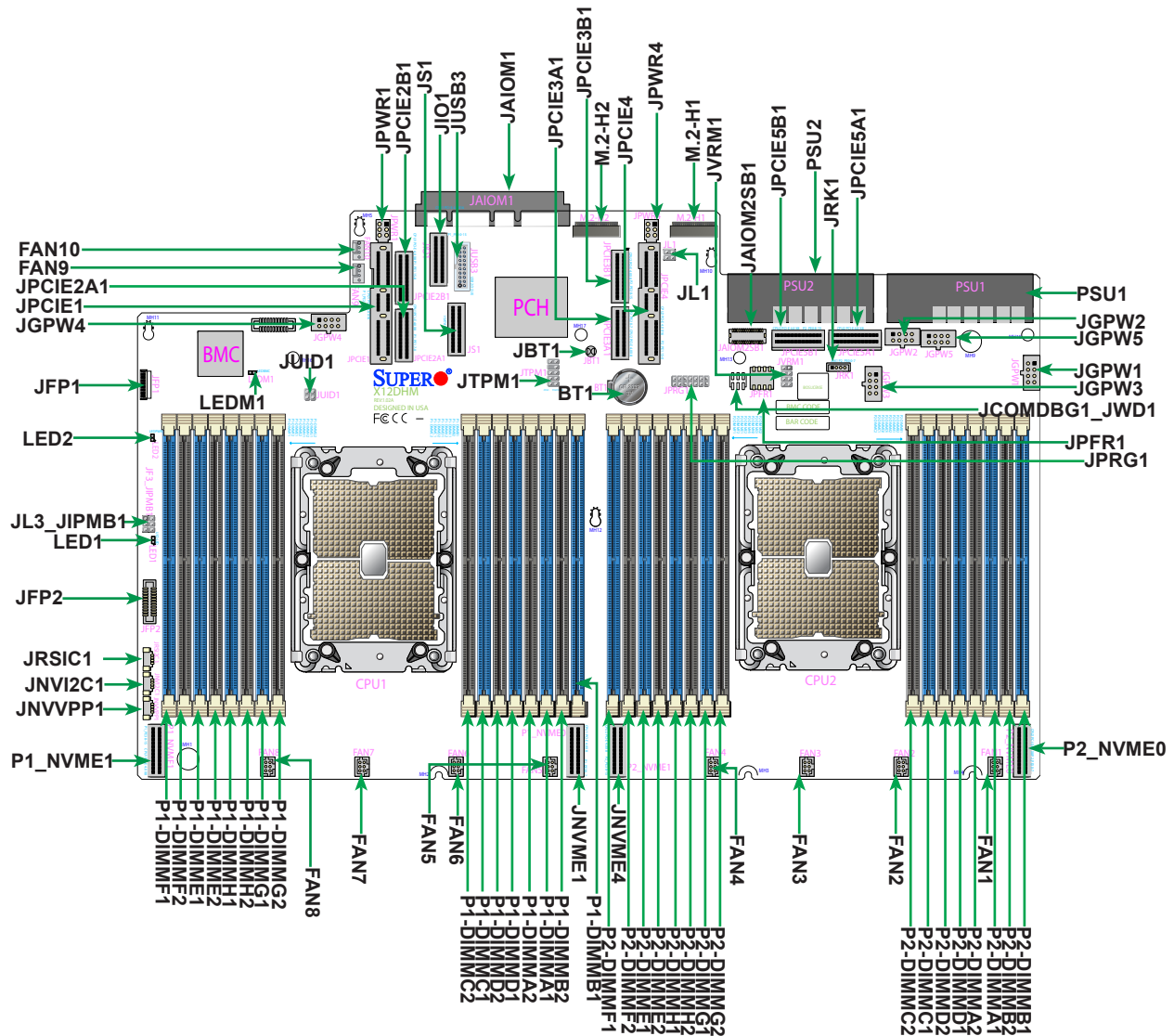

Notes:

- See [Chapter 2](#) for detailed information on jumpers, I/O ports, and JFP1 front panel connections.
- "■" indicates the location of Pin 1.
- Jumpers/LED indicators not indicated are used for testing only.
- Use only the correct type of onboard CMOS battery as specified by the manufacturer. Do not install the onboard battery upside down to avoid possible explosion.

Quick Reference Table

Jumper	Description	Default Setting
JBT1	CMOS Clear	Open (Normal)
JPFR1	Jumper for enable CPLD JTAG	Open (Disabled)
JUID1	Front panel reset/UID switch selection	Pin 1-2 (UID button); Pin 3-4 (reset button)
JVRM1	Jumper for switch VRM SMBus controllers	Pin 1-3/2-4 (BMC)

Connector	Description
BT1	Onboard CMOS battery
FAN1 ~ FAN8	6-pin System Cooling Fan headers
FAN9 ~ FAN10	4-pin CPU Cooling Fan headers
JAIOM1	The Supermicro® Advanced I/O Module (AIOM) slot
JF3_JIPMB1	6-pin BMC External I ² C header (for an BMC card)
JFP1	Front Control Panel header
JFP2	Front VGA header
JGPW1~5	8-pin power output connectors used for GPUs and backplane devices
JIO1	Low profile slimSAS 8x I/O connector
JL1	Chassis Intrusion header
JNVI2C1	NVMe SMBus (I ² C) header used for PCIe hot-plug SMBus clock & data connection
JNVVPP1	CPU VPP bus header for backplane NVMe riser card device
JPCIE1, JPCIE4	CPU PCIe 4.0 x16 slots
JPCIE2A1, JPCIE2B1, JPCIE3A1, JPCIE3B1, JPCIE5A1, JPCIE5B1	CPU PCIe 4.0 x8 slots
JPRG1	Complex-programable logical device (CPLD) header
JPWR1, JPWR4	Power output connectors for PCIe slots
JRSI2C1	SMBus header for riser card
JS1	I-SATA 0~7 connector
JTPM1	Trusted Platform Module/Port 80 connector
JUSB3	USB 3.0 header (with support for two USB 3.0 ports)
M.2-H1/M.2-H2	M.2 PCIe 3.0 x2 or SATA 3.0 hybrid slots (with support for M-Key 2280 and 22110) supported by the PCH
P1_NVME0/P1_NVME1/P2_NVME0/P2_NVME1	NVMe PCIe 4.0 x4 ports (Note: When installing an NVMe device on a motherboard, please be sure to connect JNVME0 first for your system to work properly.)
PSU1~2	Power supply unit connectors
VROC (JRK1)	Intel VROC RAID key header for NVMe SSD





Note: Table is continued on the next page.

LED	Description	Status
LEDM1	BMC Heartbeat LED	Blinking Green: BMC Normal
LED1	Unit Identifier (UID) LED	Solid Blue: Unit Identified
LED2	System Power LED	LED On: Onboard Power On

 **Note 1:** For details on how to configure Network Interface Card (NIC) settings, please refer to the Network Interface Card Configuration User's Guide posted on our website under the link: <http://www.supermicro.com/support/manuals/>.

Note 2: For detailed instructions on how to configure VROC RAID settings, please refer to the VROC RAID Configuration User's Guide posted on the web page under the link: <http://www.supermicro.com/support/manuals/>.

Motherboard Features

Motherboard Features	
CPU	<ul style="list-style-type: none"> Supports two 3rd Gen Intel Xeon Scalable Processors (Socket P0) with up to 40 CPU cores per CPU and the Thermal Design Power of up to 270W
Memory	<ul style="list-style-type: none"> Supports up to 8TB 3DS LRDIMM/LRDIMM/3DS RDIMM/RDIMM DDR4 (288-pin) ECC memory with speeds of 3200/2933/2666 MHz in 32 memory slots and up to 8TB Intel Optane PMem 200 Series with speeds of up to 3200 MHz <p> Note 1: Intel® Optane™ Persistent Memory (PMem) 200 Series is supported by the 3rd Gen Intel Xeon Scalable (83xx/63xx/53xx/4314 Series) Processors.</p> <p>Note 2: Memory speed and capacity support depends on the processors used in the system.</p>
DIMM Size	<ul style="list-style-type: none"> Up to 256GB at 1.2V <p> Note: For the latest CPU/memory updates, please refer to our website at http://www.supermicro.com/products/motherboard.</p>
Chipset	<ul style="list-style-type: none"> Intel PCH C621A
Expansion Slots	<ul style="list-style-type: none"> Eight PCIe 4.0 x4 NVMe ports Four PCIe 4.0 x16 slots Two M.2 PCIe 3.0 x4 NVMe/SATA hybrid slots (with support for M-Key 2280 and 22110) Two AIOM (Advanced I/O Module) PCIe 4.0 x16 slots
Network	<ul style="list-style-type: none"> 1G Ethernet LAN port supported by PCH
Baseboard Management Controller (BMC)	<ul style="list-style-type: none"> ASPEED AST2600 BMC
Graphics	<ul style="list-style-type: none"> Graphics controller via ASPEED AST2600 BMC
I/O Devices	<ul style="list-style-type: none"> One low profile slimSAS x8 I/O connector (JIO1) that connects to a I/O mezzanine board via a cable to provide VGA/COM/USB*2/RJ45 (BMC_LAN) connections



Note: The table above is continued on the next page.

Motherboard Features

Peripheral Devices

- Two USB 3.0 ports on the I/O riser board via a cable
- One USB 3.0 header on the motherboard supports two USB connections

BIOS

- 256Mb AMI BIOS® SPI Flash BIOS
- ACPI 6.0, Plug and Play (PnP), BIOS rescue hot-key, riser card auto detection support, and SMBIOS 3.0 or later

Power Management

- ACPI power management
- Power button override mechanism
- Power-on mode for AC power recovery
- Wake-on-LAN
- Power supply monitoring

System Health Monitoring

- Onboard voltage monitoring for +12V, +5V, +3.3V, CPU, Memory, VBAT, +5V stdby, +3.3V stdby, +1.8V PCH, +1.05V PCH, +1.0V PCH, CPU temperature, VRM temperature, LAN temperature, PCH temperature, system temperature, and memory temperature
- 7 CPU switch phase voltage regulator
- CPU thermal trip support
- Platform Environment Control Interface (PECI)/TSI

Fan Control

- Fan status monitoring via BMC connections
- Single cooling zone
- Low-noise fan speed control
- Eight Hot-swappable 6-pin fan headers
- Two 4-pin fan headers

System Management

- Trusted Platform Module (TPM) support
- SuperDoctor® 5
- Server Platform Service

LED Indicators

- Power LED
- Two LAN activity LEDs
- BMC Heartbeat LED
- Two hard drive activity LEDs

Dimensions

- 10.7"(W) x 17"(L) (271.78 mm x 431.80 mm)

 **Note 1:** The CPU maximum thermal design power (TDP) is subject to chassis and heatsink cooling restrictions. For proper thermal management, please check the chassis and heatsink specifications.

Note 2: For BMC configuration instructions, please refer to the Embedded BMC Configuration User's Guide available at <http://www.supermicro.com/support/manuals/>.

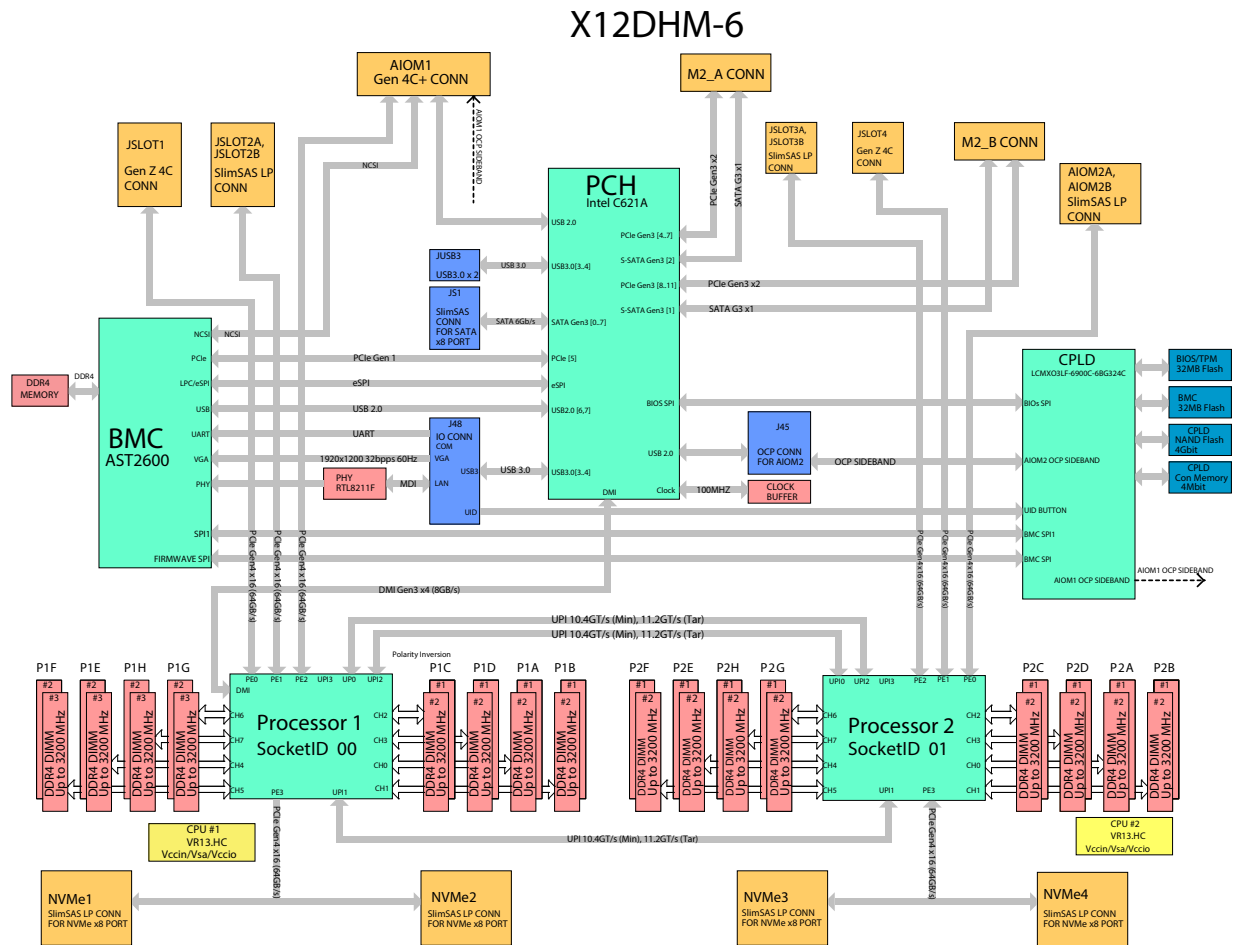

X12DHM-6 Block Diagram

 **Note :** This is a general block diagram and may not exactly represent the features on your motherboard. See the previous pages for the actual specifications of your motherboard.

1.2 Processor and Chipset Support

Built upon the functionality and capability of the 3rd Gen Intel Xeon Scalable Processors (Socket P0) and the Intel C621A chipset, the X12DHM-6 motherboard improves energy efficiency and system performance for a multitude of applications such as enterprise applications, HPC, big data, software-defined storage, private cloud, 5G telecommunication, and edge computing.

Features Supported

- Performance improvements with higher core counts, up to 3UPIs/socket @11.2GT/s
- Vector Neural Network Instructions (VNNI) support to accelerate training
- New hardware-enhanced security features help protect platform and data without compromising performance
- Higher performance storage (PCIe 4.0 NVMe) with double the bandwidth of PCIe 3.0

1.3 Special Features

Recovery from AC Power Loss

The Basic I/O System (BIOS) provides a setting that determines how the system will respond when AC power is lost and then restored to the system. You can choose for the system to remain powered off (in which case you must press the power switch to turn it back on), or for it to automatically return to the power-on state. See the Advanced BIOS Setup section for this setting. The default setting is **Last State**.

1.4 System Health Monitoring

Onboard Voltage Monitors

An onboard voltage monitor will scan the voltages of the onboard chipset, memory, and CPU continuously. Once a voltage becomes unstable, a warning is given, or an error message is sent to the screen.

Fan Status Monitor with Firmware Control

The system health monitor embedded in the BMC chip can check the RPM status of the cooling fans. The CPU and chassis fans are controlled via IPMI.

Environmental Temperature Control

System Health sensors monitor temperatures and voltage settings of onboard processors and the system in real time via the BMC interface. Whenever the temperature of the CPU or the system exceeds a user-defined threshold, system and CPU cooling fans will be turned on to prevent the CPU or the system from overheating.

 **Note:** To avoid possible system overheating, please be sure to provide adequate air-flow to your system.

System Resource Alert

This feature is available when used with SuperDoctor 5® in the Windows OS or in the Linux environment. SuperDoctor is used to notify the user of certain system events. For example, you can configure SuperDoctor to provide you with warnings when the system temperature, CPU temperatures, voltages, and fan speeds go beyond a predefined range.

1.5 ACPI Features

ACPI stands for Advanced Configuration and Power Interface. The ACPI specification defines a flexible and abstract hardware interface that provides a standard way to integrate power management features throughout a computer system, including its hardware, operating system and application software. This enables the system to automatically turn on and off peripherals such as network cards, hard disk drives and printers.

In addition to enabling operating system-directed power management, ACPI also provides a generic system event mechanism for Plug and Play, and an operating system-independent interface for configuration control. ACPI leverages the Plug and Play BIOS data structures, while providing a processor architecture-independent implementation that is compatible with appropriate Windows operating systems. For detailed information regarding OS support, please refer to the Supermicro website.

1.6 Power Supply

As with all computer products, a stable power source is necessary for proper and reliable operation. It is even more important for processors that have high CPU clock rates where noisy power transmission is present.

The X12DHM-6 motherboard accommodates two Supermicro certified power supply units. Five 8-pin and two 6-pin power connectors are also required to ensure adequate power supply to the system.

1.7 Serial Port

The X12DHM-6 motherboard supports one serial communication connections via a I/O riser board. The UART provides legacy speeds with a baud rate of up to 115.2 Kbps as well as an advanced speed with baud rates of 250 K, 500 K, or 1 Mb/s, which support high-speed serial communication devices.

1.8 Intel® Optane™ Persistent Memory (PMem) 200 Series Overview

The 3rd Gen Intel Xeon Scalable Processors support Intel Optane PMem 200 Series memory. Intel Optane PMem offers higher capacities than the traditional DDR4 modules. It also provides increased storage capabilities due to data persistence in a DDR4 form factor for higher performance computing platforms with flexible configuration options.



Note: Intel® Optane™ Persistent Memory (PMem) 200 Series is supported by the 3rd Gen Intel Xeon Scalable (83xx/63xx/53xx/4314 Series) Processors.

Chapter 2

Installation

2.1 Static-Sensitive Devices

Electrostatic Discharge (ESD) can damage electronic components. To avoid damaging your system board, it is important to handle it very carefully. The following measures are generally sufficient to protect your equipment from ESD.

Precautions

- Use a grounded wrist strap designed to prevent static discharge.
- Touch a grounded metal object before removing the board from the antistatic bag.
- Handle the motherboard by its edges only; do not touch its components, peripheral chips, memory modules or gold contacts.
- When handling chips or modules, avoid touching their pins.
- Put the motherboard and peripherals back into their antistatic bags when not in use.
- For grounding purposes, make sure that your computer chassis provides excellent conductivity between the power supply, the case, the mounting fasteners and the motherboard.
- Use only the correct type of onboard CMOS battery. Do not install the onboard battery upside down to avoid possible explosion.

Unpacking

The motherboard is shipped in antistatic packaging to avoid static damage. When unpacking the motherboard, make sure that the person handling it is static protected.

2.2 Processor and Heatsink Installation

The processor (CPU) and processor carrier should be assembled together first to form the processor carrier assembly. This will be attached to the heatsink to form the processor heatsink module (PHM) before being installed into the CPU socket. Before installation, be sure to perform the following steps below:

- Please carefully follow the instructions given on the previous page to avoid ESD-related damages.
- Unplug the AC power cords from all power supplies after shutting down the system.
- Check that the plastic protective cover is on the CPU socket and none of the socket pins are bent. If they are, contact your retailer.
- When handling the processor, avoid touching or placing direct pressure on the LGA lands (gold contacts). Improper installation or socket misalignment can cause serious damage to the processor or CPU socket, which may require manufacturer repairs.
- Thermal grease is pre-applied on a new heatsink. No additional thermal grease is needed.
- Refer to the Supermicro website for updates on processor and memory support.
- All graphics in this manual are for illustrations only. Your components may look different.

The 3rd Gen Intel Xeon Scalable Processor

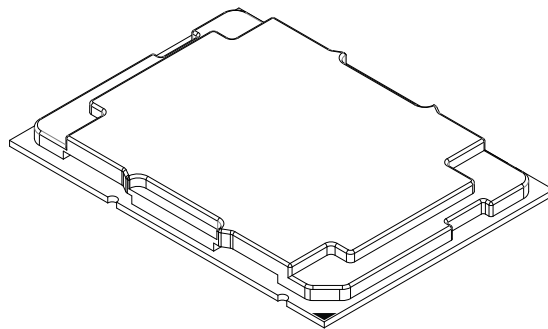

Processor Top View

1. The 3rd Gen Intel Xeon Scalable Processor

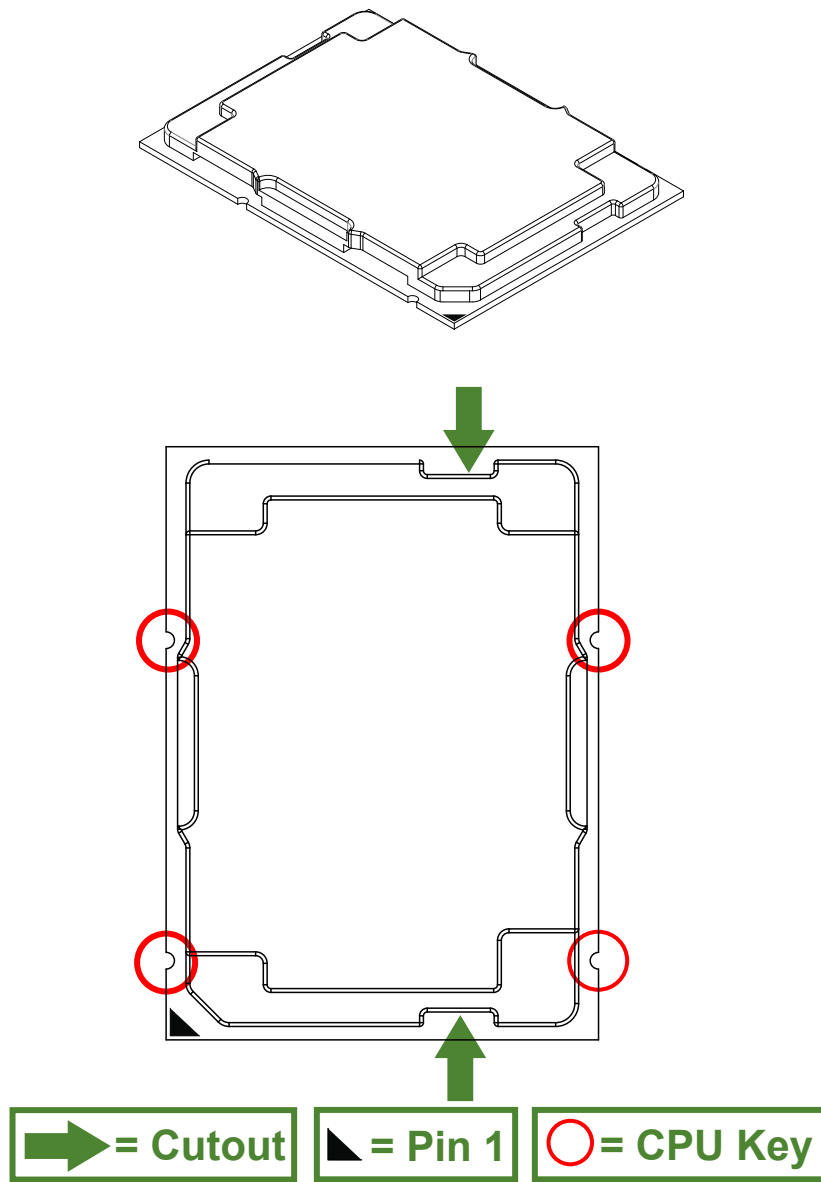

Processor Top View

2. The Processor Carrier

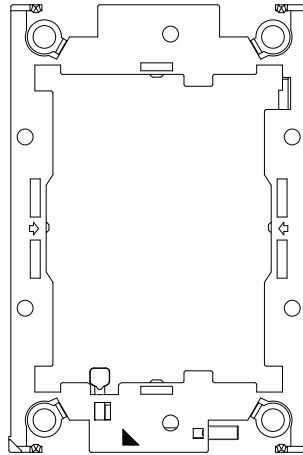
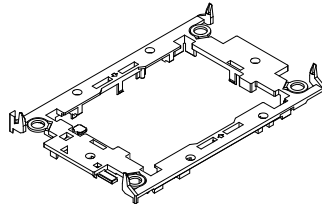

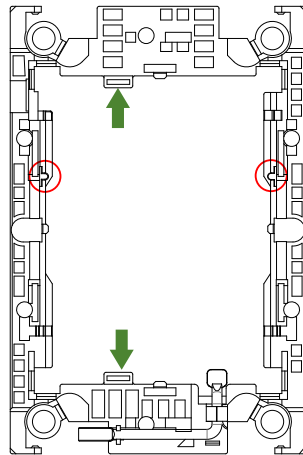

Carrier Top View

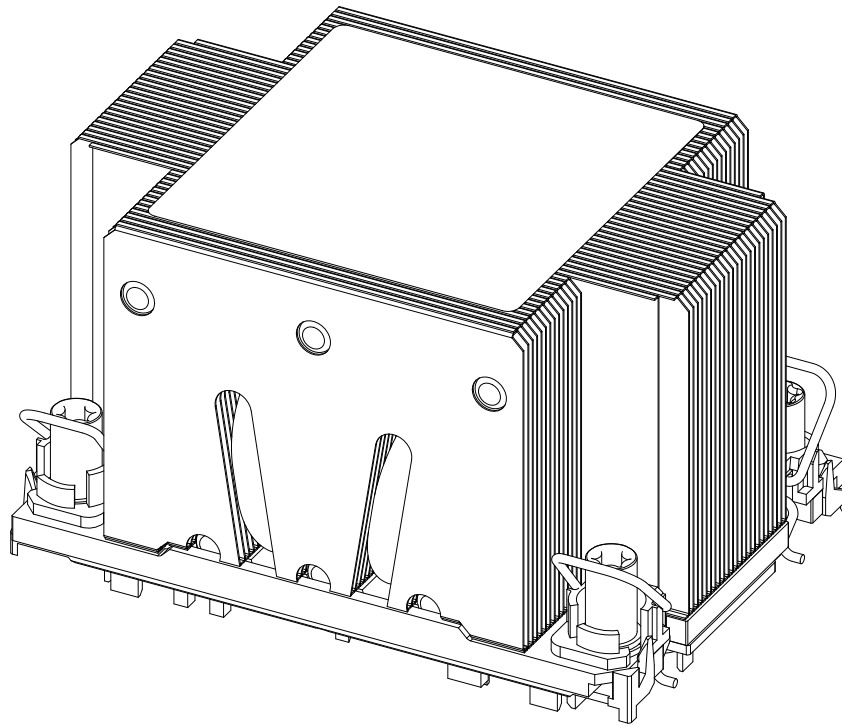

Carrier Bottom View

3. Heatsink



 **Note:** Exercise extreme care when handling the heatsink. Pay attention to the edges of heatsink fins which can be sharp! To avoid damaging the heatsink, please do not apply excessive force on the fins when handling the heatsink.

Overview of the CPU Socket

The CPU socket is protected by a plastic protective cover.

Plastic Protective Cover

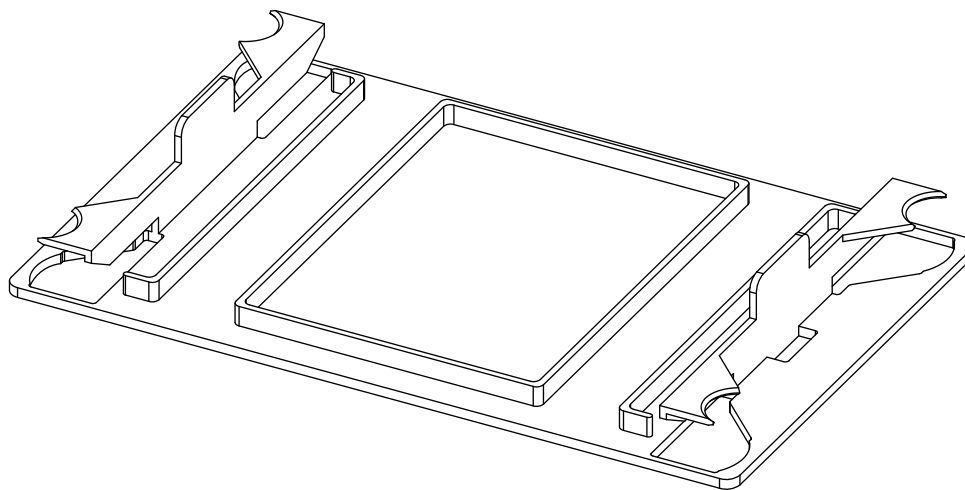

CPU Socket

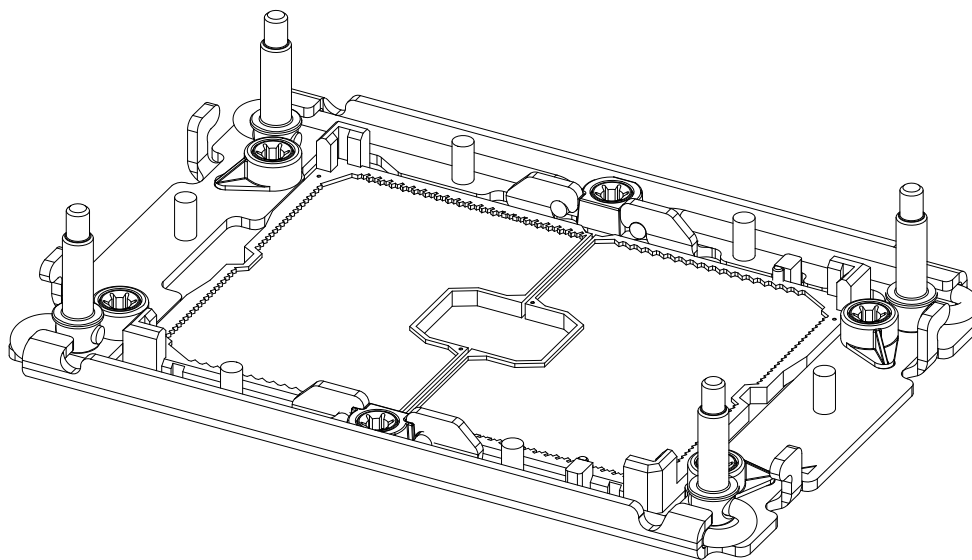

Overview of the Processor Carrier Assembly

The processor carrier assembly contains a 3rd Gen Intel Xeon Scalable processor and a processor carrier. Carefully follow the instructions given in the installation section to place a processor into the carrier to create a processor carrier.

1. The 3rd Gen Intel Xeon Scalable Processor

Intel Processor (Bottom View)

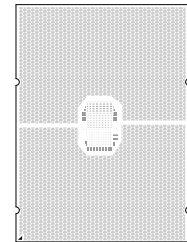

Processor (2D)

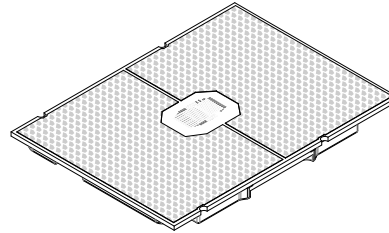

Processor (3D)

2. Processor Carrier

Intel Processor Carrier Top View)

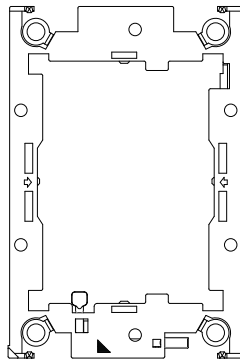

Processor Carrier (2D)

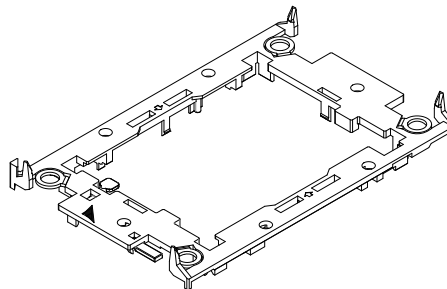

Processor Carrier (3D)



3. Processor Carrier Assembly

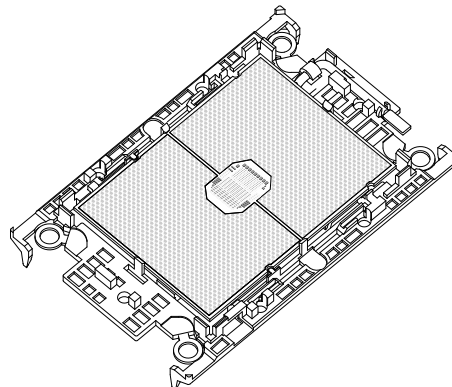

(with Processor Seated inside the Carrier)

Overview of the Processor Heatsink Module

The Processor Heatsink Module (PHM) contains a heatsink, a processor carrier, and a 3rd Gen Intel Xeon Scalable Processor.

1. Heatsink (with Thermal Grease)

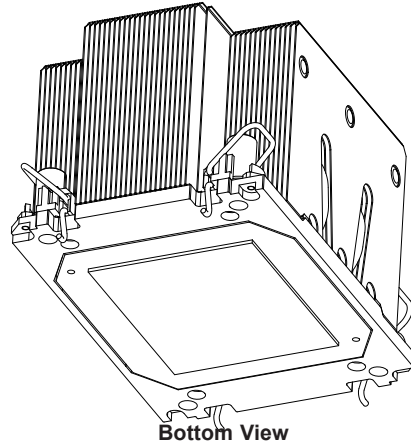

2. Processor Carrier

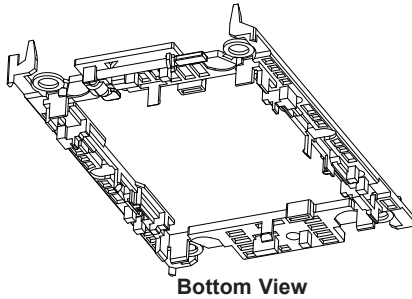

3. The 3rd Gen Intel Xeon Scalable Processor

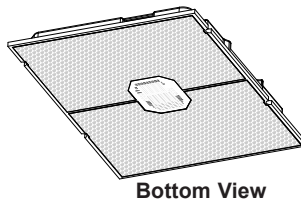

4. Processor Heatsink Module (PHM)

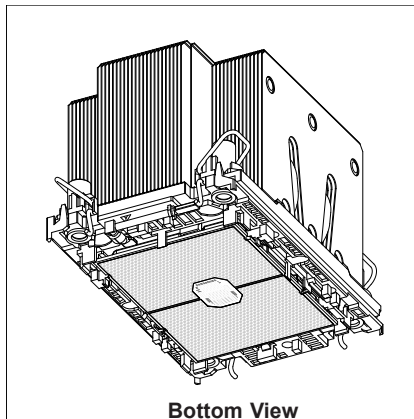

Creating the Processor Carrier Assembly

The processor carrier assembly contains a 3rd Gen Intel Xeon Scalable processor and a processor carrier.

To create the processor carrier assembly, please follow the steps below:

 **Note:** Before installation, be sure to follow the instructions given on Page 1 and Page 2 of this chapter to properly prepare yourself for installation.

1. Hold the processor with the LGA lands (with Gold CPU contacts) facing down. Locate the small, gold triangle at the corner of the processor and the corresponding hollowed triangle on the processor carrier as shown in the graphics below. Please note that the triangle indicates Pin 1 location.

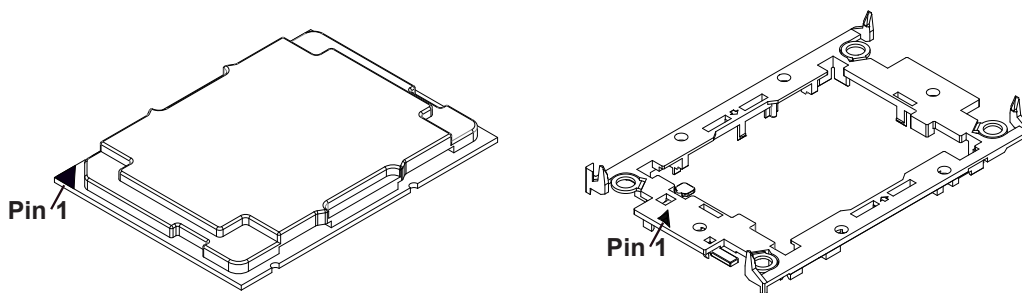

2. First, turn over the processor carrier and locate Pin 1 on the CPU and Pin 1 on the carrier. Then, turn the processor over with the processor reverse side (gold contacts) facing up and locate CPU keys on the processor. Finally, locate the CPU keys and four latches on the carrier as shown below.

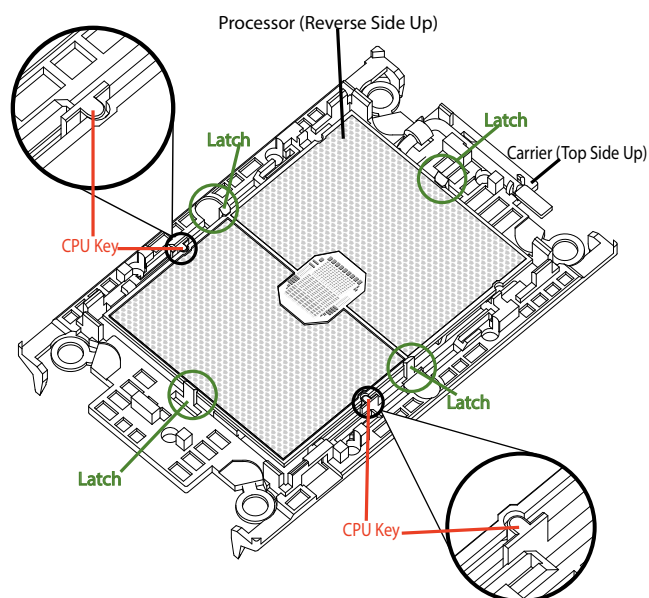

1. Locate the lever on the CPU socket and press the lever down as shown below. Using

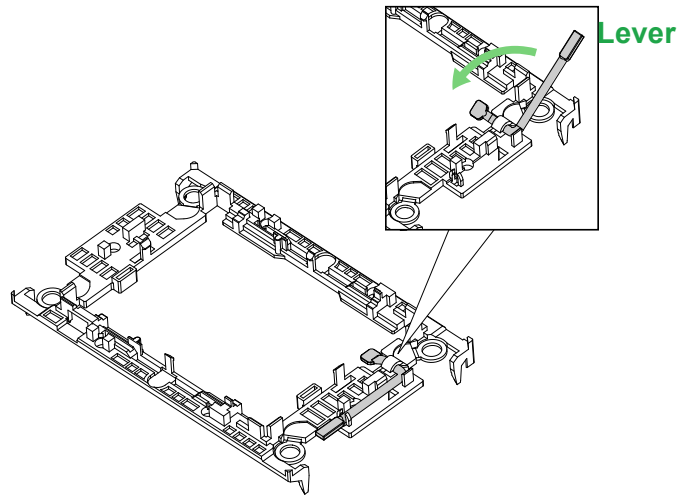

2. Using Pin 1 as a guide, carefully align the CPU keys (A and B) on the processor against the CPU keys on the carrier (a and b) as shown in the drawing below.
3. Once they are properly aligned, carefully place one end of the processor into the latch marked 1 on the carrier, and place the other end of processor into the latch marked 2.

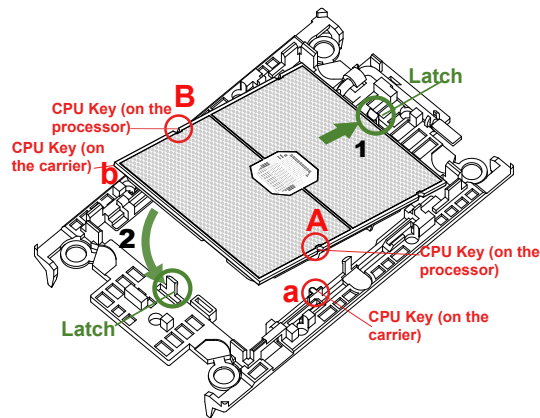

4. After the processor is placed inside the carrier, examine the four sides of the processor, making sure that the processor is properly seated on the carrier.

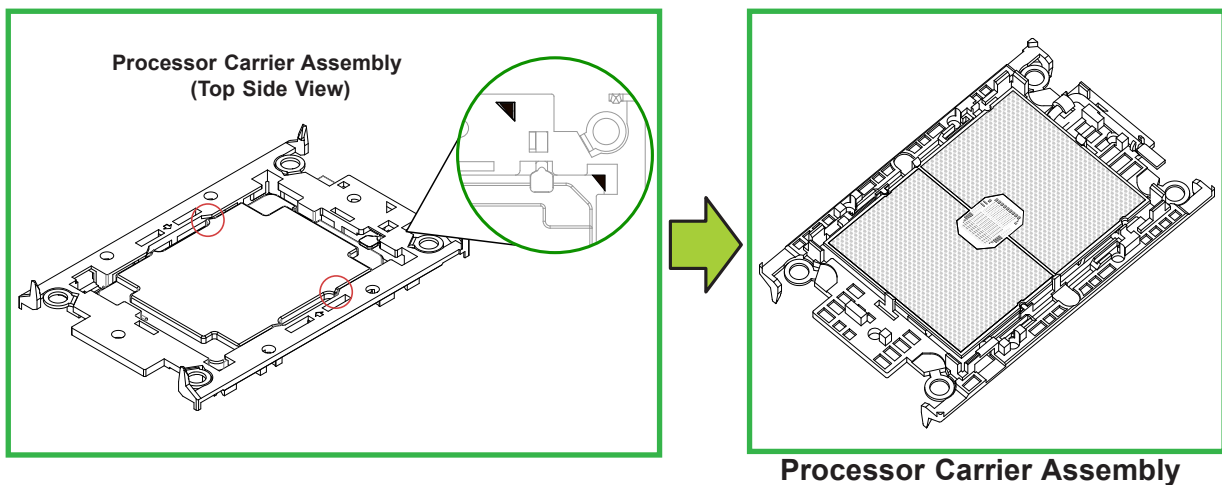

Creating the Processor Heatsink Module (PHM)

After creating the processor carrier assembly, please follow the instructions below to mount the processor carrier into the heatsink to form the processor heatsink module (PHM).

 **Note:** If this is a new heatsink, the thermal grease has been pre-applied on the underside. Otherwise, apply the proper amount of thermal grease.

1. Turn the heatsink over with the thermal grease, which is on the reverse side of the heatsink, facing up. Pay attention to the two triangle cutouts (A, B) located at the diagonal corners of the heatsink as shown in the drawing below.
2. Hold the processor carrier assembly top side (with thermal grease) facing up, and locate the triangle on the CPU and the triangle on the carrier. (Triangle indicates Pin 1.)
3. Using Pin 1 as a guide, turn the processor carrier assembly over with the gold contacts facing up. Locate Pin 1 (A) on the processor and Pin 1 (a) on the processor carrier assembly "a".
4. Align the corner marked "a" on the processor carrier assembly against the triangle cutout "A" on the heatsink, and align the corners marked "b", "c", and "d" on processor assembly against the corners marked "B", "C", and "D" on the heatsinks
5. Once they are properly aligned, place the corner marked "a" on the processor carrier assembly into the corner of the heatsink marked "A". Repeat the same step to place the corners marked "b", "c", and "d" on the processor carrier assembly into the corners of the heatsink marked "B", "C", and "D". Make sure that all plastic clips are properly attached to the heatsink.

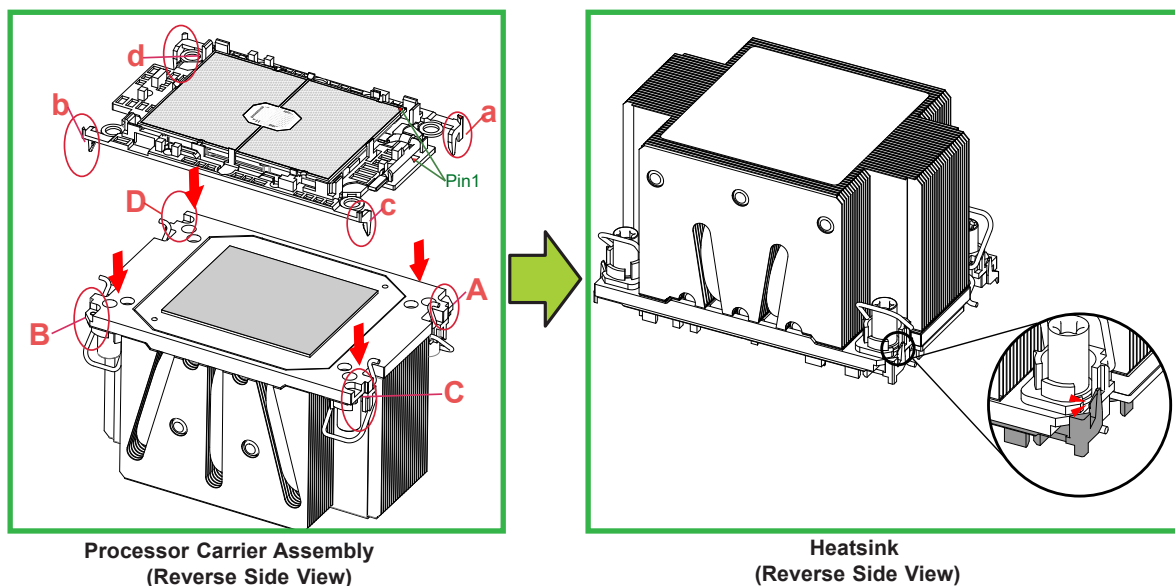

Preparing the CPU Socket for Installation

This motherboard comes with a plastic protective cover installed on the CPU socket. Remove it from the socket to install the Processor Heatsink Module (PHM).

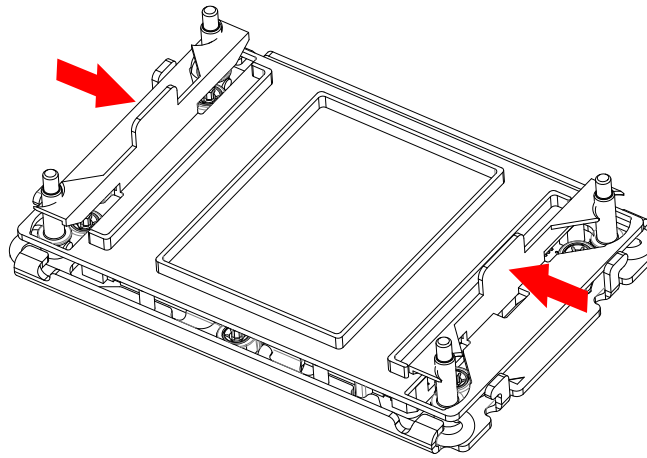

1. Press the tabs inward.

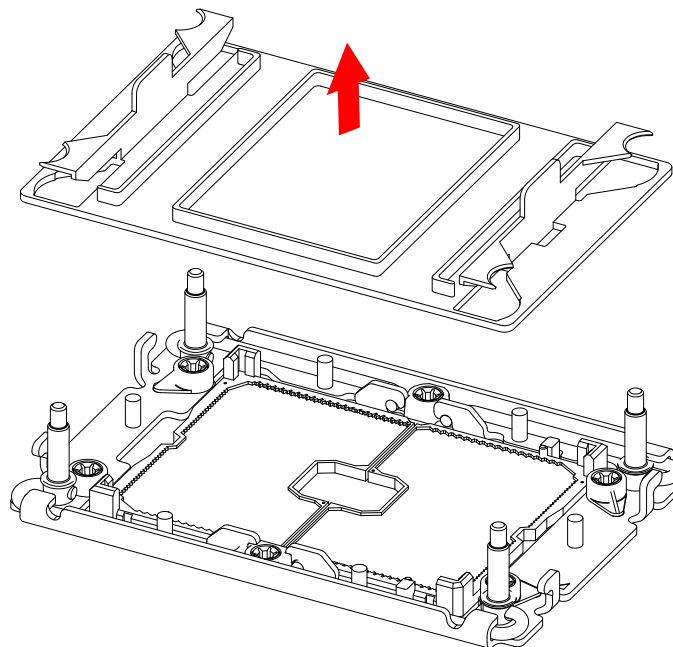

2. Pull up the protective cover from the socket.

Preparing to Install the Processor Heatsink Module (PHM) into the CPU Socket

After assembling the Processor Heatsink Module (PHM), you are ready to install it into the CPU socket. To ensure the proper installation, please follow the procedures below:

1. Locate four threaded fasteners (a, b, c, d) on the CPU socket.

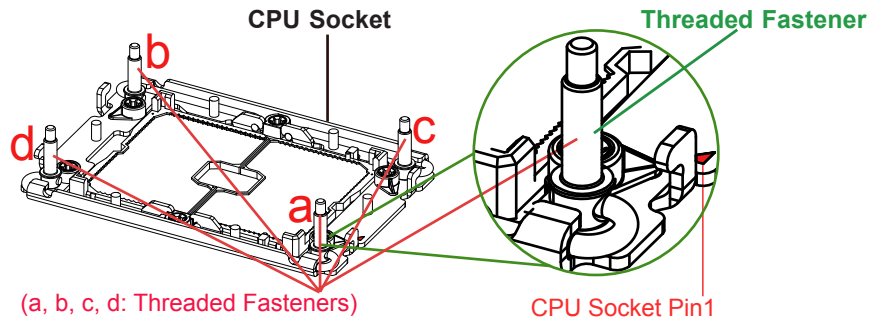

2. Locate four peek nuts (A, B, C, D) and four rotating wires (1, 2, 3, 4) on the heatsink as shown in the graphics below.

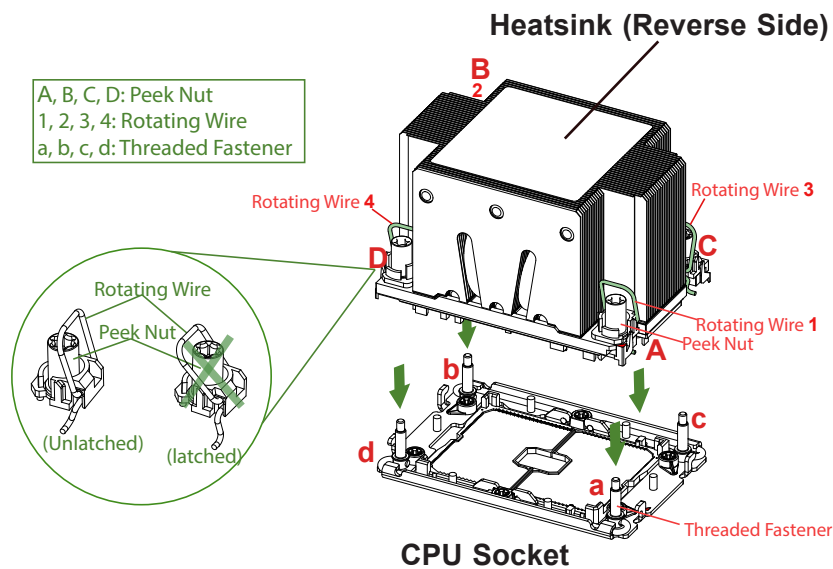

3. Check the rotating wires (1, 2, 3, 4) to make sure that they are at unlatched positions as shown in the drawing below before installing the PHM into the CPU socket.

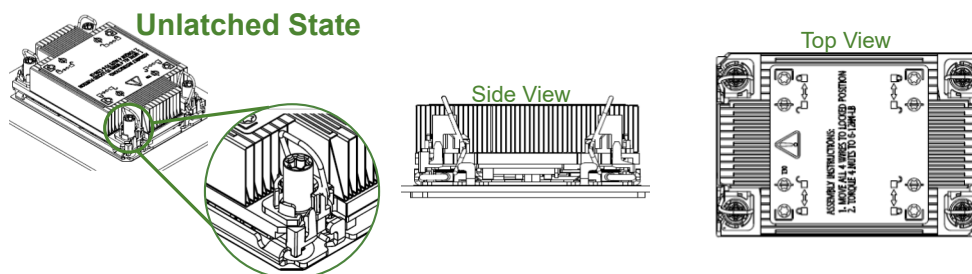

Installing the Processor Heatsink Module (PHM)

1. Align peek nut "A", which is next to the triangle (Pin 1) on the heatsink, against threaded fastener "a" on the CPU socket. Then align peek nuts "B", "C", and "D" on the heatsink against threaded fasteners "b", "c", and "d" on the CPU socket. Make sure that all peek nuts on the heatsink are properly aligned with the correspondent threaded fasteners on the CPU socket.
2. Once they are aligned, gently place the heatsink on top the CPU socket, making sure that each peek nut is properly attached to its corresponding threaded fastener.

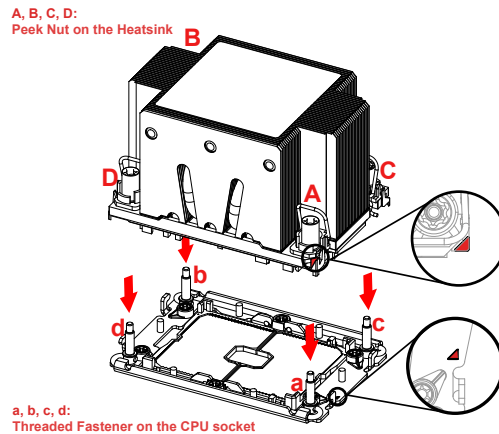

3. Press all four rotating wires outwards and make sure that the heatsink is securely latched onto the CPU socket.

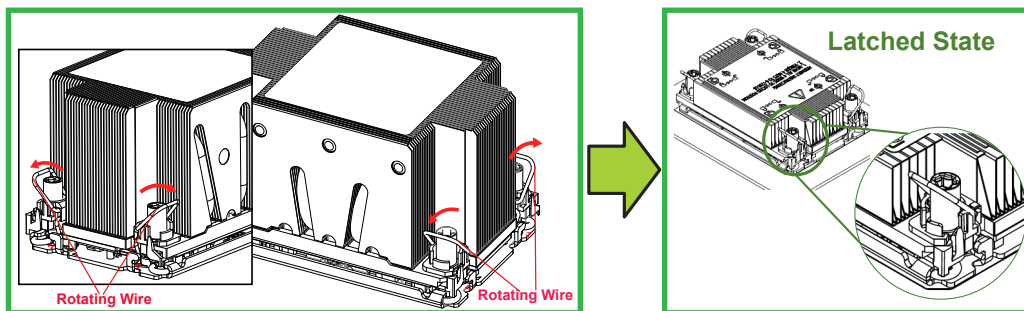

4. With a T30-bit screwdriver, tighten all peek nuts in the sequence of "A", "B", "C", and "D" with even pressure. To avoid damaging the processor or socket, do not use a force greater than 12 lbf-in when tightening the screws.
5. Examine all corners heatsink to ensure that the PHM is firmly attached to the CPU socket.

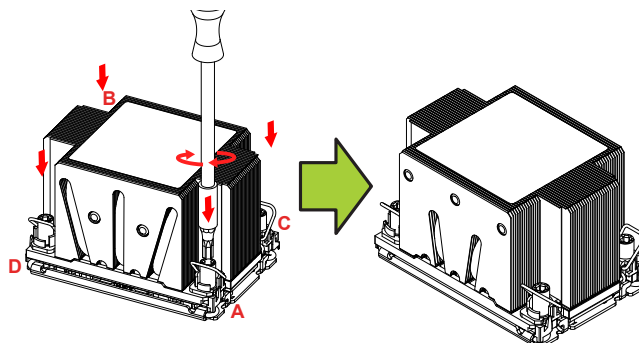

Removing the Processor Heatsink Module from the CPU Socket

Before removing the processor heatsink module (PHM) from the motherboard, unplug the AC power cord from all power supplies after shutting down the system. Then follow the steps below:

1. Use a T30-bit screwdriver to loosen the four peek nuts on the heatsink in the sequence of #A, #B, #C, and #D.

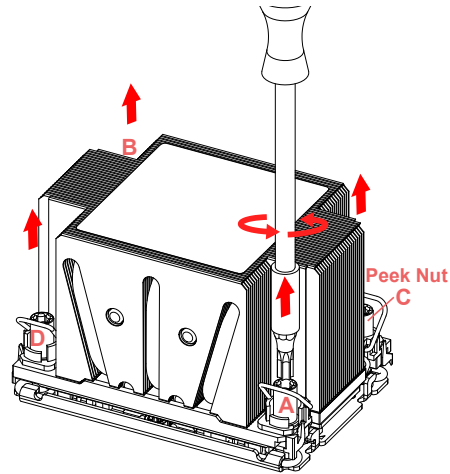

2. Once the peek nuts are loosened from the CPU socket, press the rotating wires inwards to unlatch the PHM from the socket as shown in the drawings below.

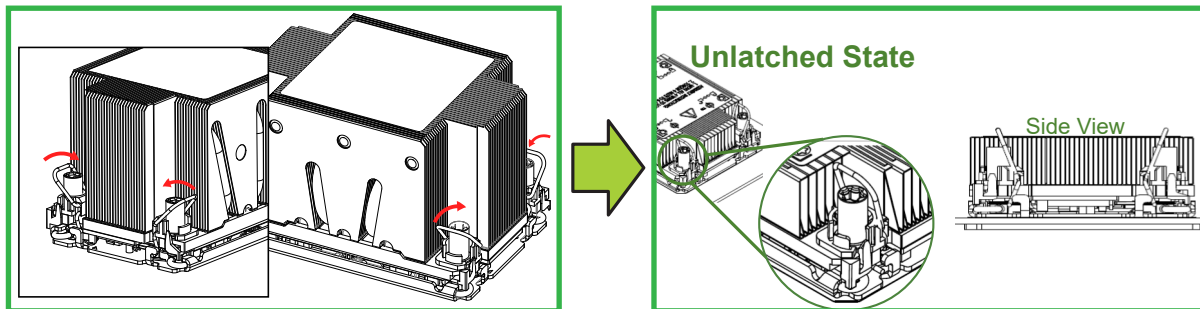

3. Gently lift the PHM upwards to remove it from the CPU socket.

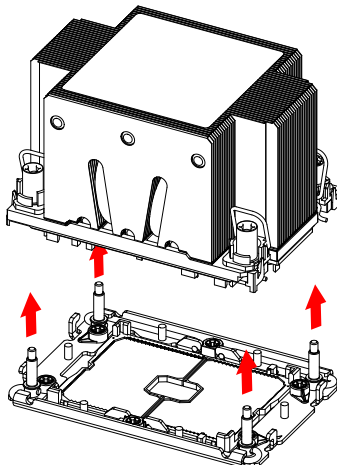

Removing the Processor Carrier Assembly from the Processor Heatsink Module (PHM)

To remove the processor carrier assembly from the PHM, please follow the steps below:

1. Detach four plastic clips (marked a, b, c, d) on the processor carrier assembly from the four corners of heatsink (marked A, B, C, D) in the drawings below.

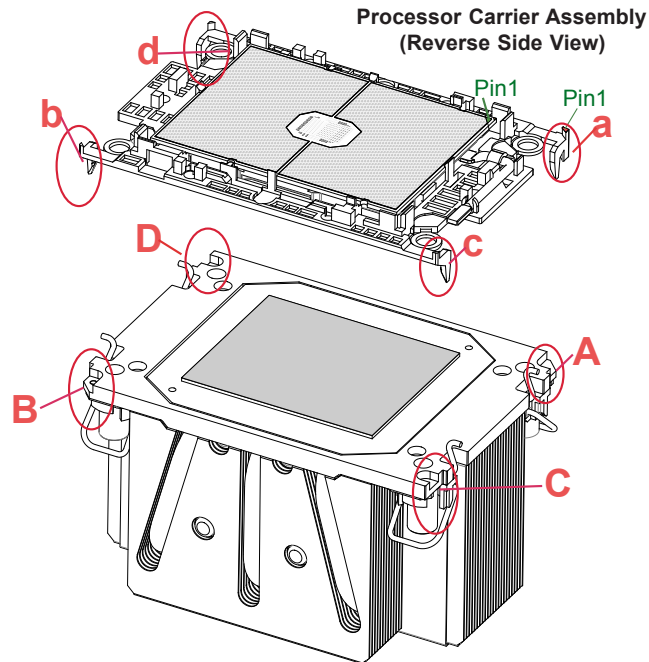

2. When all plastic clips are detached from the heatsink, remove the processor carrier assembly from the heatsink

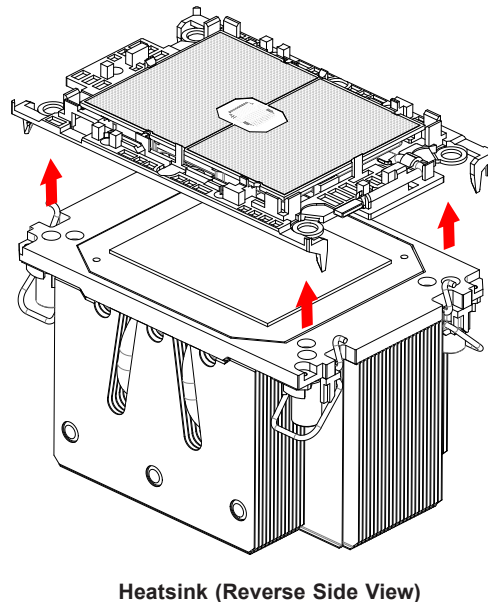

Removing the Processor from the Processor Carrier Assembly

Once you have removed the processor carrier assembly from the PHM, you are ready to remove the processor from the processor carrier by following the steps below.

1. Unlock the lever from its locking position and push the lever upwards to disengage the processor from the processor carrier as shown in the right drawing below.

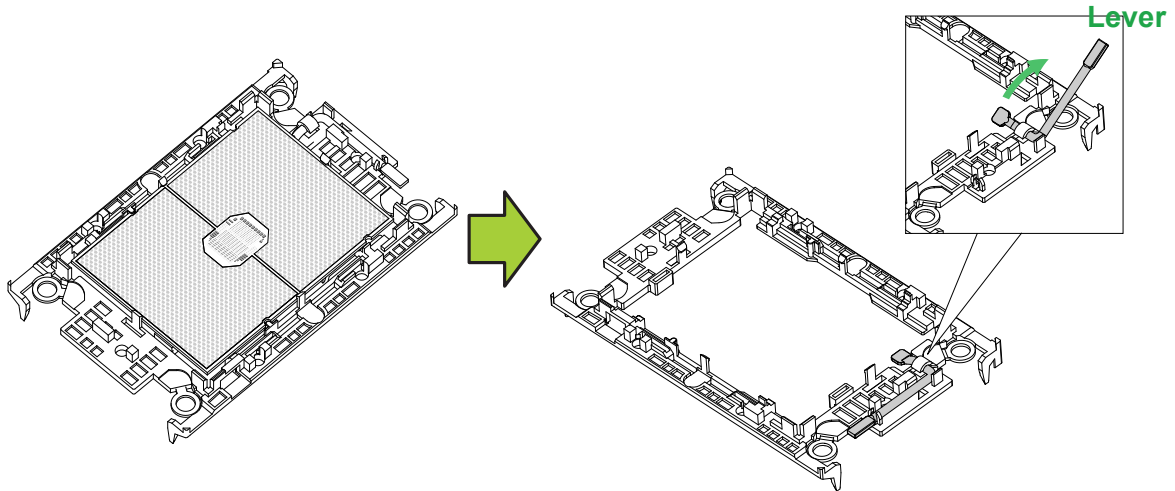

2. Once the processor is loosened from the carrier, carefully remove the processor from the processor carrier.

 **Note:** To avoid damaging the processor and its pins, please handle the processor with care.

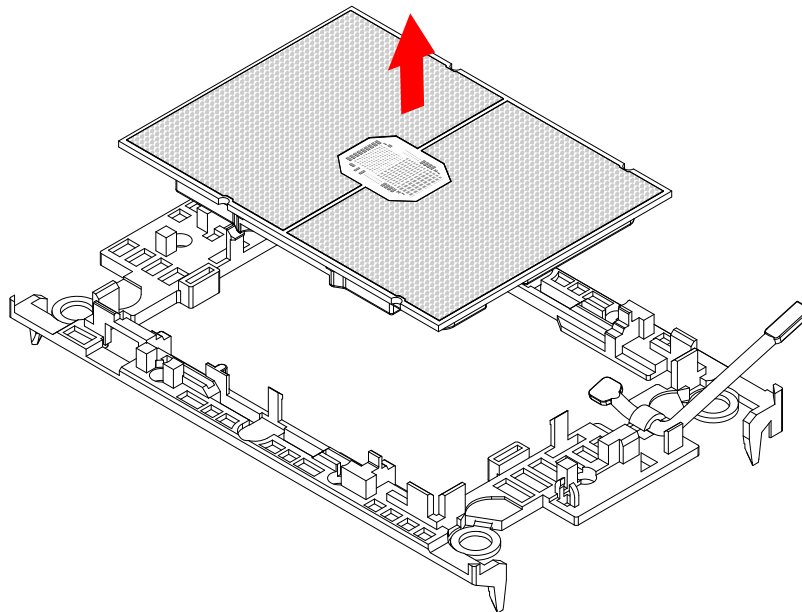

2.3 Motherboard Installation

Two standard mounting holes (MH1 and MH9) are used to install the motherboard into the system chassis. These mounting holes are marked with the green arrows on the layout drawing below. Please carefully align the locations of the mounting holes on the motherboard with the mounting holes on the chassis.

Mounting Holes

 **Note 1:** To avoid damaging the motherboard and its components, please do not use a force greater than 8 lbf-in on each mounting screw during motherboard installation.

Note 2: Some components are very close to the mounting holes. Please take precautionary measures to avoid damaging these components when installing the motherboard to the chassis.

Types of the Mounting Holes

There are three types of mounting holes that serve three different functions on the motherboard. Refer the section below for the descriptions and the locations of the mounting holes.

1. Mounting holes for built-in thumbscrews (MH1, MH9)

- These mounting holes are use for built-in thumbscrews that will help securely attach the motherboard to the chassis.

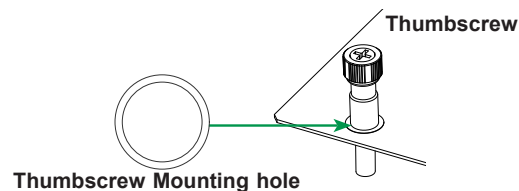

2. Mounting holes for T-pins (MH2, MH3, MH4, MH5, MH10, MH11, MH12)

- These mounting holes are used for T-pins, which will help lock the motherboard to the proper position in the chassis.

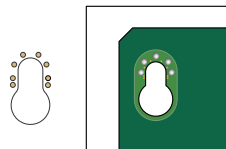

3. Mounting holes for standoffs (MH15, MH16, MH17, MH18, MH19)

- These mounting holes are for standoffs used for heatsink support.



Locations of the Mounting Holes for ThumbScrews and T-Pins

- Thumbscrew Mounting Holes: MH1, MH9
- T-Pins Mounting Holes: MH2, MH3, MH4, MH5, MH10, MH11, MH12

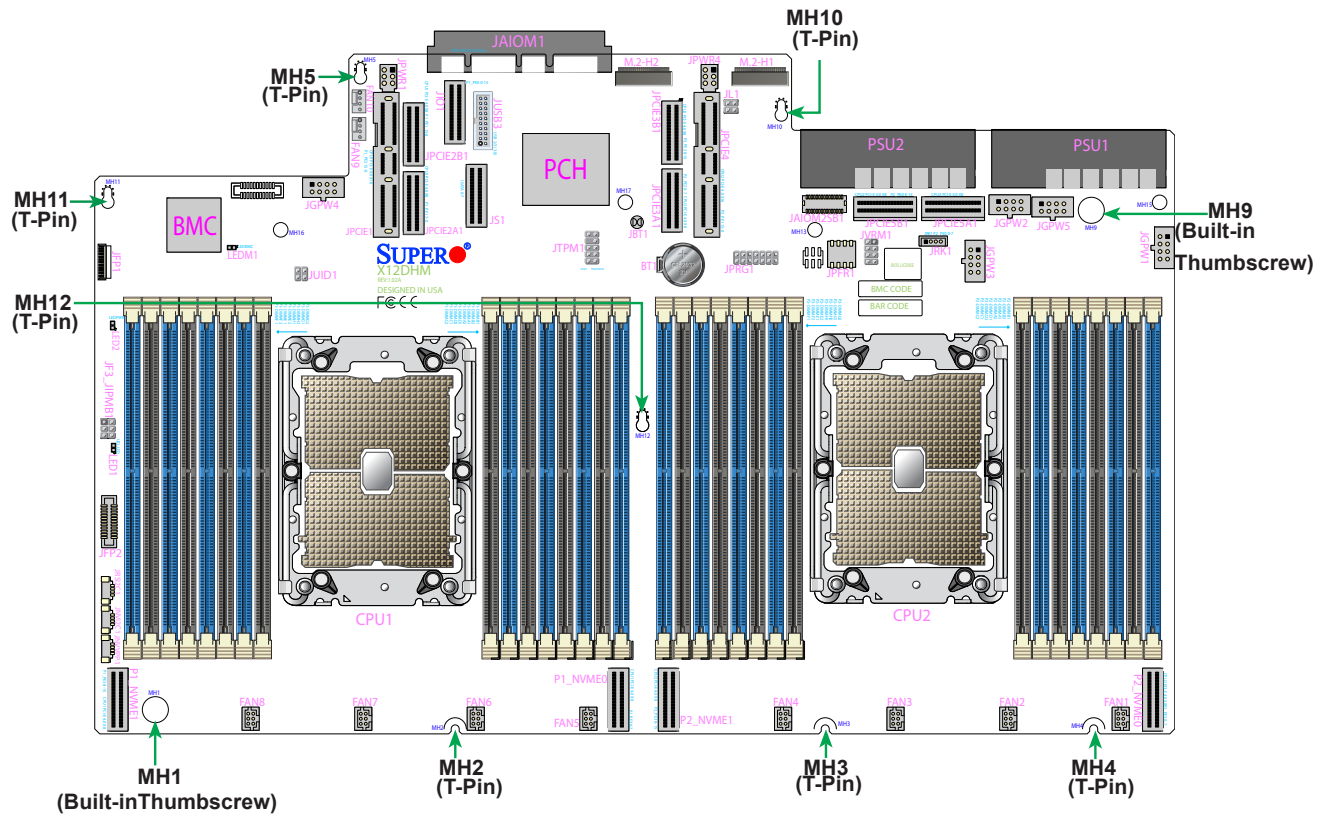

Installing the Motherboard

1. Locate the T-pin mounting holes on the motherboard and their corresponding T-pins in the chassis. (See the previous page for the locations.) Align the T-pin mounting holes on the motherboard against the corresponding T-pins in the chassis.

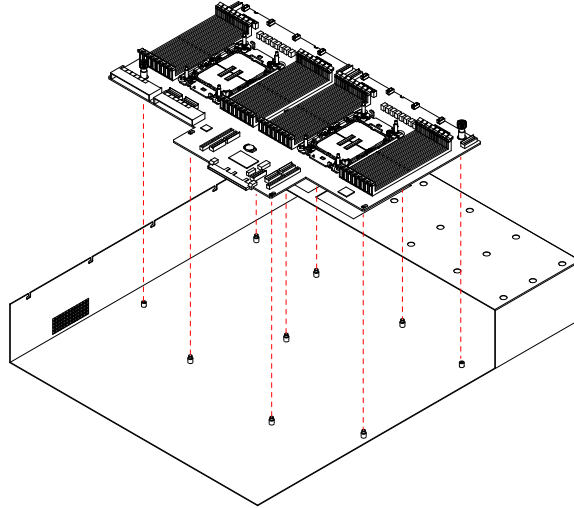

2. After the T-pin mounting holes on the motherboard are properly aligned with their corresponding T-pins in the chassis, hold the motherboard by the two thumbscrews located at MH1 and MH9, and carefully lower the motherboard into the chassis, making sure that all T-pin mounting holes are properly inserted into their corresponding T-pins in the chassis. (Refer to the layout for the locations of the mounting holes.)

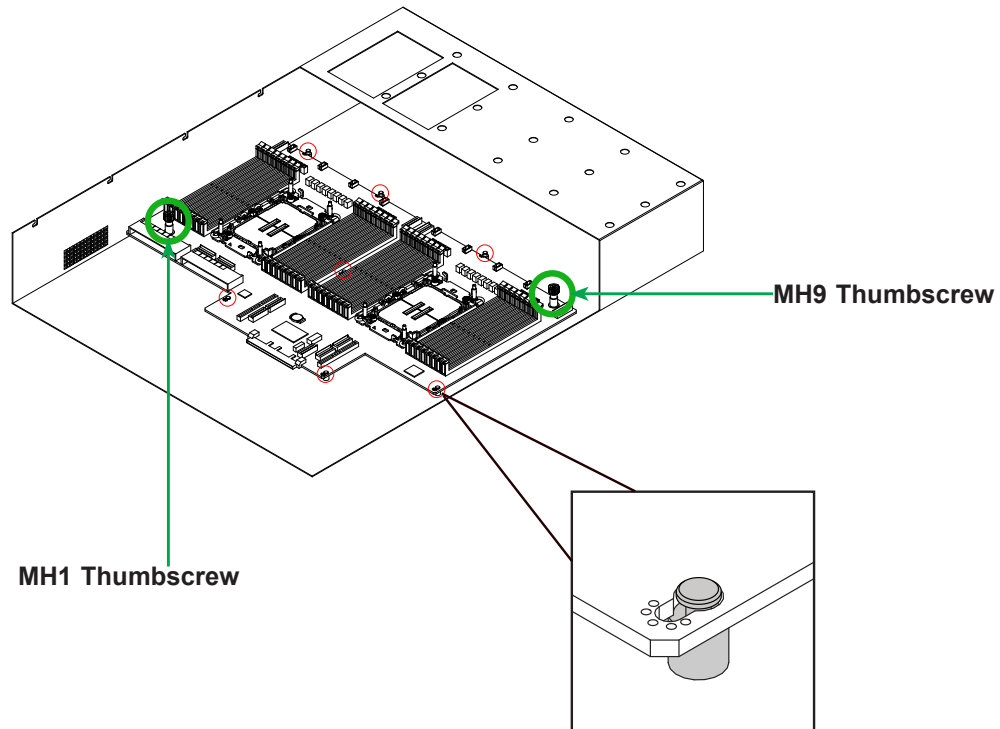

3. After all T-pin mounting holes are properly inserted into their corresponding T-pins in the chassis and the motherboard is properly seated in the chassis, slide the motherboard toward the rear side of the chassis making sure that all T-pin mounting holes are securely locked into the corresponding T-pins in the chassis.

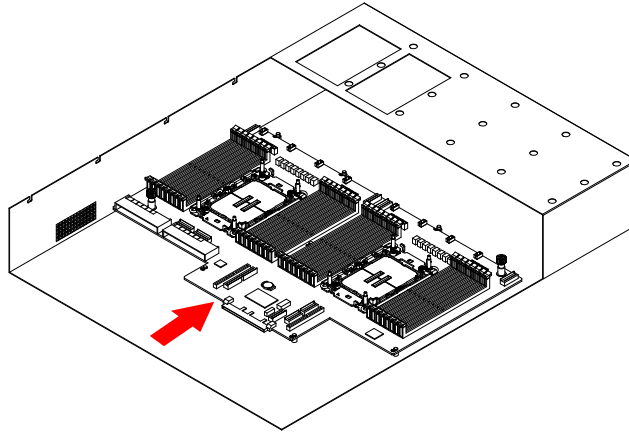

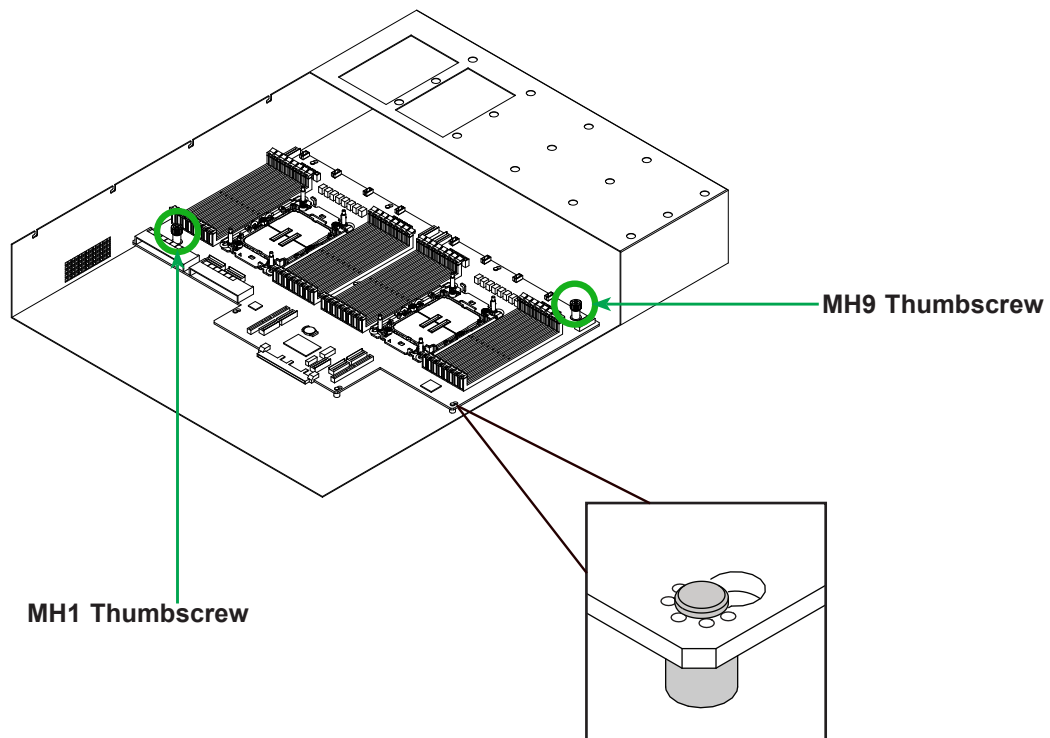

4. If the motherboard is properly seated in the correct position, it will be securely attached to the chassis by the T-pins. (Refer to the layout for the locations of the mounting holes.)

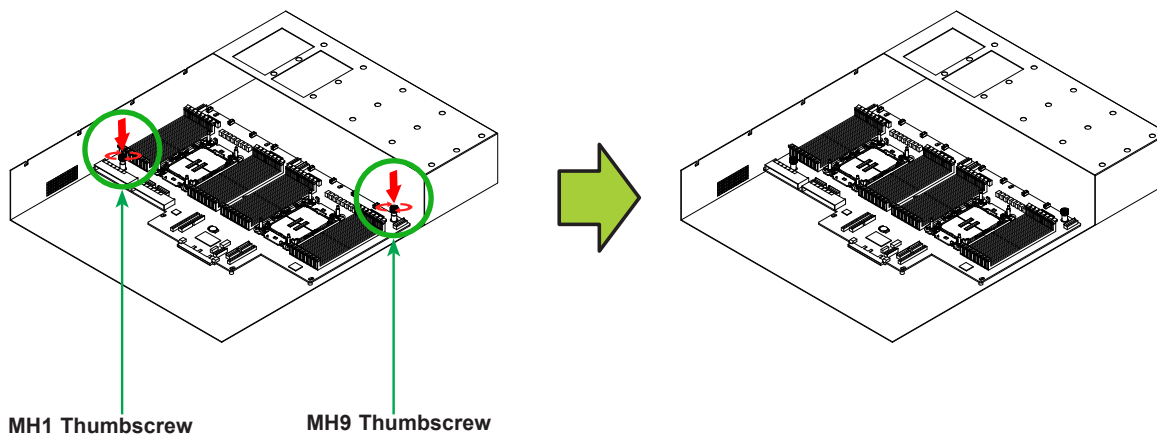
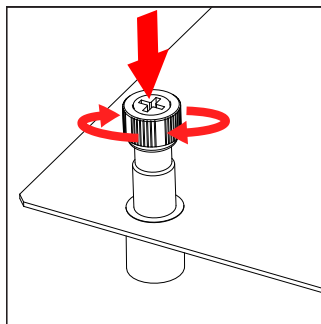

5. Turn the thumbscrews clockwise to securely tighten the motherboard to the chassis.

 **Note:** Images displayed in this user manual are for illustration only. Your chassis or components might look different from those shown.



 **Note:** Please refer to the layout for the locations of the mounting holes.

2.4 Memory Support and Installation

 **Note:** Check the Supermicro website for recommended memory modules.

 **Important:** Exercise extreme care when installing or removing DIMM modules to prevent any possible damage.

Memory Support

The X12DHM-6 supports up to 8TB 3DS LRDIMM/LRDIMM/3DS RDIMM/RDIMM DDR4 (288-pin) ECC memory with speeds of 3200/2933/2666 MHz in 32 memory slots and up to 8TB Intel Optane PMem 200 Series with speeds up to 3200 MHz. (See the notes below.)

 **Note 1:** Intel® Optane™ Persistent Memory (PMem) 200 Series is supported by the 3rd Gen Intel Xeon Scalable (83xx/63xx/53xx/4314 Series) Processors.

Note 2: Memory speed support depends on the processors used in the system.

DDR4 Memory Support for the 3rd Gen Intel Xeon Scalable Processors

DDR4 Memory Support for the 3rd Gen Intel Xeon Scalable Processors					
Type	Ranks Per DIMM & Data Width	DIMM Capacity (GB)		Speed (MT/s); Voltage (V); Slots Per Channel (SPC) and DIMMs Per Channel (DPC)	
				1DPC (1-DIMM Per Channel)	2DPC (2-DIMM Per Channel)
		8Gb	16Gb	1.2 V	1.2 V
RDIMM	SRx8	8GB	16GB	3200	3200
	SRx4	16GB	32GB		
	DRx8	16GB	32GB		
	DRx4	32GB	64GB		
RDIMM 3Ds	(4R/8R) X4	2H- 64 GB 4H-128 GB	2H- 128 GB 4H-256 GB		
LRDIMM	QRx4	64GB	128GB	3200	3200
LRDIMM - 3Ds	(4R/8R) X4	4H-128 GB	2H- 128 GB 4H-256 GB	3200	3200

Key Parameters for DIMM Configurations

Parameters	Possible Values
Number of Channels	8
Number of DIMMs per Channel	1DPC (1 DIMM Per Channel) or 2DPC (2 DIMMs Per Channel)
DIMM Type	RDIMM (w/ECC), 3DS RDIMM, LRDIMM, 3DS LRDIMM
DIMM Construction	non-3DS RDIMM Raw Cards: A/B (2Rx4), C (1Rx4), D (1Rx8), E (2Rx8) 3DS RDIMM Raw Cards: A/B (4Rx4) non-3DS LRDIMM Raw Cards: D/E (4Rx4) 3DS LRDIMM Raw Cards: A/B (8Rx4)

Memory Population Table (w/32 Slots)

DDR4 Memory Population Table for X12DP 32-DIMM Motherboards	
When 1 CPU is used:	Memory Population Sequence
1 CPU & 1 DIMM	CPU1: P1-DIMMA1
1 CPU & 2 DIMMs (Note)	CPU1: P1-DIMMA1/P1-DIMME1
1 CPU & 4 DIMMs (Note)	CPU1: P1-DIMMA1/P1-DIMME1/P1-DIMMC1/P1-DIMMG1
1 CPU & 6 DIMM	CPU1: P1-DIMMA1/P1-DIMME1/P1-DIMMC1/P1-DIMMG1/P1-DIMMB1/P1-DIMMF1
1 CPU & 8 DIMMs (Note)	CPU1: P1-DIMMA1/P1-DIMME1/P1-DIMMC1/P1-DIMMG1/P1-DIMMB1/P1-DIMMF1/P1-DIMMD1/P1-DIMMH1
1 CPU & 12 DIMMs (Note)	CPU1: P1-DIMMA1/P1-DIMME1/P1-DIMMC1/P1-DIMMG1/P1-DIMMB1/P1-DIMMF1/P1-DIMMA2/P1-DIMME2/ P1-DIMMC2/P1-DIMMG2/P1-DIMMB2/P1-DIMMF2
1 CPU & 16 DIMMs (Note)	CPU1: P1-DIMMA1/P1-DIMME1/P1-DIMMC1/P1-DIMMG1/P1-DIMMB1/P1-DIMMF1/P1-DIMMD1/P1-DIMMH1/ P1-DIMMA2/P1-DIMME2/P1-DIMMC2/P1-DIMMG2/P1-DIMMB2/P1-DIMMF2/P1-DIMMD2/P1-DIMMH2
When 2 CPUs are used	Memory Population Sequence
2 CPUs & 2 DIMMs (Note)	CPU1: P1-DIMMA1 CPU2: P2-DIMMA1
2 CPUs & 4 DIMMs (Note)	CPU1: P1-DIMMA1/P1-DIMME1 CPU2: P2-DIMMA1/P2-DIMME1
2 CPUs & 6 DIMMs	CPU1: P1-DIMMA1/P1-DIMME1/P1-DIMMC1/P1-DIMMG1 CPU2: P2-DIMMA1/P2-DIMME1
2 CPUs & 8 DIMMs (Note)	CPU1: P1-DIMMA1/P1-DIMME1/P1-DIMMC1/P1-DIMMG1 CPU2: P2-DIMMA1/P2-DIMME1/P2-DIMMC1/P2-DIMMG1
2 CPUs & 10 DIMMs	CPU1: P1-DIMMA1/P1-DIMME1/P1-DIMMC1/P1-DIMMG1/P1-DIMMB1/P1-DIMMF1 CPU2: P2-DIMMA1/P2-DIMME1/P2-DIMMC1/P2-DIMMG1
2 CPUs & 12 DIMMs (Note)	CPU1: P1-DIMMA1/P1-DIMME1/P1-DIMMC1/P1-DIMMG1/P1-DIMMB1/P1-DIMMF1 CPU2: P2-DIMMA1/P2-DIMME1/P2-DIMMC1/P2-DIMMG1/P2-DIMMB1/P2-DIMMF1
2 CPUs & 14 DIMMs	CPU1: P1-DIMMA1/P1-DIMME1/P1-DIMMC1/P1-DIMMG1/P1-DIMMB1/P1-DIMMF1/P1-DIMMD1/P1-DIMMH1 CPU2: P2-DIMMA1/P2-DIMME1/P2-DIMMC1/P2-DIMMG1/P2-DIMMB1/P2-DIMMF1
2 CPUs & 16 DIMMs (Note)	CPU1: P1-DIMMA1/P1-DIMME1/P1-DIMMC1/P1-DIMMG1/P1-DIMMB1/P1-DIMMF1/P1-DIMMD1/P1-DIMMH1 CPU2: P2-DIMMA1/P2-DIMME1/P2-DIMMC1/P2-DIMMG1/P2-DIMMB1/P2-DIMMF1/P2-DIMMD1/P2-DIMMH1
2 CPUs & 18 DIMMs	CPU1: P1-DIMMA1/P1-DIMME1/P1-DIMMC1/P1-DIMMG1/P1-DIMMB1/P1-DIMMF1/P1-DIMMA2/P1-DIMME2/ P1-DIMMC2/P1-DIMMG2/P1-DIMMB2/P1-DIMMF2 CPU2: P2-DIMMA1/P2-DIMME1/P2-DIMMC1/P2-DIMMG1/P2-DIMMB1/P2-DIMMF1
2 CPUs & 20 DIMMs	CPU1: P1-DIMMA1/P1-DIMME1/P1-DIMMC1/P1-DIMMG1/P1-DIMMB1/P1-DIMMF1/P1-DIMMA2/P1-DIMME2/ P1-DIMMC2/P1-DIMMG2/P1-DIMMB2/P1-DIMMF2 CPU2: P2-DIMMA1/P2-DIMME1/P2-DIMMC1/P2-DIMMG1/P2-DIMMB1/P2-DIMMF1/P2-DIMMD1/P2-DIMMH1
2 CPUs & 22 DIMMs	CPU1: P1-DIMMA1/P1-DIMME1/P1-DIMMC1/P1-DIMMG1/P1-DIMMB1/P1-DIMMF1/P1-DIMMD1/P1-DIMMH1/ P1-DIMMA2/P1-DIMME2/P1-DIMMC2/P1-DIMMG2/P1-DIMMB2/P1-DIMMF2/P1-DIMMD2/P1-DIMMH2 CPU2: P2-DIMMA1/P2-DIMME1/P2-DIMMC1/P2-DIMMG1/P2-DIMMB1/P2-DIMMF1
2 CPUs & 24 DIMMs (Note)	CPU1: P1-DIMMA1/P1-DIMME1/P1-DIMMC1/P1-DIMMG1/P1-DIMMB1/P1-DIMMF1/P1-DIMMD1/P1-DIMMH1/ P1-DIMMA2/P1-DIMME2/P1-DIMMC2/P1-DIMMG2/P1-DIMMB2/P1-DIMMF2/P1-DIMMD2/P1-DIMMH2 CPU2: P2-DIMMA1/P2-DIMME1/P2-DIMMC1/P2-DIMMG1/P2-DIMMB1/P2-DIMMF1/P2-DIMMD1/P2-DIMMH1
2 CPUs & 28 DIMMs	CPU1: P1-DIMMA1/P1-DIMME1/P1-DIMMC1/P1-DIMMG1/P1-DIMMB1/P1-DIMMF1/P1-DIMMD1/P1-DIMMH1/ P1-DIMMA2/P1-DIMME2/P1-DIMMC2/P1-DIMMG2/P1-DIMMB2/P1-DIMMF2/P1-DIMMD2/P1-DIMMH2 CPU2: P2-DIMMA1/P2-DIMME1/P2-DIMMC1/P2-DIMMG1/P2-DIMMB1/P2-DIMMF1/P2-DIMMD1/P2-DIMMH1/ P2-DIMMA2/P2-DIMME2/P2-DIMMC2/P2-DIMMG2
2 CPUs & 32 DIMMs (Note)	CPU1: P1-DIMMA1/P1-DIMME1/P1-DIMMC1/P1-DIMMG1/P1-DIMMB1/P1-DIMMF1/P1-DIMMD1/P1-DIMMH1/ P1-DIMMA2/P1-DIMME2/P1-DIMMC2/P1-DIMMG2/P1-DIMMB2/P1-DIMMF2/P1-DIMMD2/P1-DIMMH2 CPU2: P2-DIMMA1/P2-DIMME1/P2-DIMMC1/P2-DIMMG1/P2-DIMMB1/P2-DIMMF1/P2-DIMMD1/P2-DIMMH1/ P2-DIMMA2/P2-DIMME2/P2-DIMMC2/P2-DIMMG2/P2-DIMMB2/P2-DIMMF2/P2-DIMMD2/P2-DIMMH2

 **Note:** This memory configuration is recommended by Supermicro for optimal memory performance. Please use this configuration to maximize your memory performance.

PMem 200 Series Population table for X12DHM-6 Motherboards (w/32 Slots)

 **Note:** Intel® Optane™ Persistent Memory (PMem) 200 Series is supported by the 3rd Gen Intel Xeon Scalable (83xx/63xx/53xx/4314 Series) Processors.

PMem 200 Series Population Table for X12DP 32-DIMM Motherboards (within 1 CPU socket)																				
DDR4+ PMem	Mode	AD Interleave	P1-DIMMF1	P1-DIMMF2	P1-DIMME1	P1-DIMME2	P1-DIMMH1	P1-DIMMH2	P1-DIMMG1	P1-DIMMG2	P1-DIMMC2	P1-DIMMC1	P1-DIMMD2	P1-DIMMD1	P1-DIMMA2	P1-DIMMA1	P1-DIMMB2	P1-DIMMB1		
4+4	AD MM	One - x4	PMem	-	DDR4	-	PMem	-	DDR4	-	-	DDR4	-	PMem	-	DDR4	-	PMem		
		One - x4	DDR4	-	PMem	-	DDR4	-	PMem	-	-	PMem	-	DDR4	-	PMem	-	DDR4		
6+1	AD	One - x1	DDR4	-	DDR4	-	-	-	DDR4	-	-	DDR4	-	PMem	-	DDR4	-	DDR4		
			-	-	DDR4	-	DDR4	-	DDR4	-	-	DDR4	-	DDR4	-	DDR4	-	PMem		
			DDR4	-	DDR4	-	PMem	-	DDR4	-	DDR4	-	-	DDR4	-	-	-	DDR4	-	DDR4
			PMem	-	DDR4	-	DDR4	-	DDR4	-	DDR4	-	-	DDR4	-	DDR4	-	DDR4	-	-
			DDR4	-	DDR4	-	DDR4	-	-	-	-	-	PMem	-	DDR4	-	DDR4	-	DDR4	
			DDR4	-	-	-	DDR4	-	DDR4	-	DDR4	-	-	DDR4	-	DDR4	-	PMem	-	DDR4
			DDR4	-	DDR4	-	DDR4	-	PMem	-	-	-	-	-	DDR4	-	DDR4	-	DDR4	
			DDR4	-	PMem	-	DDR4	-	DDR4	-	DDR4	-	-	DDR4	-	DDR4	-	-	-	DDR4
8+1	AD	One - x1	DDR4	-	DDR4	-	DDR4	-	DDR4	-	-	DDR4	-	DDR4	PMem	DDR4	-	DDR4		
			DDR4	-	DDR4	-	DDR4	-	DDR4	-	PMem	DDR4	-	DDR4	-	DDR4	-	DDR4		
			DDR4	-	DDR4	PMem	DDR4	-	DDR4	-	-	DDR4	-	DDR4	-	DDR4	-	DDR4		
			DDR4	-	DDR4	-	DDR4	-	DDR4	PMem	-	DDR4	-	DDR4	-	DDR4	-	DDR4		
			DDR4	-	DDR4	-	DDR4	-	DDR4	-	-	-	DDR4	PMem	DDR4	-	DDR4	-	DDR4	
			DDR4	-	DDR4	-	DDR4	-	DDR4	-	DDR4	-	-	DDR4	-	DDR4	-	DDR4	PMem	DDR4
			DDR4	PMem	DDR4	-	DDR4	-	DDR4	-	-	-	DDR4	-	DDR4	-	DDR4	-	DDR4	
			DDR4	-	DDR4	-	DDR4	PMem	DDR4	-	-	-	DDR4	-	DDR4	-	DDR4	-	DDR4	
8+4	AD MM	One - x4	DDR4	-	DDR4	PMem	DDR4	-	DDR4	PMem	PMem	DDR4	-	DDR4	PMem	DDR4	-	DDR4		
		Two - x2	DDR4	-	DDR4	PMem	DDR4	PMem	DDR4	-	-	DDR4	PMem	DDR4	PMem	DDR4	-	DDR4		
		Two - x2	DDR4	PMem	DDR4	-	DDR4	-	DDR4	PMem	PMem	DDR4	-	DDR4	-	DDR4	PMem	DDR4		
		One - x4	DDR4	PMem	DDR4	-	DDR4	PMem	DDR4	-	-	DDR4	PMem	DDR4	-	DDR4	PMem	DDR4		
8+8	AD, MM,	One - x8	DDR4	PMem	DDR4	PMem	DDR4	PMem	DDR4	PMem	PMem	DDR4	PMem	DDR4	PMem	DDR4	PMem	DDR4		
12+2	AD	One - x2	PMem	-	DDR4	DDR4	DDR4	DDR4	DDR4	DDR4	DDR4	DDR4	DDR4	DDR4	DDR4	DDR4	-	PMem		
			DDR4	DDR4	DDR4	DDR4	PMem	-	DDR4	DDR4	DDR4	DDR4	-	PMem	DDR4	DDR4	DDR4	DDR4		
			DDR4	DDR4	PMem	-	DDR4	DDR4	DDR4	DDR4	DDR4	DDR4	DDR4	DDR4	-	PMem	DDR4	DDR4		
			DDR4	DDR4	DDR4	DDR4	DDR4	DDR4	PMem	-	-	PMem	DDR4	DDR4	DDR4	DDR4	DDR4	DDR4		

Legend (for the table above)	
DDR4 Type and Capacity	
DDR4	See Validation Matrix (DDR4 DIMMs validated with PMem)
Capacity	
PMem	Any Capacity (Uniformly for all channels for a given configuration)

- Mode definitions: AD = App Direct Mode, MM = Memory Mode.
- No mixing of PMem and NVDIMMs within the platform.
- For MM, NM/FM ratio is between 1:4 and 1:16. (NM = Near Memory (DRAM); FM = Far Memory (PMem)).
- Matrix targets configs for optimized PMem to DRAM cache ratio in MM mode.
- For each individual population, different PMem rearrangements among channels are permitted so long as the configuration doesn't break X12DP Memory population rules.
- Ensure the same DDR4 DIMM type and capacity are used for each DDR4 + PMem population.
- If the system detects an unvalidated configuration, then the system issues a BIOS warning. The CLI functionality is limited in non-POR configurations, and select commands will not be supported.

Validation Matrix (DDR4 DIMMS with PMem 200 Series)			
DIMM Type	Ranks Per DIMM & Data Width (Stack)	DIMM Capacity (GB)	
		DRAM Density	
		8Gb	16Gb
RDIMM (up to 3200)	1Rx8	N/A	N/A
	1Rx4	16GB	32GB
	1Rx8	16GB	32GB
	1Rx4	32GB	64GB
RDIMM 3DS (up to 3200)	4Rx4 (2H)	N/A	128GB
	8Rx4 (4H)	NA	256GB
LRDIMM (up to 3200)	4Rx4	64GB	128GB
LRDIMM 3DS (up to 3200)	4Rx4 (2H)	N/A	N/A
	8Rx4 (4H)	128GB	256GB

DIMM Installation

1. Insert the desired number of DIMMs into the memory slots based on the recommended DIMM population table in the previous section.
2. Push the release tabs outwards on both ends of the DIMM slot to unlock it.

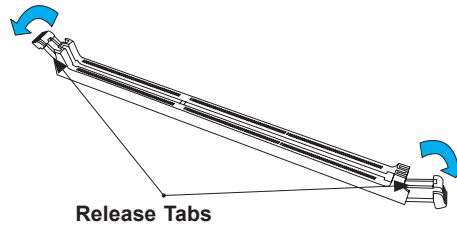
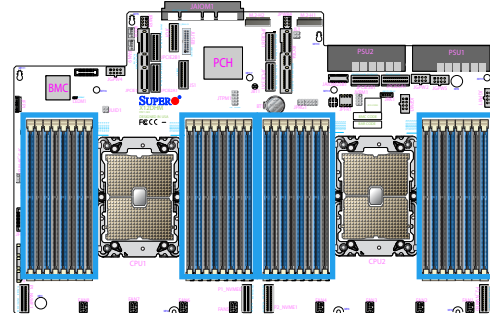

3. Align the key of the DIMM module with the receptive point on the memory slot.

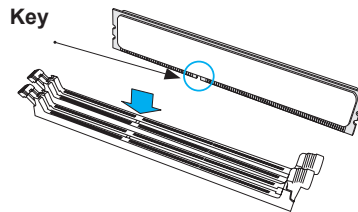

4. Align the notches on both ends of the module against the receptive points on the ends of the slot.

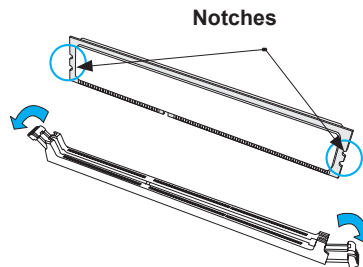

5. Push both ends of the module straight down into the slot until the module snaps into place.

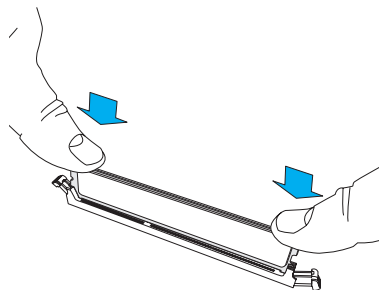

6. Press the release tabs to the lock positions to secure the DIMM module into the slot.

DIMM Removal

Press both release tabs on the ends of the DIMM module to unlock it. Once the DIMM module is loosened, remove it from the memory slot.

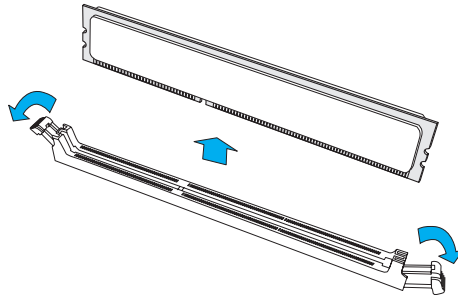

Warning! Please do not use excessive force when pressing the release tabs on the ends of the DIMM socket to avoid causing any damage to the DIMM module or the DIMM socket. Please handle DIMM modules with care. Carefully follow all the instructions given on Page 1 of this chapter to avoid ESD-related damages done to your memory modules or components.

2.5 I/O Ports

The low-profile slimSAS I/O connector, located at JIO1, is used to connect the motherboard to an I/O mezzanine board to provide VGA/COM/BMC connections.

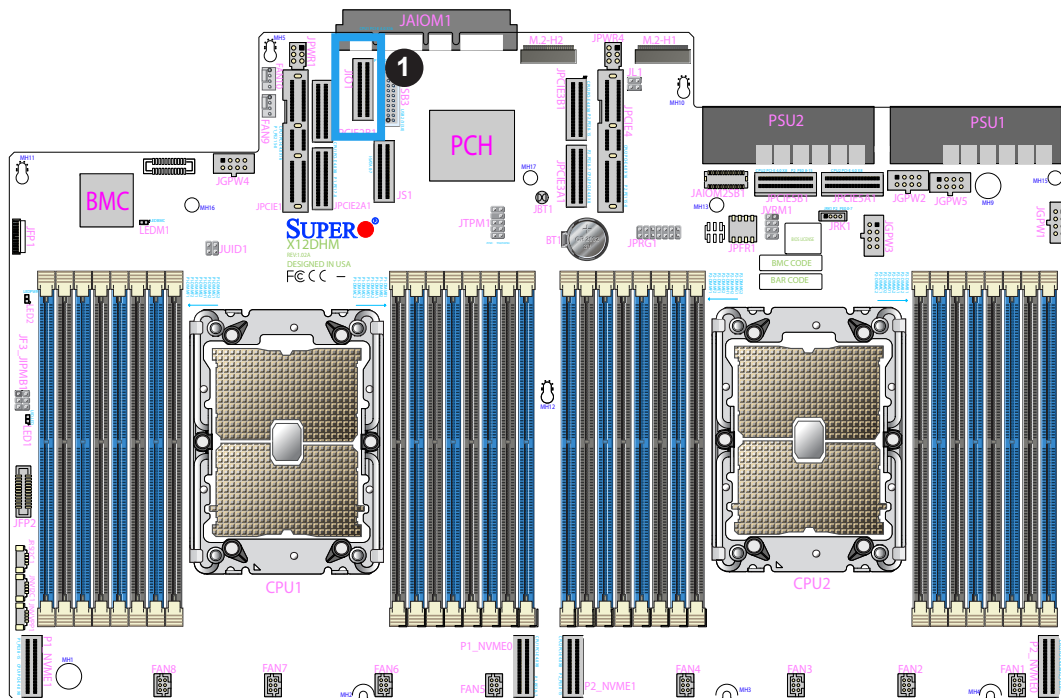

1. JIO1

2.6 Front Control Panel

The front control panel header (JFP1) contains header pins for various buttons and indicators that are normally located on a control panel at the front of the chassis. These connectors are designed specifically for use with Supermicro chassis. See the figure below for the descriptions of the front control panel buttons and LED indicators.

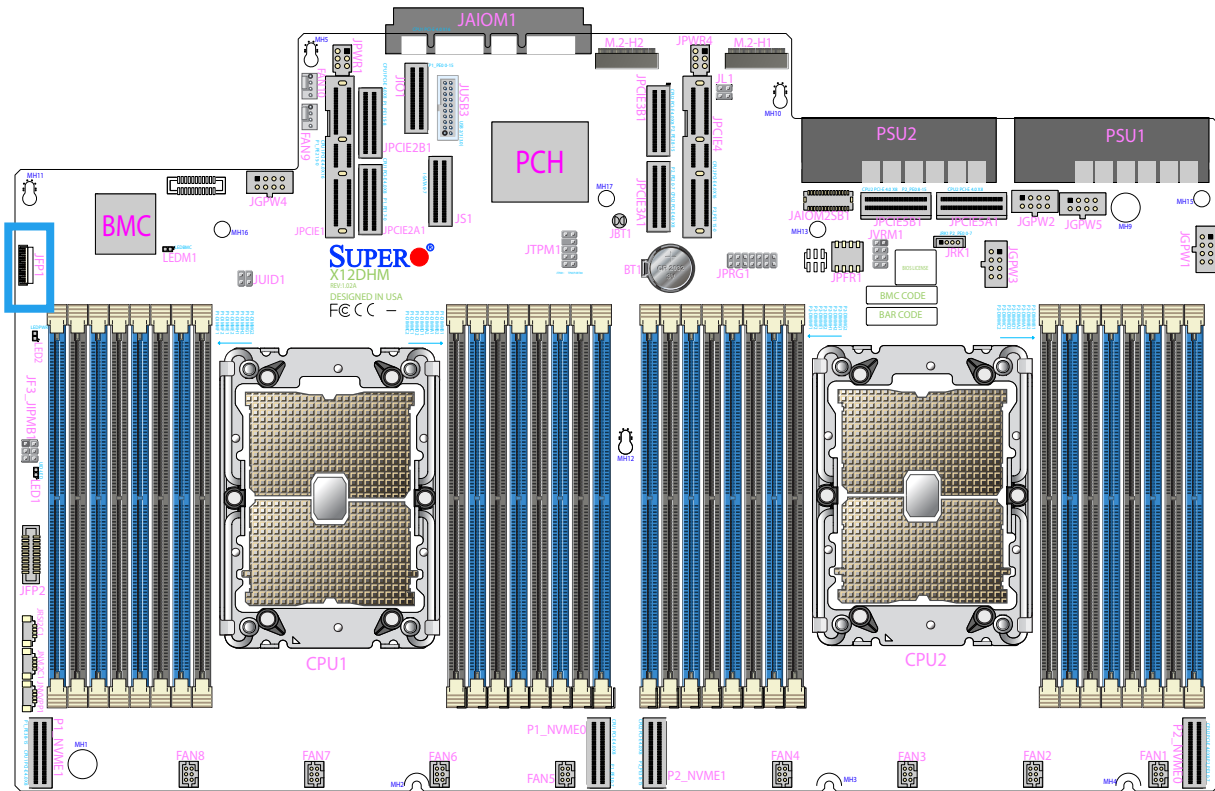

JFP1

1	Power Button
2	Reset/UID Button
3	UID LED_N
4	Fail LED_N (OH/FF/PF)
5	LAN-2 Activity LED
6	LAN-1 Activity LED (Aggregate all LAN)
7	HDD Activity LED
8	Standby LED_N
9	Power/RoT LED_N
10	P3V3_STBY
11	Ground
12	I2C Data
13	I2C Clock
14	Ground
15	Power Fail LED_P
16	P5V_USB
17	P5V_USB
18	P5V_USB
19	Power Fail LED_N
20	Ground

JFP1 Header Pins

Front Control Panel LEDs

Front Control Panel (JFP1) LED Indicators						
Event	Power (LED1)	HDD (LED2)	LAN (LED3/4)	UID (LED5)	Information (LED5)	Power Fail (LED6)
Power On	Solid On					
HDD Activity		Blinking				
LAN Activity			Blinking			
Overheat					Solid On	
Fan Fail					Blinking @1Hz	
Power Fail					Blinking @1/4Hz	Solid On
Local UID On				Solid On		
Remote UID On				Blinking 1Hz		
Checking	BMC/BIOS Blinking @4HZ					
Recovering/Updating	BMC Blinking @4HZ BMC 2 Blinks @4Hz, 1 Pause @2Hz (on-on-off-off)			BIOS/BMC Blinking @10Hz		
Flash Not Detected or Golden Image Check Failed	BMC/BIOS Blinking @1HZ					
CPLD Recovery Mode				Blinking @10Hz (MB UID LED)	Blinking @10Hz (FP Red LED)	

Power On & BMC/BIOS Status LED Button

The Power On and BMC/BIOS Status LED button is located on pin 1 of JFP1.

Power Button LED States	
Status	Event
Green: solid on	System power on
BMC/BIOS blinking green @ 4Hz	BMC/BIOS checking
BIOS blinking green @ 4Hz	BIOS recovery/update in progress
BMC blinking red x2 (2 blinks red) @ 4Hz, 1 pause @ 2Hz (on-on-off-off)	BMC recovery/update in progress
BMC/BIOS blinking green @ 1Hz	Flash not detected or golden image checking failure

Reset Button/UID Button

The UID Switch connection is located on pin 2 of JFP1. The UID switch in conjunction with the jumper JUID1 is used for a chassis that supports a front UID switch. Setting JUID1 to pin 3-4 will configure the front panel button as a reset button.

JFP1

1	○	Power Button	1
2	○	Reset/UID Button	2
3	○	UID LED_N	
4	○	Fail LED_N (OH/FF/PF)	
5	○	LAN-2 Activity LED	
6	○	LAN-1 Activity LED (Aggregate all LAN)	
7	○	HDD Activity LED	
8	○	Standby LED_N	
9	○	Power/RoT LED_N	
10	○	P3V3_STBY	
11	○	Ground	
12	○	I2C Data	
13	○	I2C Clock	
14	○	Ground	
15	○	Power Fail LED_P	
16	○	P5V_USB	
17	○	P5V_USB	
18	○	P5V_USB	
19	○	Power Fail LED_N	
20	○	Ground	

1. Power Button
2. Reset/UID Button

Power Fail LED

The Power Fail LED connection is located on pin 19 of JFP1. When this LED turns solid red, it indicates a power failure.

UID LED

The unit identifier LED connection is located on pin 3 of JFP1.

Information LED (OH/FF/PF)

The Information LED (OH/Fan Fail/PWR Fail LED) connection is located on pin 4 of JFP1. The LED provides warnings of overheat, power failure, or fan failure. Refer to the tables below for more information.

Information LED (OH/Fan Fail/PWR Fail) LED States	
Status	Description
Solid red (on)	An overheat condition has occurred.
Blinking red (1Hz)	Fan failure: check for an inoperative fan.
Blinking red (0.25Hz)	Power failure: check for a non-operational power supply
Blinking red (10Hz) (FP red LED)	CPLD recovery mode error(s)
Solid blue	Local UID is activated. Use this function to locate a unit in a rack mount environment that might be in need of service.
Blinking blue (1Hz)	Remote UID is on. Use this function to identify a unit from a remote location that might be in need of service.
BIOS/BMC blinking blue (10Hz)	BIOS/BMC: recovery and/or update in progress
Red Info LED blinking (10Hz) and MB UID LED blue blinking (10Hz)	CPLD: recovery and/or update in progress

JFP1

1	<input type="radio"/>	Power Button
2	<input type="radio"/>	Reset/UID Button
3	<input type="radio"/>	UID LED_N
4	<input type="radio"/>	Fail LED_N (OH/FF/PF)
5	<input type="radio"/>	LAN-2 Activity LED
6	<input type="radio"/>	LAN-1 Activity LED (Aggregate all LAN)
7	<input type="radio"/>	HDD Activity LED
8	<input type="radio"/>	Standby LED_N
9	<input type="radio"/>	Power/RoT LED_N
10	<input type="radio"/>	P3V3_STBY
11	<input type="radio"/>	Ground
12	<input type="radio"/>	I2C Data
13	<input type="radio"/>	I2C Clock
14	<input type="radio"/>	Ground
15	<input type="radio"/>	Power Fail LED_P
16	<input type="radio"/>	P5V_USB
17	<input type="radio"/>	P5V_USB
18	<input type="radio"/>	P5V_USB
19	<input type="radio"/>	Power Fail LED_N
20	<input type="radio"/>	Ground

1. Power Fail LED
2. Information LED
3. UID LED

LAN1/LAN2 (NIC1/NIC2)

The NIC (Network Interface Controller) LED connection for LAN port 1 is located on pin 6 of JFP1, and LAN port 2 is on pin 5. Refer to the tables below for more information.

LAN1/LAN2 LED LED States	
Color	State
NIC 2: Blinking green	LAN 2: Active
NIC 1: Blinking green	LAN 1: Active

JFP1

1	○	Power Button
2	○	Reset/UID Button
3	○	UID LED_N
4	○	Fail LED_N (OH/FF/PF)
5	○	LAN-2 Activity LED
6	○	LAN-1 Activity LED (Aggregate all LAN)
7	○	HDD Activity LED
8	○	Standby LED_N
9	○	Power/RoT LED_N
10	○	P3V3_STBY
11	○	Ground
12	○	I2C Data
13	○	I2C Clock
14	○	Ground
15	○	Power Fail LED_P
16	○	P5V_USB
17	○	P5V_USB
18	○	P5V_USB
19	○	Power Fail LED_N
20	○	Ground

- 1. LAN 2 Activity LED
- 2. LAN 1 Activity LED

FP Power LED

The Front Panel Power LED connection is located on pin 9 of JFP1.

HDD Activity LED

The HDD activity LED connection is located on pin 7 of JFP1. When this LED is blinking green, it indicates HDD is active. Refer to the tables below for more information.

HDD LED LED State	
Color	State
Blinking Green	HDD Active

JFP1

1	○	Power Button
2	○	Reset/UID Button
3	○	UID LED_N
4	○	Fail LED_N (OH/FF/PF)
5	○	LAN-2 Activity LED
6	○	LAN-1 Activity LED (Aggregate all LAN)
7	○	HDD Activity LED 2
8	○	Standby LED_N
9	○	Power/RoT LED_N 1
10	○	P3V3_STBY
11	○	Ground
12	○	I2C Data
13	○	I2C Clock
14	○	Ground
15	○	Power Fail LED_P
16	○	P5V_USB
17	○	P5V_USB
18	○	P5V_USB
19	○	Power Fail LED_N
20	○	Ground

1. Front Panel Power LED
2. HDD Activity LED

2.7 Connectors

Power Connections

Power Supply Connectors

Two power supply connectors are located at PSU1 and PSU2. Connect the 8-pin 12V DC power connectors (JGPW1/JGPW2/JGPW3/JGPW4/JGPW5) to the GPUs and backplane devices to provide adequate power to your system.

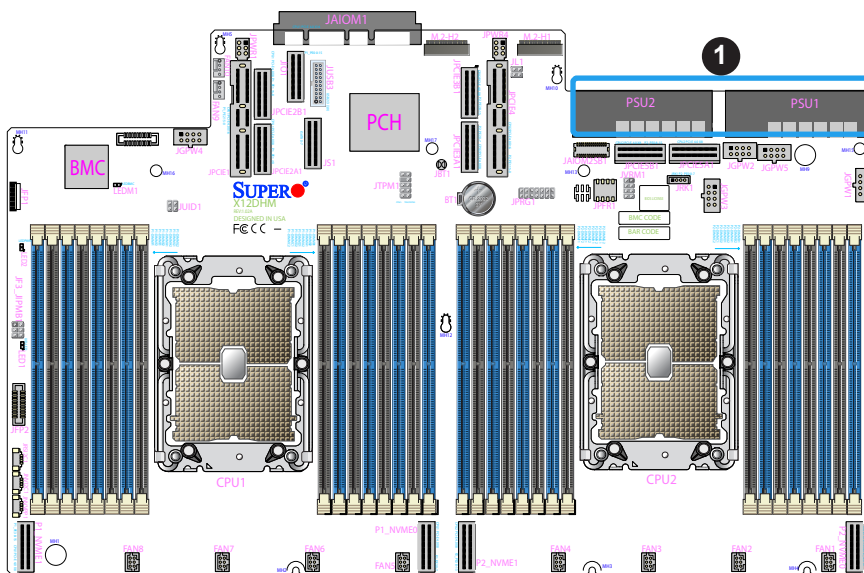

1. Power Supply Unit Connectors (PSU1/PSU2)

VGA Connections

The VGA header is located at JFP2 on the motherboard. These VGA connections provide analog interface support between the computer and the video displays. Refer to the layout below for the locations of VGA connections.

1. VGA connector (JFP2)

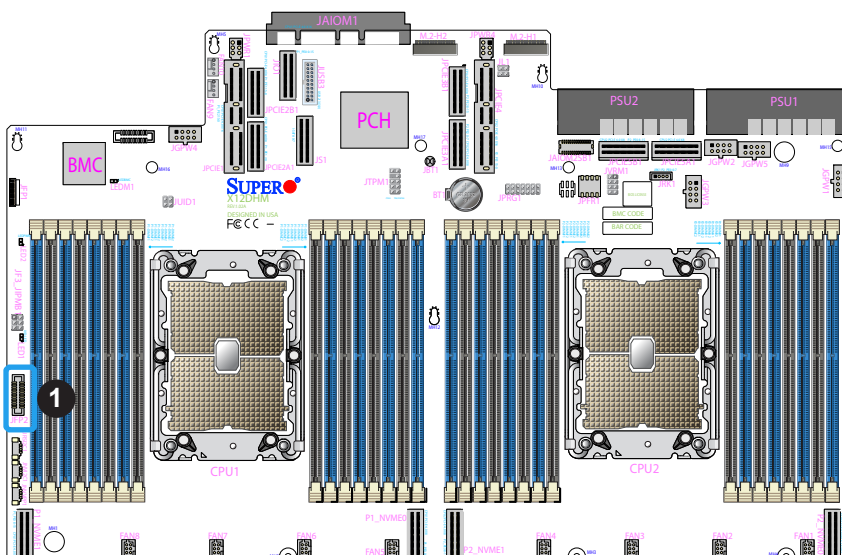

8-Pin Power Connectors

JGPW1/JGPW2/JGPW3/JGPW4/JGPW5 are 8-pin 12V DC power outputs connectors for the GPUs and backplane devices. Refer to the table below for pin definitions.

8-pin Power Pin Definitions	
Pin#	Definition
1 - 4	Ground
5 - 8	+12V

Required Connection

Other Power Connectors

JPWR1/JPWR4 are power output connectors, which are part of the 4C+ connectors and provide power to the PCIe slots.

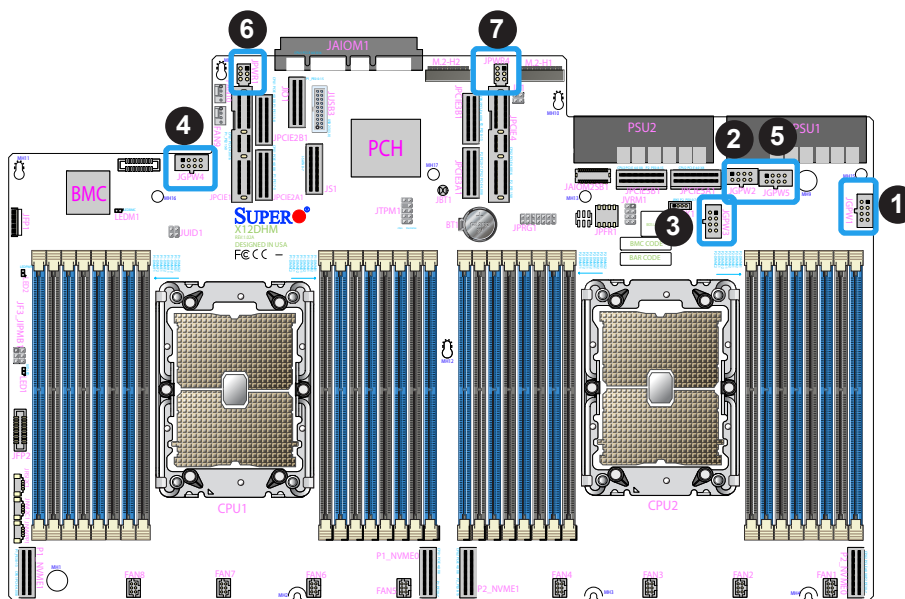

1. JGPW1
2. JGPW2
3. JGPW3
4. JGPW4
5. JGPW5
6. JPWR1
7. JPWR4

Universal Serial Bus (USB) Ports and Headers

A USB header is located at JUSB3 on the motherboard. This USB header supports two USB 3.0 connections.

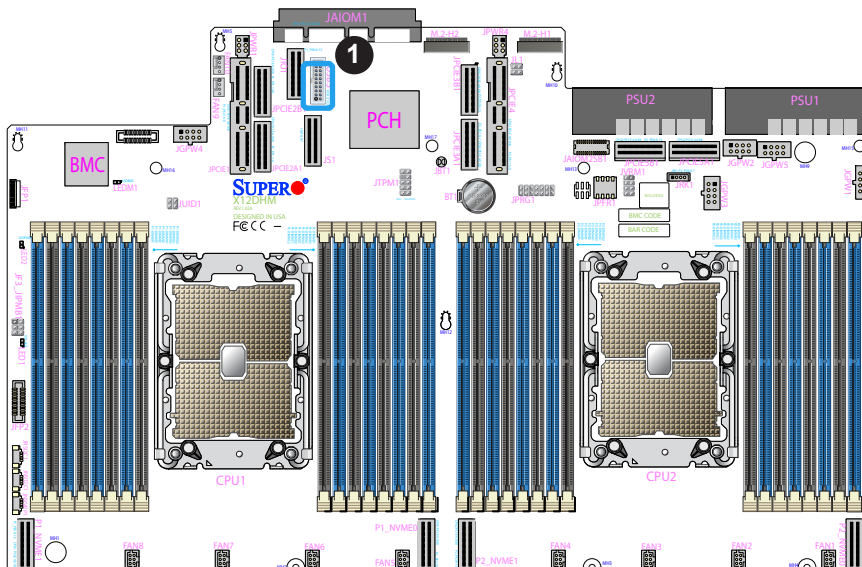

1. JUSB3

Headers

Fan Headers

There are eight 6-pin fan headers (FAN1 ~ FAN8) and two 4-pin fan headers (FAN9 ~ FAN10) on the motherboard. All these fan headers are backwards compatible with the traditional 3-pin fans. However, fan speed control is available by Thermal Management via the BMC interface. Refer to the table below for pin definitions.

6-pin Fan Header Pin Definitions	
Pin#	Definition
1	Ground
2	3A/+12V
3	Tachometer
4	PWM_Control
5	3A/12V
6	Ground

4-pin Fan Header Pin Definitions	
Pin#	Definition
1	Ground
2	2.5A/+12V
3	Tachometer
4	PWM_Control

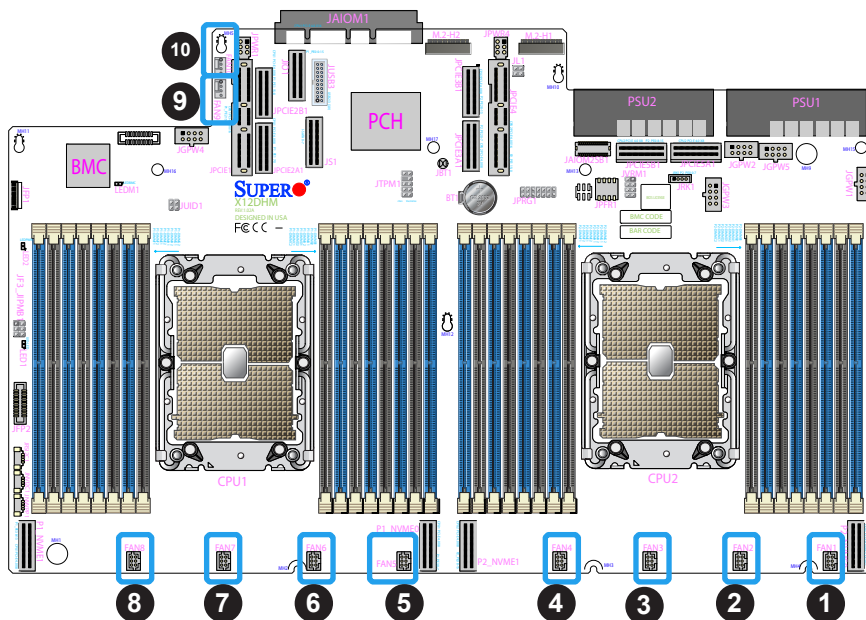

1. FAN1
2. FAN2
3. FAN3
4. FAN2
5. FAN5
6. FAN6
8. FAN8
9. FAN9
10. FAN10

TPM/Port 80 Header

A Trusted Platform Module (JTPM1)/ Port 80 header is located at JTPM1 to provide TPM support and Port 80 connection. Use this header to enhance system performance and data security. Refer to the table below for pin definitions. Please go to the following link for more information on the TPM: <http://www.supermicro.com/manuals/other/TPM.pdf>.

Trusted Platform Module Header Pin Definitions			
Pin#	Definition	Pin#	Definition
1	+3.3V	2	SPI_CS#
3	RESET#	4	SPI_MISO
5	SPI_CLK	6	GND
7	SPI_MOSI	8	NC
9	+3.3V Stdby	10	SPI_IRQ#

1. TPM Header

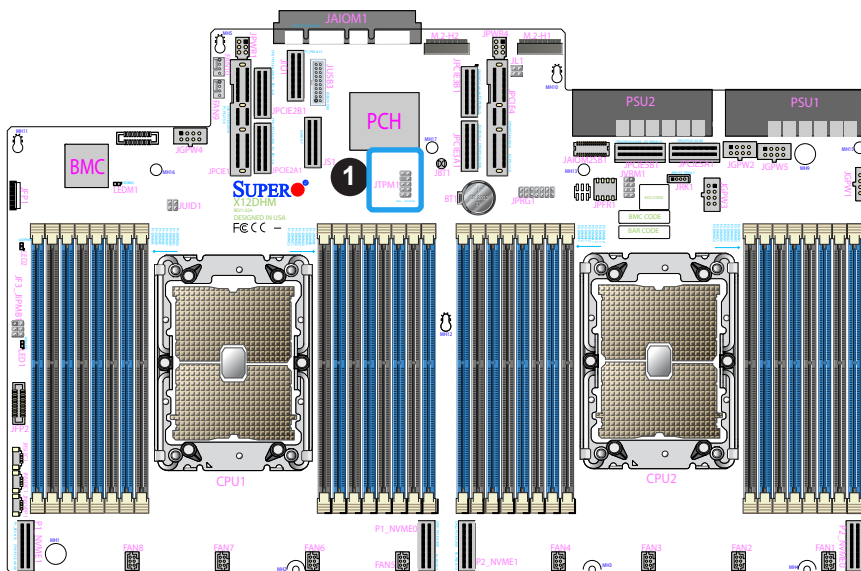

Chassis Intrusion

A Chassis Intrusion header is located at JL1 on the motherboard. Attach the appropriate cable from the chassis to inform you when the chassis is opened. Refer to the table below for pin definitions.

6-pin BMC External I²C Header

A System Management Bus header for BMC 2.0 is located at JF3_JIPMB1. Connect the appropriate cable here to use the IPMB I²C connection on your system. Refer to the table below for pin definitions.

1. Chassis Intrusion (JL1)
2. BMC External Header (JF3_JIPMB1)

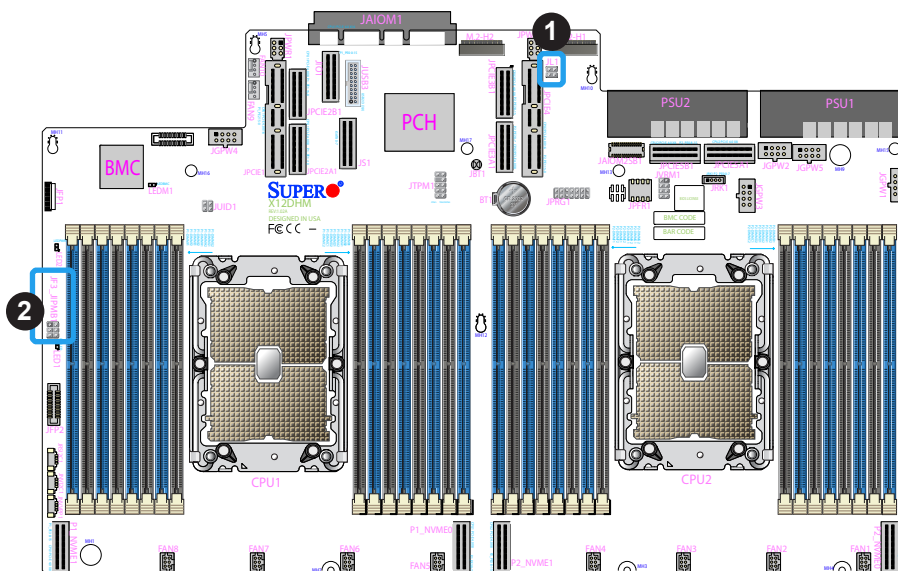

M.2 Slots

The X12DHM-6 motherboard has two PCIe 3.0 hybrid and NVMe or SATA M.2 slots (M.2-H1, M.2-H2). M.2 allows for a variety of card sizes, increased functionality, and spatial efficiency. The M.2 slot on the motherboard supports PCIe 3.0 x2 or SATA 3.0 devices in the 2280 and 22110 form factors.

NVMe SMBus Headers

NVMe SMBus (I²C) header (JNVI2C1), used for PCIe SMBus clock and data connections, provides hot-plug support via a dedicated SMBus interface. This feature is only available for a Supermicro complete system with an SMCI-proprietary NVMe add-on card and a proper cable installed. See the table below for pin definitions.

NVMe SMBus Header Pin Definitions	
Pin#	Definition
1	Data
2	Ground
3	Clock
4	VCCIO

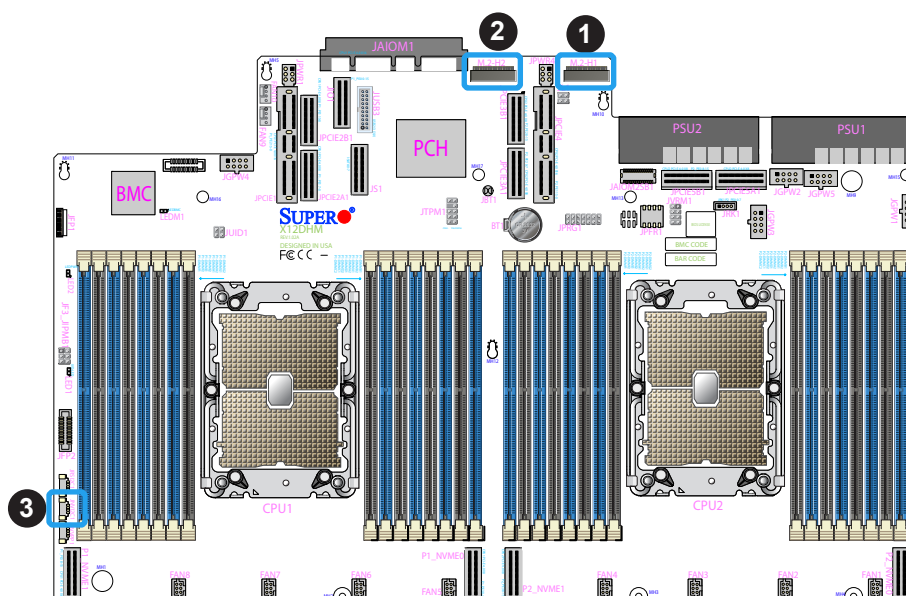

1. M.2-H1
2. M.2-H2
3. JNVI2C1

NVMe Connectors

Four NVMe connectors (P1_NVME0, P1_NVME1, P2_NVME0, P2_NVME1) provide onboard NVMe connections. Use these NVMe connectors to attach high-speed PCIe storage devices.

Note: When installing an NVMe device on a motherboard, please be sure to connect the first NVMe port first (P1_NVME0/P2_NVME0) for your system to work properly.

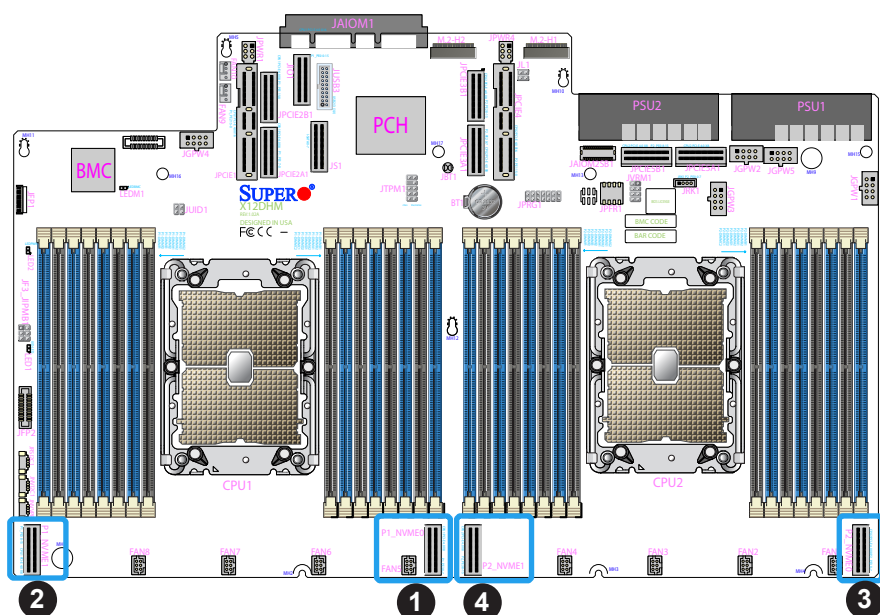

1. NVMe slot 1 (P1_NVME0)
2. NVMe slot 2 (P1_NVME1)
3. NVMe slot 3 (P2_NVME0)
4. NVMe slot 4 (P2_NVME1)

I-SATA 3.0 Ports

The X12DHM-6 has an I-SATA 3.0 header (JS1) with support for eight I-SATA ports (I-SATA0~7) on the motherboard. These SATA ports are supported by the Intel C621A chipset. Please refer to the layout below for the location of JS1.

1. JS1 (I-SATA0~7)

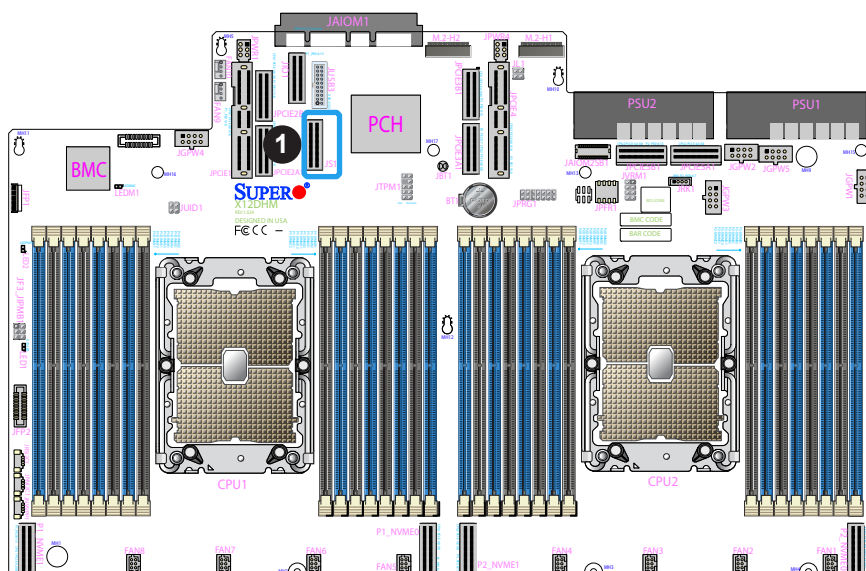

VROC RAID Key Header

A VROC RAID Key header is located at JRK1 on the motherboard. Install a VROC RAID Key on JRK1 for NVMe RAID support as shown in the illustration below. Please refer to the layout below for the location of JRK1.

Intel VROC Key Pin Definitions	
Pin#	Definition
1	Ground
2	3.3V Standby
3	Ground
4	PCH RAID Key

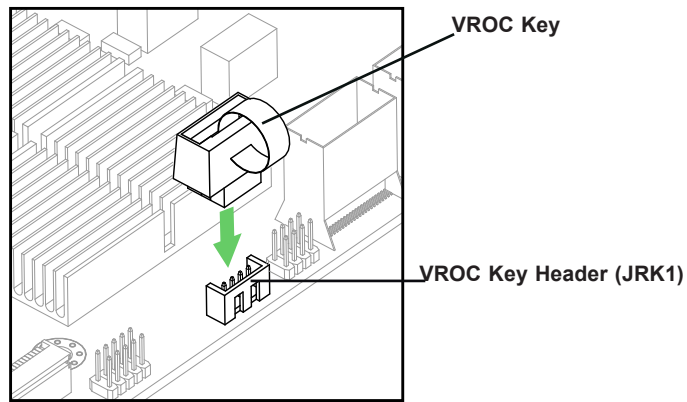

 **Note:** The graphics contained in this user's manual are for illustration only. The components installed in your system may or may not look exactly the same as the graphics shown in the manual.

1. VROC RAID Key (JRK1)

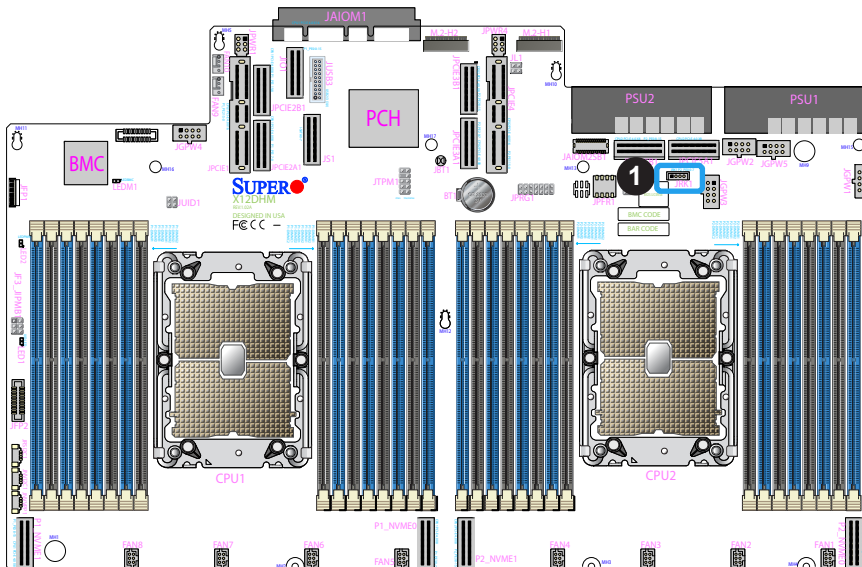

SMBus Header for Riser Card

The SMBus Header for the riser card is located at JRSI2C1 on the motherboard. Please refer to the layout below for the location of JRSI2C1.

1. JRSI2C1

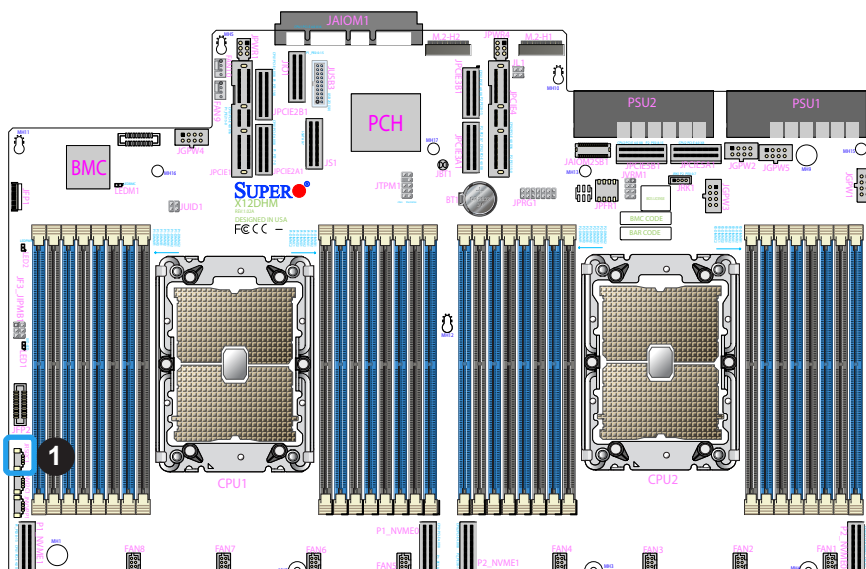

CPU VPP Bus Header for Backplane NVMe Riser Card Device

The CPU VPP Bus header for the riser card is located at JNVVPP1 on the motherboard. Please refer to the layout below for the location of JNVVPP1.

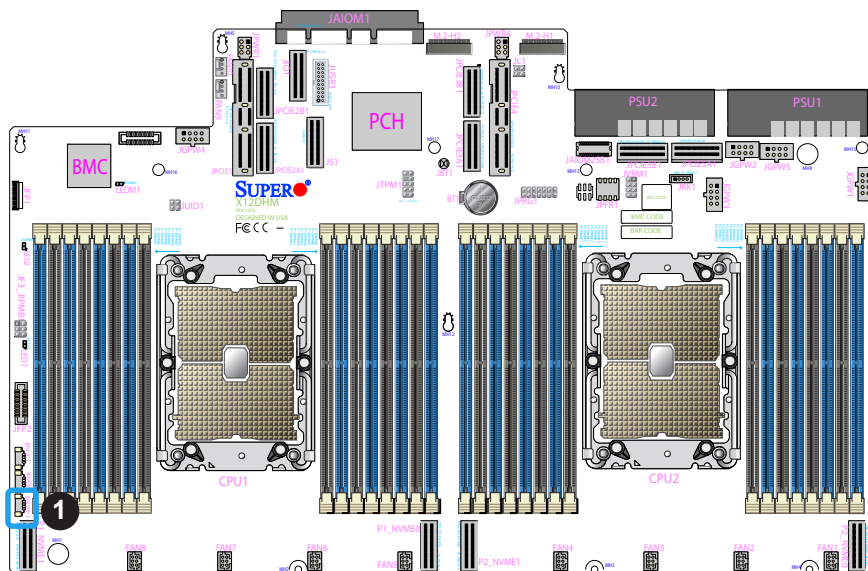

1. JNVVPP1

2.8 Jumper Settings

How Jumpers Work

To modify the operation of the motherboard, jumpers can be used to choose between optional settings. Jumpers create shorts between two pins to change the function of the connector. Pin 1 is identified with a square solder pad on the printed circuit board. See the diagram below for an example of jumping pins 1 and 2. Refer to the motherboard layout page for jumper locations.

 **Note:** On two-pin jumpers, "Closed" means the jumper is on, and "Open" means the jumper is off the pins.

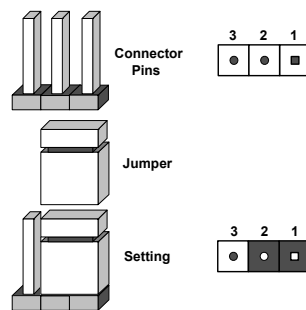

CMOS Clear

JBT1 is used to clear CMOS, which will also clear any passwords. Instead of pins, this jumper consists of contact pads to prevent accidentally clearing the contents of CMOS.

To Clear CMOS

1. First power down the system and unplug the power cord(s).
2. Remove the cover of the chassis to access the motherboard.
3. Remove the onboard battery from the motherboard.
4. Short the CMOS pads with a metal object such as a small screwdriver for at least four seconds.
5. Remove the screwdriver (or shorting device), and reinstall the battery to the proper location
6. Replace the cover, reconnect the power cord(s), and power on the system.

 **Note:** Clearing CMOS will also clear all passwords.



JTAG Port for Complex Programmable Logic Device (CPLD)

Use this jumper to enable the JTAG port for the Complex Programmable Logic Device (JPFR1) on the motherboard. Setting JPFR1 to pin 1-2 will enable the CPLD JTAG port. Please refer to the table below for pin definitions.

JPFR1 Pin Definitions			
Pin#	Definition	Pin#	Definitin
1	EN_JTAG	2	P3V3_STBY
3	PFR_FORCE_ON_N	4	Ground
5	PFR_FORCE_RECOVERY_N	6	Ground
7	ME_RCVR_N	8	Ground

1. JPFR1

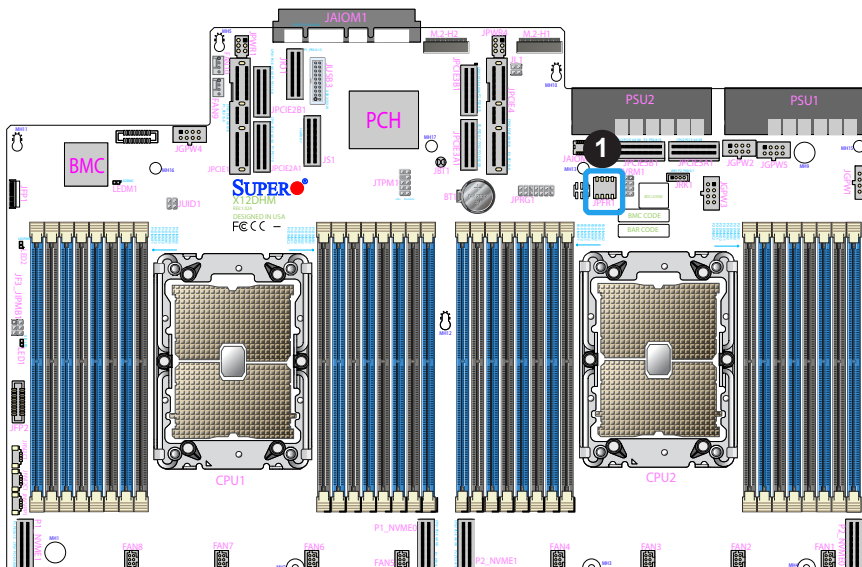

Reset Button/UID Button

The UID button in conjunction with the jumper JUID1 is used for a chassis that supports a front UID button. Setting JUID1 to pin 3-4 will configure the front UID button as a reset button.

1. JUID1

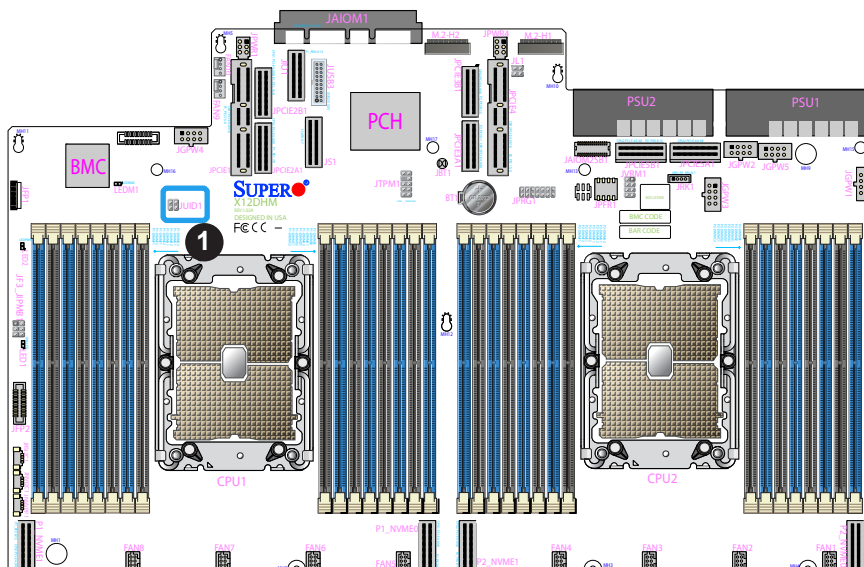

VRM SMBus Jumper

JVRM1 is a voltage regulator module (VRM) SMBus jumper. Use this jumper to configure the CPU and memory VRM controllers. Setting JVRM1 to pin 1-3 and 2-4 will configure BMC as the VRM controller. Setting JVRM1 to pin 3-5 and 4-6 will configure the PCH as the VRM controller. Please refer to the table below for pin definitions.

JVRM1 Pin Definitions			
Pin#	Definition	Pin#	Definitin
1	SMBDAT_VRM	2	SMBCLK_VRM
3	SDA_VRM	4	SCL_VRM
5	PCH_SMBDAT	6	PCH_SMBCLK
7	Ground	8	Ground

1. JVRM1

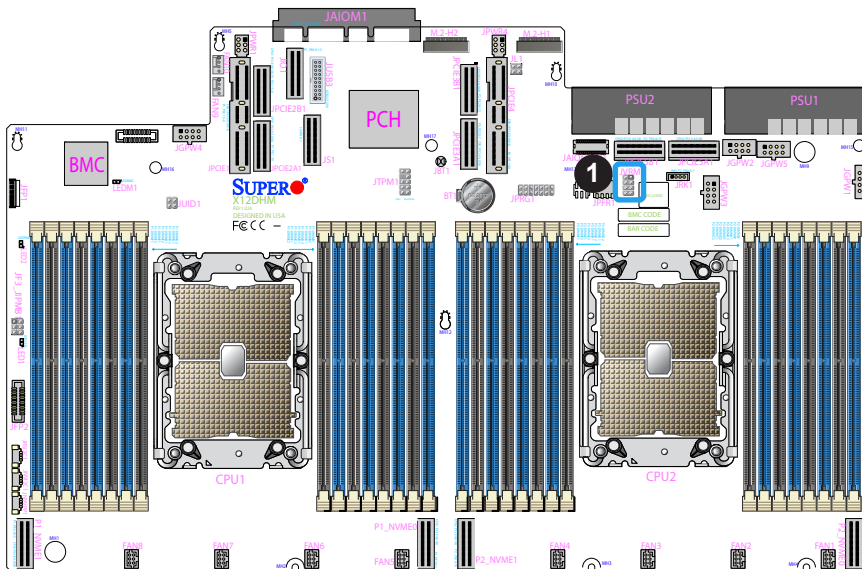

2.9 LED Indicators

BMC Heartbeat LED

A BMC Heartbeat LED is located at LEDM1 on the motherboard. When LEDM1 is blinking, the BMC is functioning normally. Please refer to the table below for more information.

BMC Heartbeat LED Indicator	
LED Color	Definition
Green: Blinking	BMC Normal

1. BMC Heartbeat LED (LEDM1)

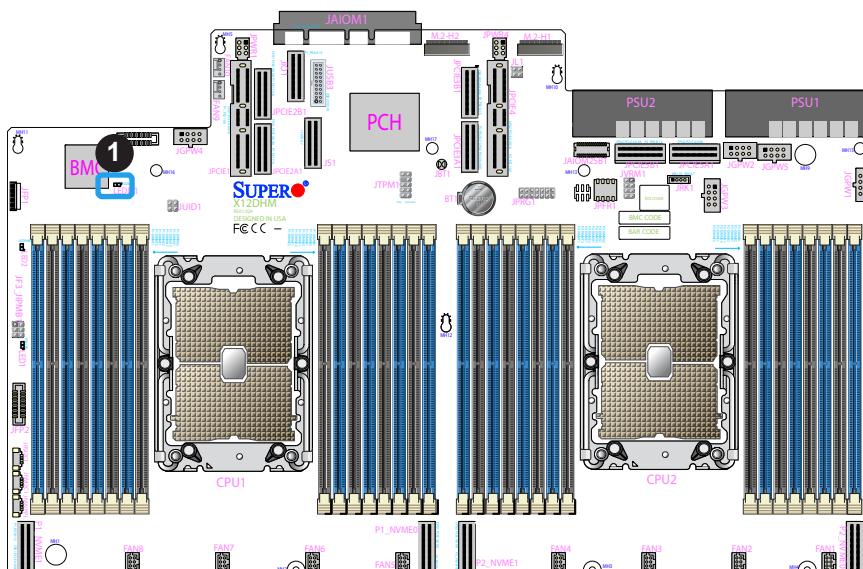

Unit Identifier (UID) Button and UID LED Indicator

An onboard unit identifier LED (LED1) are located on the motherboard. The front UID LED is located on pins 3 of the front panel control header (JFP1). When you press the front UID button, both front and onboard UID LEDs will be turned on. Press the UID switch again to turn off the LED indicators. The UID indicators provide easy identification of a system that may be in need of service.

Note: UID can also be triggered via BMC on the motherboard. For more information on BMC, please refer to the BMC User's Guide posted on our website at <http://www.supermicro.com>.

UID LED	
LED Color	Definition
Blue: On	Unit Identified

1. UID LED (LED1)
2. UID LED_N (JFP1)

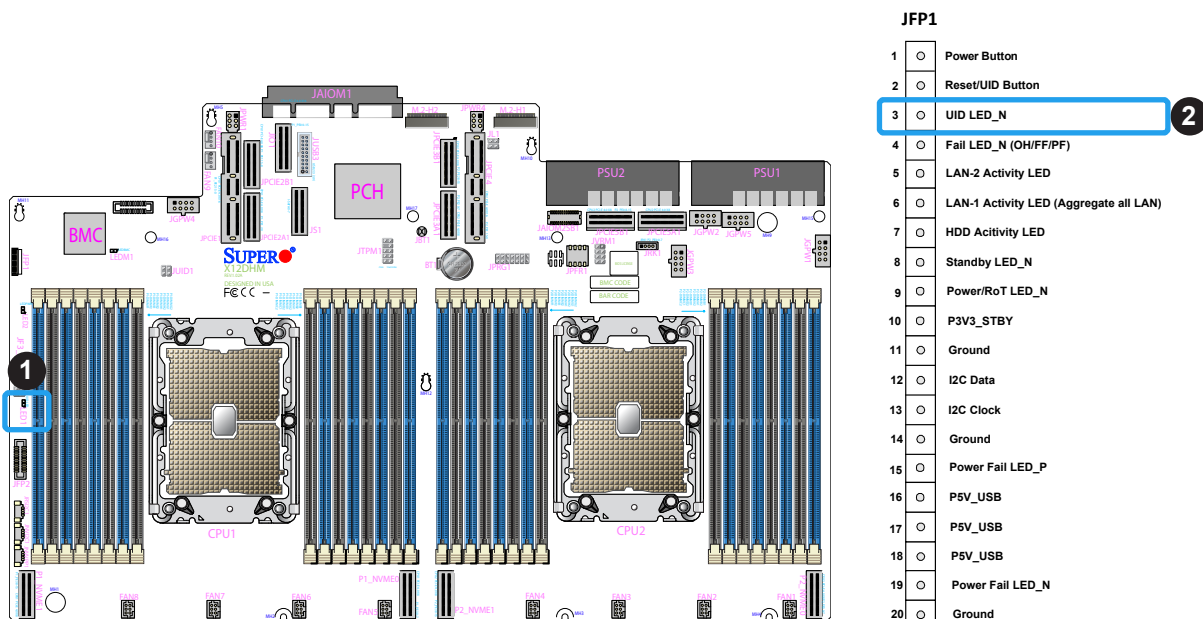

Onboard Power LED

The onboard Power LED is located at LED2 on the motherboard. When this LED is on, the system power is on. Be sure to turn off the system power and unplug the power cord before removing or installing components. Refer to the table below for more information.

Onboard Power LED Indicator	
LED Color	Definition
Off	System Power Off (power cable not connected)
Green	System Power On

1. Power LED (LED2)

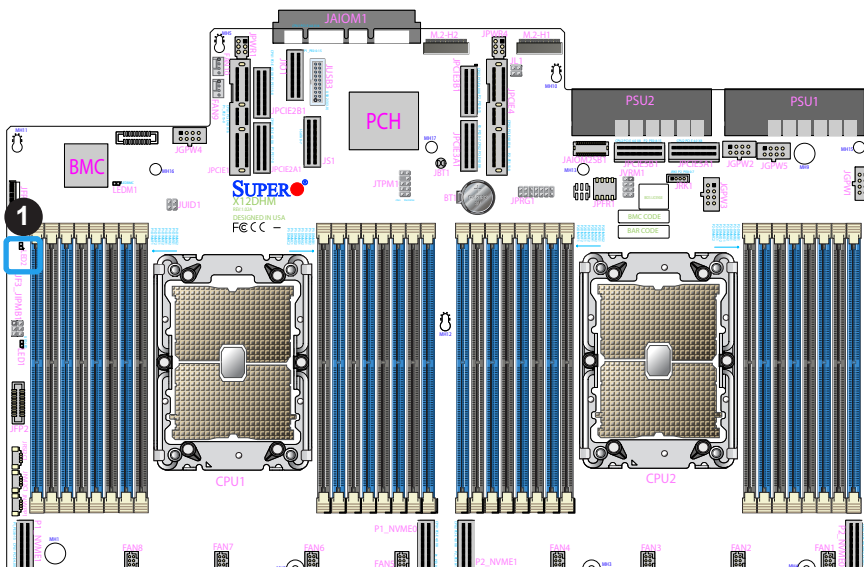

Chapter 3

Troubleshooting

3.1 Troubleshooting Procedures

Use the following procedures to troubleshoot your system. If you have followed all of the procedures below and still need assistance, refer to the 'Technical Support Procedures' and/or 'Returning Merchandise for Service' section(s) in this chapter. Always disconnect the AC power cord before adding, changing or installing any non hot-swap hardware components.

Before Power On

1. Make sure that there are no short circuits between the motherboard and chassis.
2. Disconnect all ribbon/wire cables from the motherboard, including those for the keyboard and mouse.
3. Remove all add-on cards.
4. Install the CPU (making sure it is fully seated) and connect the front panel connectors to the motherboard.

No Power

1. Make sure that there are no short circuits between the motherboard and the chassis.
2. Make sure that the ATX power connectors are properly connected.
3. Check that the 115V/230V switch, if available, on the power supply is properly set.
4. Turn the power switch on and off to test the system, if applicable.
5. The battery on your motherboard may be old. Check to verify that it still supplies ~3VDC. If it does not, replace it with a new one.

No Video

1. If the power is on, but you have no video, remove all add-on cards and cables.
2. Remove all memory modules and turn on the system (if the alarm is on, check the specs of memory modules, reset the memory or try a different one).

System Boot Failure

If the system does not display POST (Power-On-Self-Test) or does not respond after the power is turned on, check the following:

1. Remove all components from the motherboard, especially the DIMM modules. Power on the system and check if the power-on LED (LE2) and the BMC Heartbeat LED (LEDM1) are on, and system fans are spinning.
2. Turn on the system with only one DIMM module installed. If the system boots, check for bad DIMM modules or slots by following the Memory Errors Troubleshooting procedure in this chapter.

Memory Errors

When a no-memory beep code is issued by the system, check the following:

1. Make sure that the memory modules are compatible with the system and are properly installed. See Chapter 2 for installation instructions. (For memory compatibility, refer to the "Tested Memory List" link on the motherboard's product page to see a list of supported memory.)
2. Check if different speeds of DIMMs have been installed. It is strongly recommended that you use the same RAM type and speed for all DIMMs in the system.
3. Make sure that you are using the correct type of ECC DDR4 modules recommended by the manufacturer.
4. Check for bad DIMM modules or slots by swapping a single module among all memory slots and check the results.

Losing the System's Setup Configuration

1. Make sure that you are using a high-quality power supply. A poor-quality power supply may cause the system to lose the CMOS setup information. Refer to Chapter 2 for details on recommended power supplies.
2. The battery on your motherboard may be old. Check to verify that it still supplies ~3VDC. If it does not, replace it with a new one.

When the System Becomes Unstable

A. If the system becomes unstable during or after OS installation, check the following:

1. CPU/BIOS support: Make sure that your CPU is supported and that you have the latest BIOS installed in your system.
2. Memory support: Make sure that the memory modules are supported by testing the modules using memtest86 or a similar utility.



Note: Click on the "Tested Memory List" link on the motherboard's product page to see a list of supported memory.

3. HDD support: Make sure that all hard disk drives (HDDs) work properly. Replace the bad HDDs with good ones.
4. System cooling: Check the system cooling to make sure that all heatsink fans and CPU/system fans, etc., work properly. Check the hardware monitoring settings in the BMC to make sure that the CPU and system temperatures are within the normal range. Also check the front panel Overheat LED and make sure that it is not on.
5. Adequate power supply: Make sure that the power supply provides adequate power to the system. Make sure that all power connectors are connected. Please refer to our website for more information on the minimum power requirements.
6. Proper software support: Make sure that the correct drivers are used.

B. If the system becomes unstable before or during OS installation, check the following:

1. Source of installation: Make sure that the devices used for installation are working properly, including boot devices such as CD/DVD.
2. Cable connection: Check to make sure that all cables are connected and working properly.
3. Using the minimum configuration for troubleshooting: Remove all unnecessary components (starting with add-on cards first), and use the minimum configuration (but with the CPU and a memory module installed) to identify the trouble areas. Refer to the steps listed in Section A above for proper troubleshooting procedures.

4. Identifying bad components by isolating them: If necessary, remove a component in question from the chassis, and test it in isolation to make sure that it works properly. Replace a bad component with a good one.
5. Check and change one component at a time instead of changing several items at the same time. This will help isolate and identify the problem.
6. To find out if a component is good, swap this component with a new one to see if the system will work properly. If so, then the old component is bad. You can also install the component in question in another system. If the new system works, the component is good and the old system has problems.

3.2 Technical Support Procedures

Before contacting Technical Support, please take the following steps. Also, please note that as a motherboard manufacturer, Supermicro also sells motherboards through its channels, so it is best to first check with your distributor or reseller for troubleshooting services. They should know of any possible problems with the specific system configuration that was sold to you.

1. Please go through the Troubleshooting Procedures and Frequently Asked Questions (FAQ) sections in this chapter or see the FAQs on our website (<http://www.supermicro.com/FAQ/index.php>) before contacting Technical Support.
2. BIOS upgrades can be downloaded from our website (http://www.supermicro.com/ResourceApps/BIOS_BMC_Intel.html).
3. If you still cannot resolve the problem, include the following information when contacting Supermicro for technical support:
 - Motherboard model and PCB revision number
 - BIOS release date/version (This can be seen on the initial display when your system first boots up.)
 - System configuration
4. An example of a Technical Support form is on our website at <http://www.supermicro.com/RmaForm/>.
5. Distributors: For immediate assistance, please have your account number ready when placing a call to our Technical Support department. We can be reached by email at support@supermicro.com.

3.3 Frequently Asked Questions

Question: What type of memory does my motherboard support?

Answer: This motherboard supports up to 8TB of 3DS LRDIMM/LRDIMM/3DS RDIMM/RDIMM DDR4 (288-pin) ECC memory with speeds of 3200/2933/2666 MHz in 32 slots and up to 8TB of Intel Optane PMem 200 Series with speeds of up to 3200 MHz. (See the notes below). To enhance memory performance, do not mix memory modules of different speeds and sizes. Please follow all memory installation instructions given on Section 2-4 in Chapter 2.

 **Note :** Intel® Optane™ Persistent Memory (PMem) 200 Series is supported by the 3rd Gen Intel Xeon Scalable (83xx/63xx/53xx/4314 Series) Processors.

Question: How do I update my BIOS?

Answer: It is recommended that you do not upgrade your BIOS if you are not experiencing any problems with your system. Updated BIOS files are located on our website at http://www.supermicro.com/ResourceApps/BIOS_BMC_Intel.html. Please check our BIOS warning message and the information on how to update your BIOS on our website. Select your motherboard model and download the BIOS file to your computer. Also, check the current BIOS revision to make sure that it is newer than your BIOS before downloading.

 **Note:** The SPI BIOS chip used on this motherboard cannot be removed. Send your motherboard back to our RMA Department at Supermicro for repair. For BIOS Recovery instructions, please refer to the AMI BIOS Recovery Instructions posted at <http://www.supermicro.com/support/manuals/>.

Note 2: For BIOS Update and Recovery instructions, please refer to the Firmware update and Recovery Instructions for Supermicro's X12 Motherboards User's Guide posted at <http://www.supermicro.com/support/manuals/>.

3.4 Battery Removal and Installation

Battery Removal

To remove the onboard battery, follow the steps below:

1. Power off your system and unplug your power cable.
2. Locate the onboard battery as shown below.
3. Using a tool such as a pen or a small screwdriver, push the battery lock outwards to unlock it. Once unlocked, the battery will pop out from the holder.
4. Remove the battery.

Proper Battery Disposal

Warning: Please handle used batteries carefully. Do not damage the battery in any way; a damaged battery may release hazardous materials into the environment. Do not discard a used battery in the garbage or a public landfill. Please comply with the regulations set up by your local hazardous waste management agency to dispose of your used battery properly.

Battery Installation

To install an onboard battery, follow the steps below:

1. Power off your system and unplug your power cable.
2. Locate the onboard battery as shown below
3. Identify the battery's polarity. The positive (+) side should be facing up.
4. Insert the battery into the battery holder and push it down until you hear a click to ensure that the battery is securely locked.

Warning: When replacing a battery, be sure to only replace it with the same type.

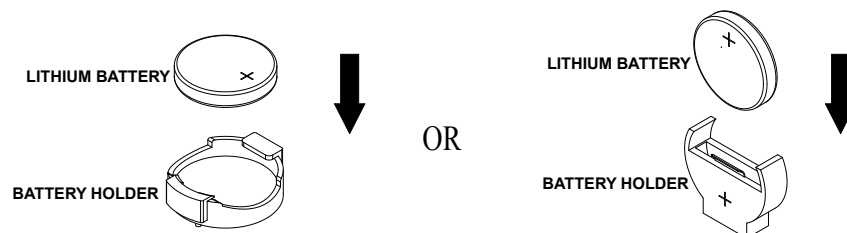

3.5 Returning Merchandise for Service

A receipt or copy of your invoice marked with the date of purchase is required before any warranty service will be rendered. You can obtain service by calling your vendor for a Returned Merchandise Authorization (RMA) number. When returning the motherboard to the manufacturer, the RMA number should be prominently displayed on the outside of the shipping carton, and the shipping package is mailed prepaid or hand-carried. Shipping and handling charges will be applied for all orders that must be mailed when service is complete. For faster service, you can also request a RMA authorization online (<http://www.supermicro.com/RmaForm/>).

This warranty only covers normal consumer use and does not cover damages incurred in shipping or from failure due to the alternation, misuse, abuse or improper maintenance of products.

During the warranty period, contact your distributor first for any product problems.

Chapter 4

UEFI BIOS

4.1 Introduction

This chapter describes the AMIBIOS™ Setup utility for the motherboard. The BIOS is stored on a chip and can be easily upgraded using a flash program.



Note: Due to periodic changes to the BIOS, some settings may have been added or deleted and might not yet be recorded in this manual. Please refer to the Manual Download area of our website for any changes to the BIOS that may not be reflected in this manual.

Starting the Setup Utility

To enter the BIOS Setup Utility, hit the <Delete> key while the system is booting-up. (In most cases, the <Delete> key is used to invoke the BIOS setup screen. There are a few cases when other keys are used, such as <F1>, <F2>, etc.) Each main BIOS menu option is described in this manual.

The Main BIOS screen has two main frames. The left frame displays all the options that can be configured. “Grayed-out” options cannot be configured. The right frame displays the key legend. Above the key legend is an area reserved for a text message. When an option is selected in the left frame, it is highlighted in white. Often a text message will accompany it. (Note that the BIOS has default text messages built in. We retain the option to include, omit, or change any of these text messages.) Settings printed in **Bold** are the default values.

A " ►" indicates a submenu. Highlighting such an item and pressing the <Enter> key will open the list of settings within that submenu.

The BIOS setup utility uses a key-based navigation system called hot keys. Most of these hot keys (<F1>, <F2>, <F3>, <Enter>, <ESC>, <Arrow> keys, etc.) can be used at any time during the setup navigation process.

4.2 Main Setup

When you first enter the AMI BIOS setup utility, you will enter the Main setup screen. You can always return to the Main setup screen by selecting the Main tab on the top of the screen. The Main BIOS setup screen is shown below and the following items will be displayed:

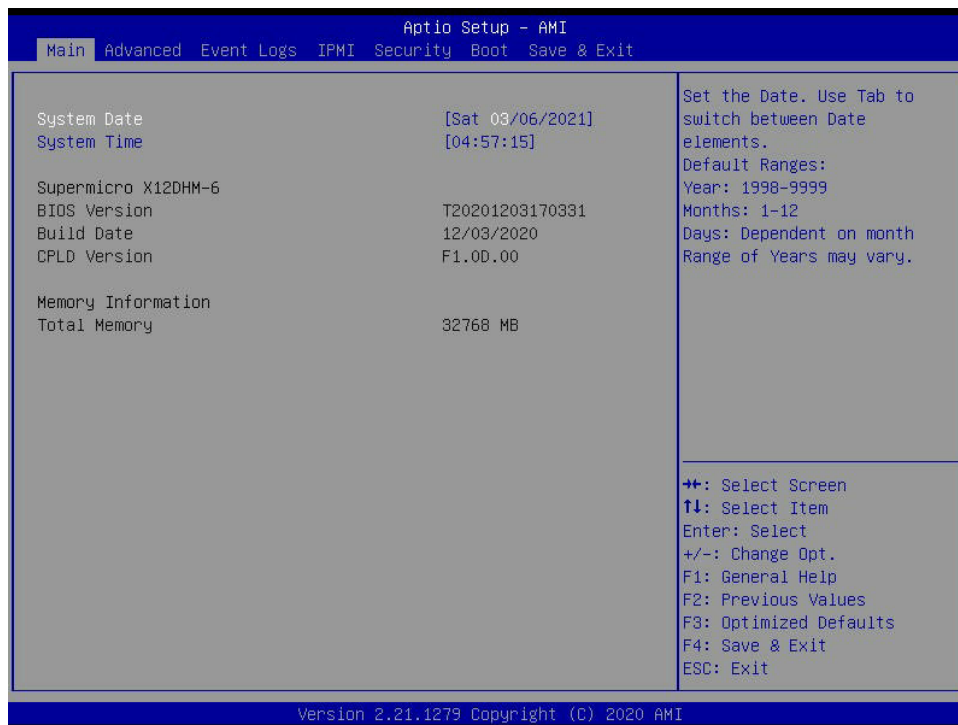

System Date/System Time

Use this option to change the system date and time. Highlight *System Date* or *System Time* using the arrow keys. Enter new values using the keyboard. Press the <Tab> key or the arrow keys to move between fields. The date must be entered in MM/DD/YYYY format. The time is entered in HH:MM:SS format.

 **Note:** The time is in the 24-hour format. For example, 5:30 P.M. appears as 17:30:00. The date's default value is the BIOS build date after RTC reset.

Supermicro X12DHM-6

BIOS Version

This item displays the version of the BIOS ROM used in the system.

Build Date

This item displays the date when the version of the BIOS ROM used in the system was built.

CPLD Version

This item displays the Complex Programmable Logic Device version.

Memory Information**Total Memory**

This item displays the total size of memory available in the system.

4.3 Advanced Setup Configurations

Use the arrow keys to select the Advanced menu and press <Enter> to access the submenu items:

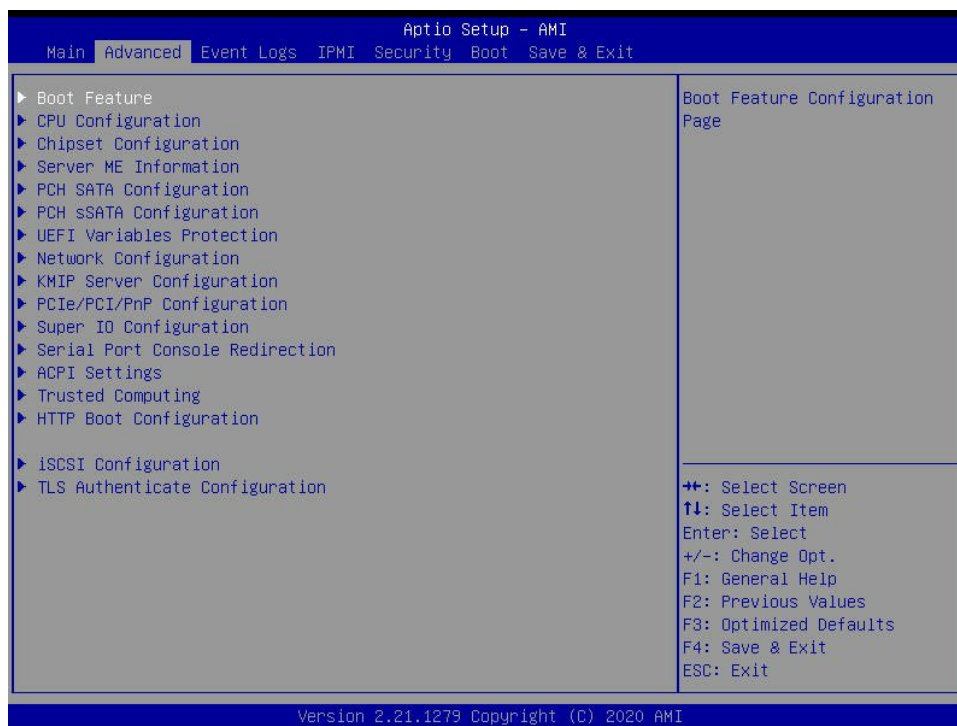

Warning: Take caution when changing the Advanced settings. An incorrect value, a very high DRAM frequency, or an incorrect DRAM timing setting may make the system unstable. When this occurs, revert to default manufacturer settings.

► Boot Feature

Quiet Boot

Use this feature to select the screen display between the POST messages and the OEM logo upon bootup. Select Disabled to display the POST messages. Select Enabled to display the OEM logo instead of the normal POST messages. The options are Disabled and **Enabled**.



Note: BIOS POST (Power-on Self Test) messages are always displayed regardless of the setting for this feature.

Option ROM Messages

Use this feature to set the display mode for the Option ROM. Select Keep Current to display the current AddOn ROM setting. Select Force BIOS to use the Option ROM display set by the system BIOS. The options are **Force BIOS** and Keep Current.

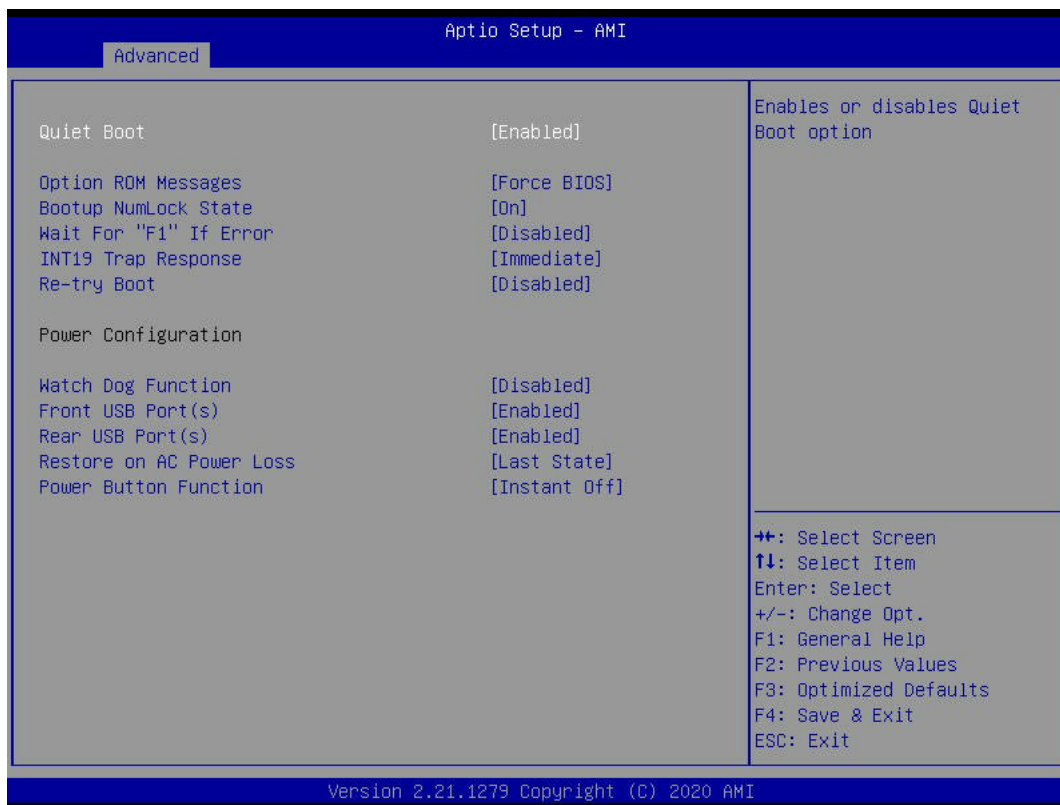

Bootup NumLock State

Use this feature to set the Power-on state for the <Numlock> key. The options are **On** and Off.

Wait For "F1" If Error

Use this feature to force the system to wait until the "F1" key is pressed if an error occurs. The options are **Disabled** and Enabled.

INT19 Trap Capture

Interrupt 19 is the software interrupt that handles the boot disk function. When this feature is set to Immediate, the ROM BIOS of the host adapters will "capture" Interrupt 19 at bootup immediately and allow the drives that are attached to these host adapters to function as bootable disks. If this feature is set to Postponed, the ROM BIOS of the host adapters will not capture Interrupt 19 immediately and allow the drives attached to these adapters to function as bootable devices at bootup. The options are **Immediate** and Postponed.

Re-try Boot

When EFI (Extensible Firmware Interface) Boot is selected, the system BIOS will automatically reboot the system from an EFI boot device after an initial boot failure. Select Legacy Boot to allow the BIOS to automatically reboot the system from a Legacy boot device after an initial boot failure. The options are **Disabled**, Legacy Boot, and EFI Boot.

Power Configuration

Watch Dog Function

Select Enabled to allow the Watch Dog timer to reboot the system when it is inactive for more than 5 minutes. The options are Enabled and **Disabled**.

If this feature is set to Enabled, the following feature will display:

Watch Dog Action (Available when "Watch Dog Function" is set to Enabled.)

This feature allows the user to determine how the watch dog function can be triggered. The options are NMI and **Reset**.

Front USB Port(s)

Select Enabled to allow the specific type of USB devices to be used in the front USB ports. Select Enabled (Dynamic) to allow or disallow this particular type of USB devices to be used in the front USB ports without rebooting the system. The options are **Enabled**, Disabled, and Enabled (Dynamic).

Rear USB Port(s)

Select Enabled to allow the specific type of USB devices to be used in the rear USB ports. Select Enabled (Dynamic) to allow or disallow this particular type of USB devices to be used in the rear USB ports without rebooting the system. The options are **Enabled**, Disabled, and Enabled (Dynamic).

Restore on AC Power Loss

Use this feature to set the power state after a power outage. Select Stay Off for the system power to remain off after a power loss. Select Power On for the system power to be turned on after a power loss. Select Last State to allow the system to resume its last power state before a power loss. The options are Stay Off, Power On, and **Last State**.

Power Button Function

This feature controls how the system shuts down when the power button is pressed. Select 4 Seconds Override for the user to power off the system after pressing and holding the power button for four seconds or longer. Select Instant Off to instantly power off the system as soon as the user presses the power button. The options are **Instant Off** and 4 Seconds Override.

► CPU Configuration

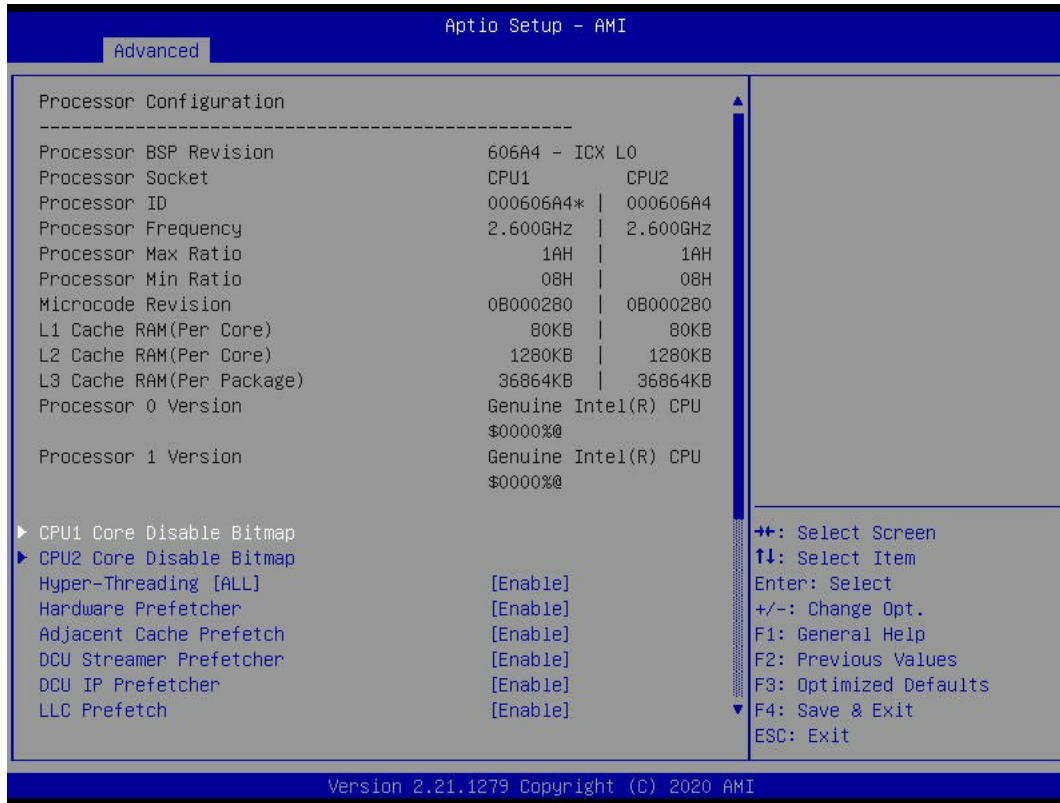

The following CPU information will display:

- Processor BSP Revision
- Processor Socket
- Processor ID
- Processor Frequency
- Processor Max Ratio
- Processor Min Ratio
- Microcode Revision
- L1 Cache RAM
- L2 Cache RAM
- L3 Cache RAM
- Processor 0 Version
- Processor 1 Version

►CPU1 Core Disable Bitmap/CPU2 Core Disable Bitmap

The following features will display:

Available Bitmap: The available Bitmap will displayed.

Core Disable Bitmap (Hex)

Enter 0 to enable all CPU cores. Enter FFFFFFFFFF to disable all CPU cores. Please note that at least one core per CPU must be enabled. Disabling all cores is not allowed. The default option is **0**.

Hyper-Threading (ALL) (Available when supported by the CPU)

Select Enable to support Intel Hyper-threading Technology to enhance CPU performance. The options are Disable and **Enable**.

Hardware Prefetcher

If this feature is set to Enable, the hardware prefetcher will prefetch data from the main system memory to Level 2 cache to help expedite data transaction to enhance memory performance. The options are Disable and **Enable**.

Adjacent Cache Prefetch

Select Enable for the CPU to prefetch both cache lines for 128 bytes as comprised. Select Disable for the CPU to prefetch both cache lines for 64 bytes. The options are Disable and **Enable**. (**Note:** Refer to Intel's website for detailed information.)

DCU Streamer Prefetcher

If this feature is set to Enable, the DCU (Data Cache Unit) streamer prefetcher will prefetch data streams from the cache memory to the DCU (Data Cache Unit) to speed up data accessing and processing to enhance CPU performance. The options are Disable and **Enable**.

DCU IP Prefetcher

This feature allows the system to use the sequential load history, which is based on the instruction pointer of previous loads, to determine whether the system will prefetch additional lines. The options are **Enable** and Disable.

LLC Prefetch

If this feature is set to Enable, LLC (hardware cache) prefetching on all threads will be supported. The options are **Enable** and Disable.

Extended APIC (Extended Advanced Programmable Interrupt Controller)

Based on the Intel Hyper-Threading technology, each logical processor (thread) is assigned 256 APIC IDs (APIDs) in 8-bit bandwidth. When this feature is set to Enable, the APIC ID will be expanded from 8 bits to 16 bits to provide 512 APIDs to each thread to enhance CPU performance. The options are **Disable** and Enable.

DCU IP Prefetcher (Available when supported by the CPU)

Select Enable for DCU (Data Cache Unit) IP Prefetcher support, which will prefetch IP addresses to improve network connectivity and system performance. The options are **Enable** and Disable.

LLC Prefetch

If set to Enable, the hardware prefetcher will prefetch streams of data and instructions from the main memory to the L3 cache to improve CPU performance. The options are **Disable** and Enable.

Extended APIC

Select Enable to activate APIC (Advanced Programmable Interrupt Controller) support. The options are **Disable** and Enable.

VMX

Select Enable to enable the Intel Vanderpool Technology for Virtualization platform support, which will allow multiple operating systems to run simultaneously on the same computer to maximize system resources for performance enhancement. The options are **Enable** and Disable.

Enable SMX

Select Enable to support Safer Mode Extensions (SMX) which provides a programming interface for system software to establish a controlled environment to support the trusted platform configured by the end user and to verify a virtual machine monitor before it is allowed to run. The options are **Disable** and Enable.

PPIN Control

Select Unlock/Enable to use the Protected-Processor Inventory Number (PPIN) in the system. The options are **Unlock/Enable** and Lock/Disable.

AES-NI

Select Enable to use the Intel Advanced Encryption Standard (AES) New Instructions (NI) to ensure data security. The options are **Enable** and Disable.

TME, TME-MT, TDX

Total Memory Encryption (TME)

Select Enabled for total memory encryption support to enhance memory data security. The options are **Disabled** and Enabled.

If this feature is set to Enabled, the followings item will display:

Total Memory Encryption Multi-Tenant (TME-MT) (Available when "Total Memory Encryption" is set to Enabled & "Limit CPU PA to 46 Bits" below is set to Disable)

Select Enabled for Total Memory Encryption Multi-Tenant support to maximize memory data security. The options are **Disabled** and Enabled.

If this feature is set to Enabled, the followings item will display:

Max TME-MT Keys (Available when Total Memory Encryption is set to Enabled)

This feature displays the value of maximum Total Memory Encryption Multi-Tenant (TME-MT) keys.

Software Guard Extension (SGX)



Note: For SGX to work properly, please use the CPUs that support this feature and be sure to install one CPU per channel.

SGX Factory Reset (Available when TME-MT is set to Enabled and the SGX feature is supported by the CPU used in the system)

Select Enabled to reset the factory default setting for SGX (Software Guard Extension). The options are **Disabled** and Enabled.

SW (Software) Guard Extensions (SGX) (Available when TME-MT is set to Enabled and the SGX feature is supported by the CPU used in the system)

Select Enabled to support Software Guard Extensions (SGX) for memory data security enhancement. The options are **Disabled** and Enabled.

SGX Package Info In-Band Access (Available when TME-MT is set to Enabled and the SGX feature is supported by the CPU used in the system)

If this feature is set to Enabled, Software Guard Extensions (SGX) package information will become available for in-band access. The options are **Disabled** and Enabled.

Limit CPU PA to 46 bits

Select Enable to limit CPU physical address to 46 bits to support the older Hyper-v CPU platform. The options are Enable and **Disable**.

► Advanced Power Management Configuration

Power Technology

Select Energy Efficiency to support power-saving mode. Select Custom to customize system power settings. Select Disable to disable power-saving settings. The options are Disable, Energy Efficient, and **Custom**.

****If the feature above is set to Custom, the following features will become available for configuration:***

Power Performance Tuning

This feature allows the user to select whether the BIOS or Operating System chooses energy performance bias tuning. The options are **OS Controls EPB** or BIOS Controls EPB.

****If the item above is set to BIOS Controls EPB, the following item will be displayed:***

ENERGY_PERF_BIAS_CFG Mode (ENERGY PERFORMANCE BIAS CONFIGURATION Mode) (Available when "Power Performance Tuning" is set to BIOS Controls EPB)

Use this feature to configure the proper operation setting for your machine by achieving the desired system performance level and energy saving (efficiency) level at the same time. Select Performance to enhance system performance; however, this may consume more power as energy is needed to fuel the processors for operation. The options are Maximum Performance, Performance, **Balanced Performance**, Balanced Power, and Power.

► CPU P State Control (Available when "Power Technology" is set to Custom)

SpeedStep (P-States)

EIST (Enhanced Intel SpeedStep Technology) allows the system to automatically adjust processor voltage and core frequency in an effort to reduce power consumption and heat dissipation. Please refer to Intel's website for detailed information. The options are Disable and **Enable**.

Dynamic SST-PP (Speed Select Technology-Performance Profile)

If this feature is set to Enable, the user will be able to configure Intel SST-PP features, including Base, Configuration 3, and Configuration 4 settings under various processor working conditions. The options are **Disable** and Enable.

Intel SST-PP (Speed Select Technology-Performance Profile)

This feature allows the user to choose from two additional Base-Frequency conditions maximum for CPU P State Control. The options are **Base**, Config (Configuration) 3, and Config (Configuration) 4.

Activate SST-BF (Speed Select Technology-Base Frequency)

Select Enable for Intel Speed Select Technology-Base Frequency support. The options are **Disable** and **Enable**.

Configure SST-BF (Speed Select Technology-Base Frequency)

When this feature is set to Enable, the system BIOS will configure SST-BF High Priority Core settings so that system software does not have to configure these settings. The options are **Enable** and **Disable**.

EIST (Enhanced Intel SpeedStep Technology) PSD Function (Available when "SpeedStep" is set to Enable)

This feature reduces the latency that occurs when one P-state changes to another, thus allowing the transitions of P-state changing to occur more frequently. This will allow for more demand-based P-state changing or switching is based on real-time energy needs of applications so that the power-to-performance balance can be optimized for energy efficiency. The options are **HW_ALL** and **SW_ALL**.

Turbo Mode (Available when "SpeedStep" is set to Enable)

Select enable to allow the CPU to operate at the manufacturer-defined turbo speed by increasing CPU clock frequency. This feature is available when it is supported by the processors used in the system. The options are **Disable** and **Enable**.

CPU Flex Ratio Override (Available when supported by the CPU installed on the motherboard)

Select enable to override the CPU Flex-Ratio setting, which is the minimum multiplier that allows the computer to clock. The options are **Enable** and **Disable**.

CPU Core Flex Ratio (Available when supported by the CPU installed on the motherboard and when "CPU Flex Ratio Override" is set to Enable)

Use this feature to configure the Core Ratio Multiplier settings for non-Turbo mode processors. The default setting is **23**.

► Hardware PM (Power Management) State Control (Available when "Power Technology" is set to Custom)

Hardware P-States

If this feature is set to **Disable**, system hardware will choose a P-state setting for the system based on an OS request. If this feature is set to **Native Mode**, hardware will choose a P-state setting based on the OS guidance. If this feature is set to **Native Mode with No Legacy Support**, system hardware will choose a P-state setting independently without OS guidance. The options are **Disable**, **Native Mode**, **Out of Band Mode**, and **Native Mode with No Legacy Support**.

► Frequency Prioritization

RAPL Prioritization

Select Enable to prioritize RAPL (Running Average Power Limit) which sets the power consumption limit for a processor to save energy. The options are Enable and Disable.

► CPU C State Control

Enable Monitor Mwait

Select Enable to support Monitor and Mwait, which are two instructions in Streaming SIMD Extension 3 (SSE3), to improve synchronization between multiple threads for CPU performance enhancement. The options are **Enable**, and Disable.

CPU C6 Report (Available when "Autonomous Core C-State" is set to Disable)

Select Enable to allow the BIOS to report the CPU C6 state (ACPI C3) to the operating system. During the CPU C6 state, power to all caches is turned off. The options are **Auto**, Enable, and Disable.

Enhanced Halt State (C1E) (Available when "Autonomous Core C-State" is set to Disable)

Select Enable to enable "Enhanced Halt State" support, which will significantly reduce the CPU's power consumption by minimizing CPU's clock cycles and reduce voltage during a "Halt State". The options are Disable and **Enable**.

► Package C State Control

Package C State

Use this feature to optimize and reduce CPU package power consumption in idle mode. Please note that the changes you've made in this setting will affect all CPU cores or the circuits of the entire system. The options are C0/C1 state, C2 state, C6 (non-Retention) state and **Auto**.

► CPU T State Control (Available when "Power Technology" is set to Custom)

Software Controlled T-States

If this feature is set to Enable, CPU throttling will be controlled by the OS, which will reduce the speed of CPU. The options are Enable and **Disable**.

► Chipset Configuration

Warning: Setting the wrong values in the following features may cause the system to malfunction.



► North Bridge

This feature allows the user to configure Intel North Bridge parameters.

► Uncore Configuration

This section allows the user to configure the following Uncore settings:

- Number of CPU
- Number of IIO
- Current UPI Link Speed
- Current UPI Link Frequency
- Global MMIO Low Base/Limit
- Global MMIO High Base/Limit
- PCIe Configuration Base/Size

Degrade Precedence

Use this feature to select the degrading precedence option for Ultra Path Interconnect (UPI) connections. Select Topology Precedent to degrade UPI features if the system options are in conflict. Select Feature Precedent to degrade UPI topology if system options are in conflict. The options are **Topology Precedence** and Feature Precedence.

Link L0p Enable

Select Enable for the system BIOS to enable Link L0p support which will allow the CPU to reduce the UPI links from full width to half width in the event when the CPU's workload is low in an attempt to save power. This feature is available for the system that uses Intel processors with UPI technology support. The options are **Disable**, Enable, and Auto.

 **Note:** You can change the performance settings for non-standard applications by using this parameter. It is recommended that the default settings be used for standard applications.

Link L1 Enable

Select Enable for the BIOS to activate Link L1 support which will power down the UPI links to save power when the system is idle. This feature is available for the system that uses Intel processors with UPI technology support. The options are **Disable**, Enable, and Auto.

 **Note:** Link L1 is an excellent feature for an idle system. L1 is used during Package C-States when its latency is hidden by other components during a wakeup.

XPT Remote Prefetch

Select Enable to support XPT (Extended Prediction Table) Remote Prefetch which will allow an LLC request to be duplicated and sent to an appropriate memory controller in a remote machine based on the recent LLC history to reduce latency. The options are Enable, Disable, and **Auto**.

KTI Prefetch

Select Enable for the KTI prefetcher to preload the L1 cache with data deemed relevant which will allow the memory read to start earlier on a DDR bus in an effort to reduce latency. Select Auto for the KTI prefetcher to automatically preload the L1 cache with relevant data whenever is needed. The options are **Auto**, Enable, and Disable.

Local/Remote Threshold

Use this feature to set the threshold for the Interrupt Request (IRQ) signals, which handle hardware interruptions. The options are Disable, **Auto**, Low, Medium, and High.

IO Directory Cache (IODC)

Select Enable for the IODC (I/O Directory Cache) to generate snoops instead of generating memory lockups for remote IIO (InvlToM) and/or WCiLF (Cores). Select Auto for the IODC to generate snoops (instead of memory lockups) for WCiLF (Cores). The options are Disable, **Auto**, Enable for Remote InvltoM Hybrid Push, InvltoM AllocFlow, Enable for Remote InvltoM Hybrid AllocNonAlloc, and Enable for Remote InvltoM and Remote WCiLF.

SNC (Sub NUMA)

Select Enable to use "Sub NUMA Clustering" (SNC), which supports full SNC (2-cluster) interleave and 1-way IMC interleave. Select Auto for 1-cluster or 2-cluster support depending on the status of IMC (Integrated Memory Controller) Interleaving. The options are **Disable** and Enable SNC2 (2-clusters).

XPT Prefetch

Select Enable to support XPT (Extended Prediction Table) Prefetch which will allow an LLC request to be duplicated and sent to an appropriate memory controller based on the recent LLC history to reduce latency. The options are Enable, Disable, and **Auto**.

Snoop Throttle Configuration

Use this feature to set the level of snoop throttle for the PCH, which will determine how much speed to decrease in operation when the system is in the snoop state. The options are Disabled, Low, Medium, High, and **Auto**.

PCIe Remote P2P (Peer-to-Peer) Relaxed Ordering

Select Disable to support PCIe remote peer-to-peer relaxed writing ordering, which will allow hardware to enforce peer-to-peer write ordering. The options are Enable and **Disable**.

Stale AtoS (A to S)

The in-memory directory has three states: I, A, and S states. The I (-invalid) state indicates that the data is clean and does not exist in the cache of any other sockets. The A (-snoop All) state indicates that the data may exist in another socket in an exclusive or modified state. The S state (-Shared) indicates that the data is clean and may be shared in the caches across one or more sockets. When the system is performing "read" on the memory and if the directory line is in A state, we must snoop all other sockets because another socket may have the line in a modified state. If this is the case, a "snoop" will return the modified data. However, it may be the case that a line "reads" in an A state, and all the snoops come back with a "miss". This can happen if another socket reads the line earlier and then has silently dropped it from its cache without modifying it. If "Stale AtoS" is enabled, a line will transition to the S state when the line in the A state returns only snoop misses. That way, subsequent reads to the line will encounter it in the S state and will not have to snoop, saving the latency and snoop bandwidth. Stale "AtoS" may be beneficial in a workload where there are many cross-socket reads. The options are Disable, Enable, and **Auto**.

LLC Dead Line Alloc

Select Enable to opportunistically fill the deadlines in the LLC. The options are **Enable**, Disable, and Auto.

► Memory Configuration

STEP DRAM Test

Use this feature to enable STEP (Samsung Test BIOS & Enhanced PPR) function of the system. The options are Enable and **Disable**.

Operation Mode (Available when STEP DRAM Test is set to Enable)

Use this feature to select the STEP operation mode. The options are Test Only and **Test and Repair**.

Enforce POR (Plan of Record)

Select POR to enforce POR restrictions for DDR4 memory frequency and voltage programming. The options are **POR** and Disable.

PPR Type

Post Package Repair (PPR) is a new feature available for the DDR4 Technology. PPR provides additional spare capacity within a DDR4 DRAM module that is used to replace faulty cell areas detected during system boot. PPR offers two types of memory repairs. Soft Post Package Repair (sPPR) provides a quick, temporary fix on a raw element in a bank group of a DDR4 DRAM device, while hard Post Package Repair (hPPR) will take a longer time to provide a permanent repair on a raw element. The options are Soft PPR, **Hard PPR**, and PPR Disabled.

Memory Frequency

Use this feature to set the maximum memory frequency for onboard memory modules. The options are **Auto**, 2133, 2200, 2400, 2600, 2666, 2800, 2933, 3000, and 3200. (**Note:** Maximum memory frequency is dependent on the CPU SKU.)

Data Scrambling for DDR4

Select Enable to enable data scrambling for DDR4 modules to enhance memory data security. Select Auto to use the Memory Reference Code (MRC) defaulting setting for DDR4 data scrambling. The options are **Enable** and Disable.

2X Refresh Enable

Select Enable for memory 2X refresh support to enhance memory performance. The options are Disable, Enable, and **Auto**.

▶ Memory Topology

This item displays the information of onboard memory modules as detected by the BIOS.

▶ Memory RAS (Reliability_Availability_Serviceability) Configuration

Enable Pcode WA (Workaround) for SAI (Security Attribute of the Initiator) PG (Policy Group)

Pcode, a register transfer language designed for reverse engineering, translates individual processor instructions into a sequence of Pcode operations in order to facilitate the construction of data-flow graphs and disassembling of processor instructions for machine application. Select Enabled to allow Pcode to work around the SAI group policy to achieve a solution with a next-step instruction. The options are **Disabled** and Enabled.

Mirror Mode (Unavailable when "UEFI ARM Mirror" below is set to Enabled and "ADDDC Sparing" below is set to Disabled)

Use this feature to configure the mirror mode settings for all 1LM/2LM memory modules installed in the system which will create a duplicate copy of data stored in the memory to increase memory security, but it will reduce the memory capacity into half. The options are **Disabled** and Full Mirror Mode.

UEFI ARM Mirror (Only available when "Mirror Mode" is set to Disabled and "ADDDC Sparing" is set to Disabled)

Select Enabled to mimic behavior of UEFI-based ARM (Address Range Mirror) with setup options to increase memory security, but it will reduce the memory capacity into half. The options are **Disabled** and Enabled.

Correctable Error Threshold

This feature allows the user to enter the threshold value for correctable memory errors. The default setting is **512**.

Partial Cache Line Sparing (PCLS)

Select Enabled to support partial cache line sparing, which will allow partial of data contained in a cache line to be copied in the cache memory for safe-keeping/data security. The options are Disabled and **Enabled**.

ADDDC (Adaptive Double Device Data Correction) Sparing

Select Enable for Adaptive Double Device Data Correction (ADDDC) support, which will not only provide memory error checking and correction but will also prevent the system from issuing a performance penalty before a device fails. Please note that virtual lockstep mode will only start to work for ADDDC after a faulty DRAM module is spared. The options are **Enabled** and Disabled.

Patrol Scrub

Patrol Scrubbing is a process that allows the CPU to correct correctable memory errors detected in a memory module and send the corrections to the requestor (the original source). When this feature is set to Enable, the IO hub will read and write back one cache line every 16K cycles if there is no delay caused by internal processing. By using this method, roughly 64 GB of memory behind the IO hub will be scrubbed every day. The options are Enabled, Disabled, and **Enable at End of POST**.

► IIO Configuration

► CPU1 Configuration/CPU2 Configuration

IOU0 (IIO PCIe Port 1)

Use this feature to configure the PCIe Bifurcation setting for a PCIe port specified by the user. The options are x4x4x4x4, x4x4x8, x8x4x4, x8x8, x16, and **Auto**.

IOU1 (IIO PCIe Port 2)

Use this feature to configure the PCIe Bifurcation setting for a PCIe port specified by the user. The options are x4x4x4x4, x4x4x8, x8x4x4, x8x8, x16, and **Auto**.

IOU3 (IIO PCIe Port 4)

Use this feature to configure the PCIe Bifurcation setting for a PCIe port specified by the user. The options are x4x4x4x4, x4x4x8, x8x4x4, x8x8, x16, and **Auto**.

IOU4 (IIO PCIe Port 5)

Use this feature to configure the PCIe Bifurcation setting for a PCIe port specified by the user. The options are x4x4x4x4, x4x4x8, x8x4x4, x8x8, x16, and **Auto**.

► Port 0/DMI (Only available on CPU2 Configuration)

Link Speed

Use this feature to configure the link speed of a PCIe device installed in Port 0 or DMI port. The options are **Auto**, Gen 1 (2.5 GT/s), Gen 2 (5 GT/s), Gen 3 (8 GT/s), and Gen 4 (16 GT/s).

The following information will be displayed:

- PCIe Port Link Status
- PCIe Port Link Max
- PCIe Port Link Speed

DMI Port MPSS (Maximum Payload Size Support) (Available for "CPU1 Configuration" Only)

Use this feature to set the maximum payload size support in the PCIe Device Capabilities Register for the device installed in the DMI port. The options are **Auto**, 128B, and 256B.

▶ IOAT Configuration

Disable TPH

TPH (TLP Processing Hint) is used for data-tagging with a destination ID and a few important attributes. It can send critical data to a particular cache without writing through to memory. Select No for TLP Processing Hint support, which will allow a "TLP request" to provide "hints" to help optimize the processing of each transaction occurred in the target memory space. The options are Yes and **No**.

Prioritize TPH (TLP Processing Hint)

Select Enable to prioritize the TPL requests that will allow the "hints" to be sent to help facilitate and optimize the processing of certain transactions in the system memory. The options are Enable and **Disable**.

Relaxed Ordering

Select Yes to allow certain transactions to be processed and completed before other transactions that have already been enqueued. The options are Yes and **No**.

▶ Intel® VT for Directed I/O (VT-d)

Intel® VT for Directed I/O

Use this feature to enable the Intel Virtualization Technology support for Direct I/O VT-d by reporting the I/O device assignments to the VMM (Virtual Machine Monitor) through the DMAR ACPI tables. This feature offers fully-protected I/O resource sharing across Intel platforms, providing greater reliability, security and availability in networking and data-sharing. The options are **Enable** and Disable.

ACS (Access Control Services) Control (Available when Intel® VT for Directed I/O (VT-d) is set to Yes)

Select Enable to program ACS control to Chipset PCIe Root Port bridges. Select Disable to program ACS control to all PCIe Root Port bridges. The options are **Enable** and Disable.

Interrupt Remapping (Available when "Intel® VT for Directed I/O (VT-d)" is set to Enable)

If this feature is set to Enable, I/O DMA transfer remapping and device-generated interrupts will be supported. The options are **Auto**, Enable, and Disable.

▶ Intel® VMD Technology

This section describes the configuration settings for the Intel VMD Technology.



Note 1. After you've enabled VMD in the BIOS on a PCIe slot, this PCIe slot will be dedicated for VMD use only, and it will no longer support any PCIe device. To re-activate this slot for PCIe use, please disable VMD in the BIOS.

Note 2. PCIe slots and naming can differ depending on the PCIe devices installed on your motherboard.

NVMe Mode Switch

Use this feature to select the NVMe mode. The options are **Auto**, **VMD** and **Manual**.

****If the feature above is set to Manual, the following features will become available for configuration:***

▶ Intel® VMD for Volume Management Device on CPU1

VMD Config for PCH ports

Enable/Disable VMD

Select **Enable** to enable Intel Volume Management Device Technology support for the root port specified by the user. The options are **Enable** and **Disable**.

**If Enable/Disable VMD is set to Enable to a port specified by the user, the following items will display for the port selected.*

PCH Root Port 0/4 (Available for onboard NVMe ports only)

Select **Enable** to enable Intel Volume Management Device Technology support for the root port. The options are **Enable** and **Disable**.

VMD Config for IOU 0

Enable/Disable VMD

Select **Enable** to enable Intel Volume Management Device Technology support for the root port specified by the user. The options are **Enable** and **Disable**.

**If Enable/Disable VMD is set to Enable to a port specified by the user, the following items will display for the port selected.*

VMD Port 1A/1B/1C/1D (Available for onboard NVMe ports only)

Select **Enable** to enable Intel Volume Management Device Technology support for the root port. The options are **Enable** and **Disable**.

Hot Plug Capable

Select **Enable** to enable Hot Plug support for the root ports specified by the user, which will allow the user to change the devices on those root ports without shutting down the system. The options are **Enable** and **Disable**.

VMD Config for IOU 1

Enable/Disable VMD

Select Enable to enable Intel Volume Management Device Technology support for the root port specified by the user. The options are Enable and **Disable**.

**If Enable/Disable VMD is set to Enable to a port specified by the user, the following items will display for the port selected.*

VMD Port 2A/2B/2C/2D (Available for onboard NVMe ports only)

Select Enable to enable Intel Volume Management Device Technology support for the root port. The options are Enable and **Disable**.

Hot Plug Capable

Select Enable to enable Hot Plug support for the root ports specified by the user, which will allow the user to change the devices on those root ports without shutting down the system. The options are **Enable** and Disable.

VMD Config for IOU 3

Enable/Disable VMD

Select Enable to enable Intel Volume Management Device Technology support for the root port specified by the user. The options are Enable and **Disable**.

**If Enable/Disable VMD is set to Enable to a port specified by the user, the following items will display for the port selected.*

VMD Port 4A/4B/4C/4D (Available for onboard NVMe ports only)

Select Enable to enable Intel Volume Management Device Technology support for the root port. The options are Enable and **Disable**.

Hot Plug Capable

Select Enable to enable Hot Plug support for the root ports specified by the user, which will allow the user to change the devices on those root ports without shutting down the system. The options are **Enable** and Disable.

VMD Config for IOU 4

Enable/Disable VMD

Select Enable to enable Intel Volume Management Device Technology support for the root port specified by the user. The options are Enable and **Disable**.

**If Enable/Disable VMD is set to Enable to a port specified by the user, the following items will display for the port selected.*

VMD Port 5A/5B/5C/5D (Available for onboard NVMe ports only)

Select Enable to enable Intel Volume Management Device Technology support for the root port. The options are Enable and **Disable**.

Hot Plug Capable

Select Enable to enable Hot Plug support for the root ports specified by the user, which will allow the user to change the devices on those root ports without shutting down the system. The options are **Enable** and Disable.

► Intel® VMD for Volume Management Device on CPU2

VMD Config for IOU 0

Enable/Disable VMD

Select Enable to enable Intel Volume Management Device Technology support for the root port specified by the user. The options are Enable and **Disable**.

**If Enable/Disable VMD is set to Enable to a port specified by the user, the following items will display for the port selected.*

VMD Port 1A/1B/1C/1D (Available for onboard NVMe ports only)

Select Enable to enable Intel Volume Management Device Technology support for the root port. The options are Enable and **Disable**.

Hot Plug Capable

Select Enable to enable Hot Plug support for the root ports specified by the user, which will allow the user to change the devices on those root ports without shutting down the system. The options are **Enable** and Disable.

VMD Config for IOU 1

Enable/Disable VMD

Select Enable to enable Intel Volume Management Device Technology support for the root port specified by the user. The options are Enable and **Disable**.

**If Enable/Disable VMD is set to Enable to a port specified by the user, the following items will display for the port selected.*

VMD Port 2A/2B/2C/2D (Available for onboard NVMe ports only)

Select Enable to enable Intel Volume Management Device Technology support for the root port. The options are Enable and **Disable**.

Hot Plug Capable

Select Enable to enable Hot Plug support for the root ports specified by the user, which will allow the user to change the devices on those root ports without shutting down the system. The options are **Enable** and Disable.

VMD Config for IOU 3

Enable/Disable VMD

Select Enable to enable Intel Volume Management Device Technology support for the root port specified by the user. The options are Enable and **Disable**.

**If Enable/Disable VMD is set to Enable to a port specified by the user, the following items will display for the port selected.*

VMD Port 4A/4B/4C/4D (Available for onboard NVMe ports only)

Select Enable to enable Intel Volume Management Device Technology support for the root port. The options are Enable and **Disable**.

Hot Plug Capable

Select Enable to enable Hot Plug support for the root ports specified by the user, which will allow the user to change the devices on those root ports without shutting down the system. The options are **Enable** and Disable.

VMD Config for IOU 4

Enable/Disable VMD

Select Enable to enable Intel Volume Management Device Technology support for the root port specified by the user. The options are Enable and **Disable**.

**If Enable/Disable VMD is set to Enable to a port specified by the user, the following items will display for the port selected.*

VMD Port 5A/5B/5C/5D (Available for onboard NVMe ports only)

Select Enable to enable Intel Volume Management Device Technology support for the root port. The options are Enable and **Disable**.

Hot Plug Capable

Select Enable to enable Hot Plug support for the root ports specified by the user, which will allow the user to change the devices on those root ports without shutting down the system. The options are **Enable** and Disable.

PCI-E ASPM Support (Global)

Use this feature to enable the ASPM support for all downstream devices. The options are **No**, Per-Port and L1 Only.

IIO eDPC (Enhanced Downstream Port Containment) Support

Use this feature to configure the setting for IIO Enhanced Downstream Port Containment (eDPC) support for your system in an effort to improve the error containment capacity within the PCIe subsystem when an uncorrected error is detected either at the root port or at the switch downstream port. Select Disable to disable IIO eDPC support. Select On Fatal Error to enable IIO eDPC support in your system when a fatal error occurs. Select On Fatal and Non-Fatal Error to enable IIO eDPC support when an error, fatal or non-fatal, has occurred. The options are On Fatal Error, On Fatal and Non-Fatal Errors, and **Disable**.

**If this feature is set to On Fatal Error/On Fatal and Non-Fatal Errors, the following features will be displayed:*

IIO eDPC Interrupt (Available when "IIO eDPC Support" is set to On Fatal Error/On Fatal and Non-Fatal Errors)

Select Enable to enable IIO eDPC Interrupt support. The options are **Enabled** and Disable.

IIO eDPC ERR_COR (Error Correction) Message (Available when "IIO eDPC Support" is set to On Fatal Error/On Fatal and Non-Fatal Errors)

If this feature is set to Enable, an IIO eDPC error correction message will be displayed. The options are **Enabled** and Disable.

► South Bridge

The following South Bridge information will display:

- USB Module Version
- USB Devices

Legacy USB Support

Select Enabled to support onboard legacy USB devices. Select Auto to disable legacy support if there are no legacy USB devices present. Select Disable to have all USB devices available for EFI applications only. The options are **Enabled**, Disabled and Auto.

XHCI Hand-Off

This is a work-around solution for operating systems that do not support XHCI (Extensible Host Controller Interface) hand-off. The XHCI ownership change should be claimed by the XHCI driver. The options are Disabled and **Enabled**.

Port 60/64 Emulation

Select Enabled for I/O port 60h/64h emulation support, which in turn, will provide complete legacy USB keyboard support for the operating systems that do not support legacy USB devices. The options are **Disabled** and Enabled.

PCIe PLL SSC

Select Enabled for PCH PCIe Spread Spectrum Clocking support, which will allow the BIOS to monitor and attempt to reduce the level of electromagnetic interference caused by the components whenever needed. The options are Enabled and **Disabled**.

Port 61h Bit-4 Emulation

Select Enabled to enable the emulation of Port 61h bit-4 toggling in SMM (System Management Mode). The options are **Disabled** and Enabled.

► Server ME (Management Engine) Configuration

The following General ME Configuration will display:

- General ME Configuration
- Oper. Firmware Version
- Backup Firmware Version
- Recovery Firmware Version
- ME Firmware Status #1
- ME Firmware Status #2
- Current State
- Error Code

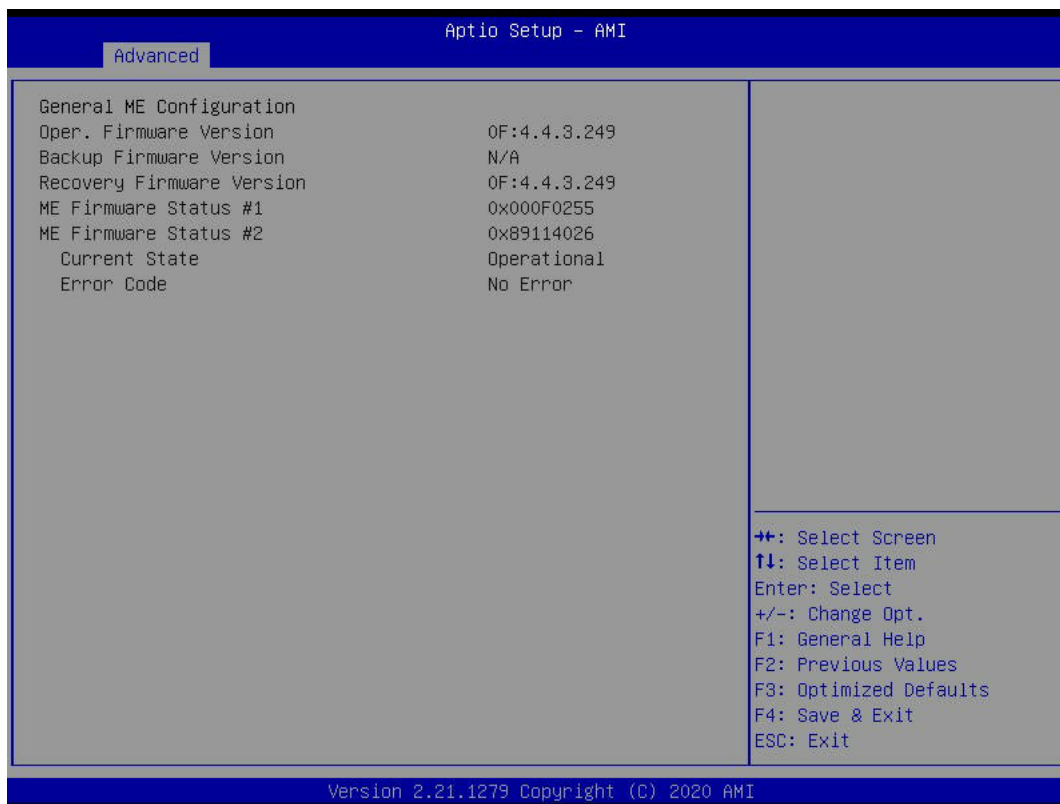

► PCH SATA Configuration

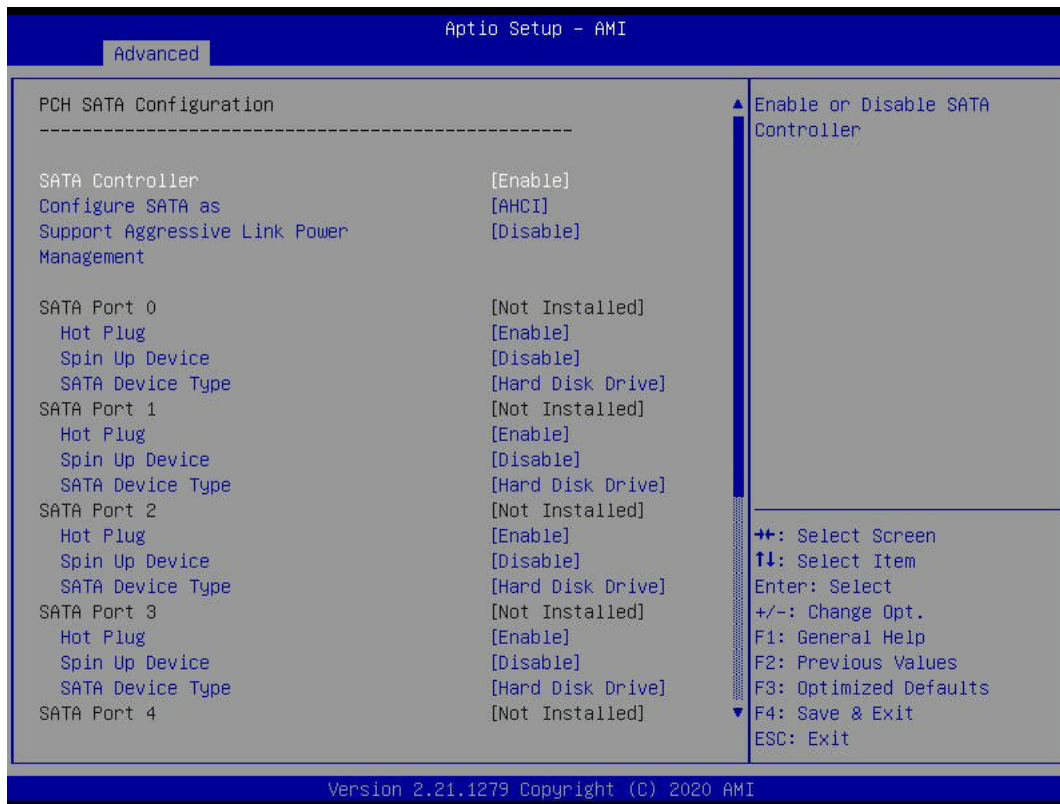

SATA Controller

This feature enables or disables the onboard SATA controller supported by the Intel PCH chip. The options are **Enable** and **Disable**.

Configure SATA as (Available when "SATA Controller" is set to Enable)

Select AHCI to configure a SATA drive specified by the user as an AHCI drive. Select RAID to configure a SATA drive specified by the user as a RAID drive. The options are **AHCI** and **RAID**.

SATA RSTe Boot Info (Available when "Configure SATA as" is set to RAID)

Select Enable for full int13h support which will allow the system to boot using a device attached to the SATA controller. The options are **Disable** and **Enable**.



Note: For this feature to work properly, please set the CSM Storage OPRM policy to Legacy.)

Support Aggressive Link Power Management

When this feature is set to Enable, the SATA AHCI controller manages the power use of the SATA link. The controller will put the link in a low power mode during an extended period of I/O inactivity, and will return the link to an active state when I/O activity resumes. The options are **Enable** and **Disable**.

SATA RAID Option ROM/UEFI Driver (Available when "Configure SATA as" is set to RAID)

Select EFI to load the EFI driver for system boot. Select Legacy to load a legacy driver for system boot. The options are Disable, **EFI**, and Legacy.

SATA Port 0 - SATA Port 7

Hot Plug

Select Enable to support Hot-plugging for the device installed on a selected SATA port which will allow the user to replace the device installed in the slot without shutting down the system. The options are **Enable** and Disable.

Spin Up Device

Select Enable for Staggered Spin Up support which will allow the SATA devices specified by the user to spin up one at a time at boot up in an effort to prevent all hard drive disks from spinning up at the same time, causing a power surge. The options are Enable and **Disable**.

SATA Device Type

Use this feature to specify if the device installed on the SATA port specified by the user should be connected to a Solid State drive or a Hard Disk Drive. The options are **Hard Disk Drive** and Solid State Drive.

► PCH sSATA Configuration

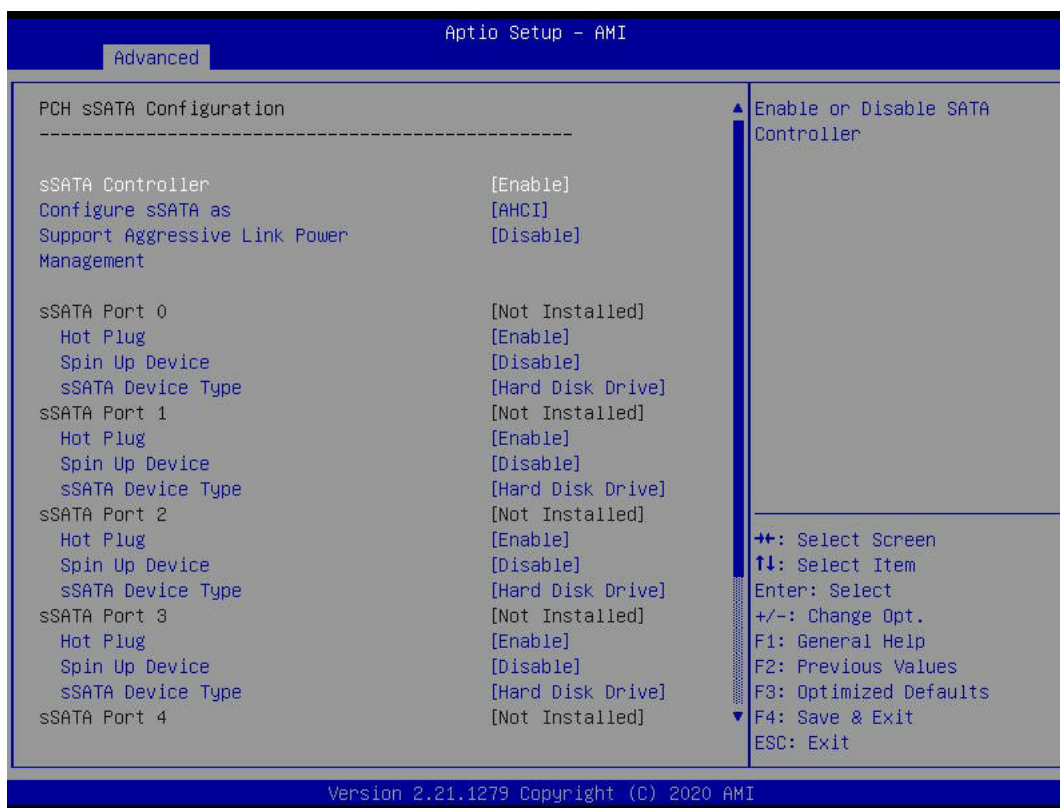

sSATA Controller

This feature enables or disables the onboard sSATA controller supported by the Intel PCH chip. The options are **Enable** and **Disable**.

Configure sSATA as (Available when "SATA Controller" is set to Enable)

Select AHCI to configure a sSATA drive specified by the user as an AHCI drive. Select RAID to configure a sSATA drive specified by the user as a RAID drive. The options are **AHCI** and **RAID**.

sSATA RSTe Boot Info (Available when "Configure sSATA as" is set to RAID)

Select Enable for full int13h support which will allow the system to boot using a device attached to the SATA controller. The options are **Disable** and **Enable**.



Note: For this feature to work properly, please set the CSM Storage OPRM policy to Legacy.)

Support Aggressive Link Power Management

When this feature is set to Enable, the sSATA AHCI controller manages the power use of the sSATA link. The controller will put the link in a low power mode during an extended period of I/O inactivity, and will return the link to an active state when I/O activity resumes. The options are **Enable** and **Disable**.

sSATA RAID Option ROM/UEFI Driver (Available when "Configure sSATA as" is set to RAID)

Select EFI to load the EFI driver for system boot. Select Legacy to load a legacy driver for system boot. The options are Disable, **EFI**, and Legacy.

sSATA Port 0 - sSATA Port 5

Hot Plug

Select Enable to support Hot-plugging for the device installed on a selected SATA port which will allow the user to replace the device installed in the slot without shutting down the system. The options are **Enable** and Disable.

Spin Up Device

Select Enable for Staggered Spin Up support which will allow the sSATA devices specified by the user to spin up one at a time at boot up in an effort to prevent all hard drive disks from spinning up at the same time, causing a power surge. The options are Enable and **Disable**.

sSATA Device Type

Use this feature to specify if the device installed on the sSATA port specified by the user should be connected to a Solid State drive or a Hard Disk Drive. The options are **Hard Disk Drive** and Solid State Drive.

► UEFI Variables Protection



Password Protection of Runtime Variables

Use this feature to enable or disable the NVRAM Runtime Variable protection through system admin password. The options are Disabled and **Enabled**.

► Network Configuration

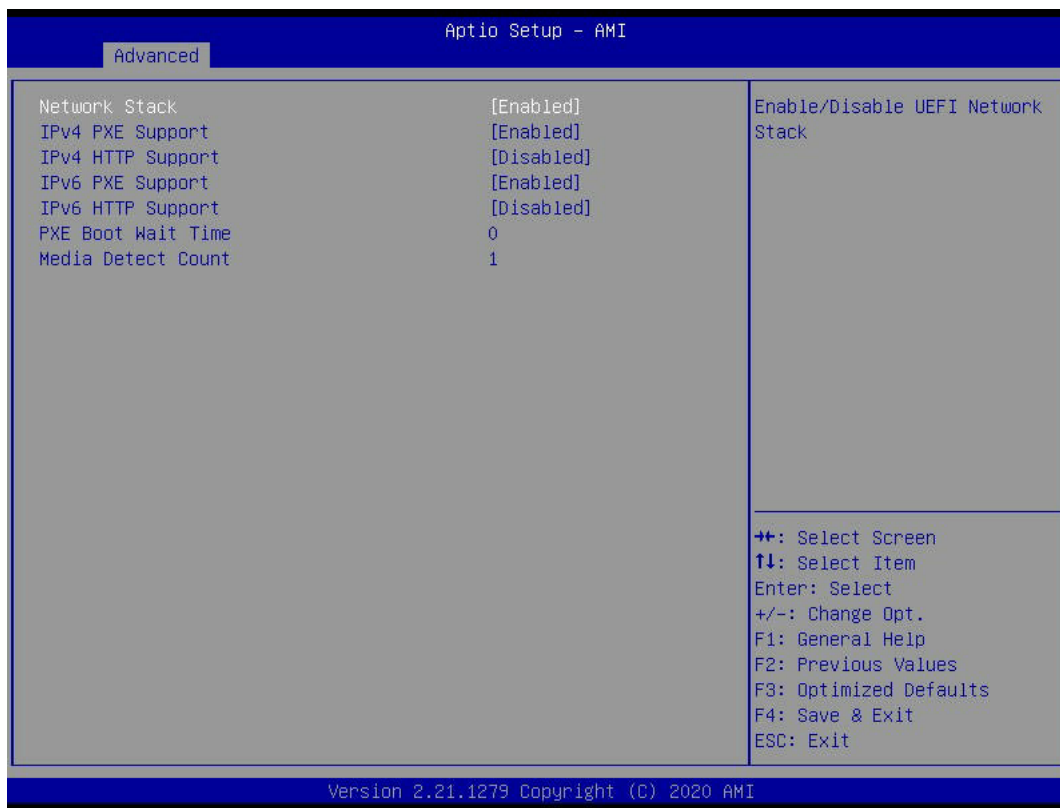

Network Stack

Select Enabled to enable PXE (Preboot Execution Environment) or UEFI (Unified Extensible Firmware Interface) for network stack support. The options are **Enabled** and Disabled.

**If "Network Stack" is set to Enabled, the following items will display:*

IPv4 PXE Support

Select Enabled to enable IPv4 PXE boot support. If this feature is disabled, it will not create the IPv4 PXE boot option. The options are Disabled and **Enabled**.

IPv4 HTTP Support

Select Enabled to enable IPv4 HTTP boot support. If this feature is disabled, it will not create the IPv4 HTTP boot option. The options are Enabled and **Disabled**.

IPv6 PXE Support

Select Enabled to enable IPv4 PXE boot support. If this feature is disabled, it will not create the IPv6 PXE boot option. The options are Disabled and **Enabled**.

IPv6 HTTP Support

Select Enabled to enable IPv4 HTTP boot support. If this feature is disabled, it will not create the IPv6 HTTP boot option. The options are Enabled and **Disabled**.

PXE Boot Wait Time

Use this feature to set the wait time (in seconds) upon which the system BIOS will wait for user to press the <ESC> key to abort PXE boot instead of proceeding with PXE boot by connecting to a network server immediately. The default is **0**.

Media detect count

Use this feature to select the wait time (in seconds) for the BIOS ROM to detect the presence of a LAN media either via the Internet connection or via a LAN port. The default is **1**.

► KMIP Server Configuration

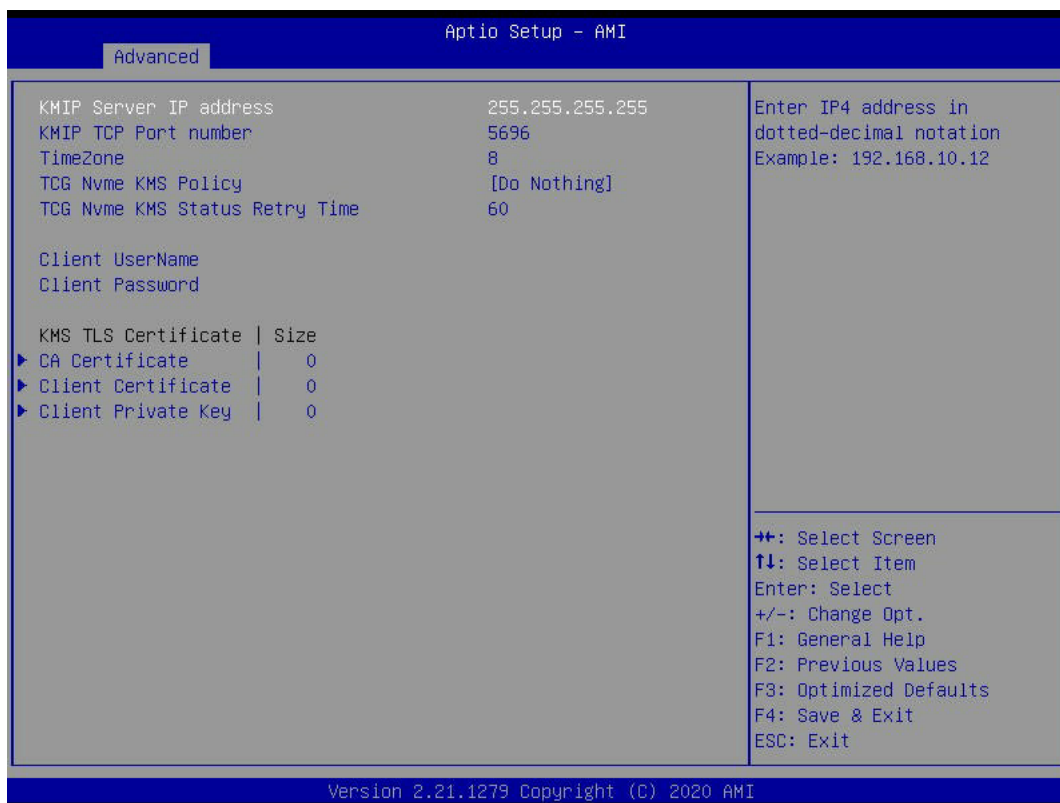

This feature displays the configuration settings for the KMIP (Key Management Interoperability Protocol) server, which will allow the clients to ask a server to encrypt or decrypt data without a direct access key.

KMIP Server IP Address

This feature displays the IP address for the KMIP server.

KMIP TCP Port Number

This feature displays the KMIP TCP Port number.

TimeZone

This feature displays the time zone where the KMIP server is located at.

TCG Nvme KMS Policy

Use this feature to select the TCG NVMe KMS key policy. The options are Normal Unlock, **Do Nothing**, Reset All Devices and Delete Key Id List.

TCG Nvme KMS Status Retry Time

Use this feature to enter the retry time for connection test to key manage server. The system attempts to test connection to the key manage server up to the number of seconds set by the user. The default value is **60**.

Client UserName

Use this feature to enter a username for the KMIP server.

Client Password

Use this feature to enter a password for the KMIP server.

KMS TLS Certificate | Size

This feature displays the Transport Layer Security (TLS) Certificate and its size.

► PCIe/PCI/PnP Configuration

The following information will display:

- PCI Bus Driver Version
- PCI Devices Common Settings:

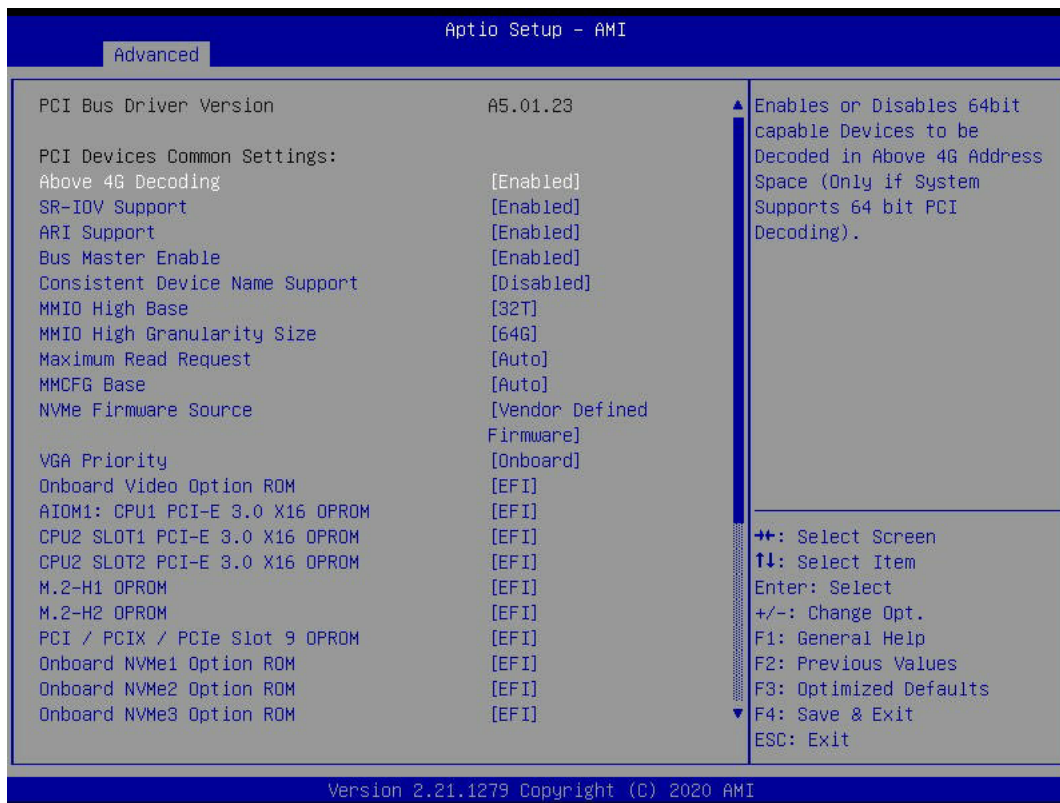

Above 4G Decoding (Available if the system supports 64-bit PCI decoding)

Select Enabled to decode a PCI device that supports 64-bit in the space above 4G Address. The options are **Enabled** and Disabled.

SR-IOV Support (Available if the system supports Single-Root Virtualization)

Select Enabled for Single-Root IO Virtualization support. The options are **Enabled** and Disabled.

ARI Support

Select Enable for Alternative Routing-ID Interpretation (ARI) support. The options are **Enable** and Disable.

Bus Master Enable

Select Enable to disable the Bus Master Attribute for Pre-Boot DMA Protection. The options are **Enable** and Disable.

Consistent Device Name Support

Use this feature to enable the ACPI _DSM device name support for onboard devices and slots. The options are **Disabled** and Enabled.

MMIO High Base

Use this feature to select the base memory size according to memory-address mapping for the IO hub. The options are 56T, 40T, **32T**, 24T, 16T, 4T, 2T, 1T, 512 G.

MMIO High Granularity Size

Use this feature to select the high memory size according to memory-address mapping for the IO hub. The options are 1G, 4G, 16G, **64G**, 256G, and 1024G.

Maximum Read Request

Select Auto for the system BIOS to automatically set the maximum size for a read request for a PCIe device to enhance system performance. The options are **Auto**, 128 Bytes, 256 Bytes, 512 Bytes, 1024 Bytes, 2048 Bytes, and 4096 Bytes.

MMCFG Base

This feature determines how the lowest MMCFG (Memory-Mapped Configuration) base is assigned to onboard PCI devices. The options are 1G, 1.5G, 1.75G, 2G, 2.25G, 3G and **Auto**.

MVMe Firmware Source

This feature determines the source of M.2 drive EFI OpROM/firmware. The options are **Vendor defined Firmware** and AMI Native Support.

VGA Priority

Use this feature to select the graphics device to be used as the primary video display for system boot. The options are **Onboard** and Offboard.

Onboard Video Option ROM

Select UEFI to allow the user to boot the computer using the UEFI (Unified Extensible Firmware Interface) device installed on the onboard video port. Select Legacy to allow the user to boot the computer using a legacy device installed on the onboard video port. The options are Disabled and **UEFI**.

AIOM1: CPU1 PCI-E 3.0 x16 OPROM/CPU2 SLOT1 PCI-E 3.0 x16 OPROM/CPU2 SLOT2 PCI-E 3.0 x16 OPROM

Select EFI to allow the user to boot the computer using an EFI (Extensible Firmware Interface) device installed on the PCIe slot specified by the user. Select Legacy to boot the computer using a legacy device installed on the PCIe slot specified by the user. The options are Disabled and **EFI**.

M.2-H1 OPROM/M.2-H2 OPROM

Select EFI to allow the user to boot the computer using an EFI (Extensible Firmware Interface) device installed on the NVMe connector specified by the user. Select Legacy to boot the computer using a legacy device installed on the NVME connector specified by the user. The options are Disabled and **EFI**.

PCI/PCIX/PCIe Slot 9 OPROM

Select EFI to allow the user to boot the computer using an EFI (Extensible Firmware Interface) device installed on the PCIe slot specified by the user. Select Legacy to boot the computer using a legacy device installed on the PCIe slot specified by the user. The options are Disabled and **EFI**.

Onboard NVMe1 Option ROM/Onboard NVMe2 Option ROM/Onboard NVMe3 Option ROM/Onboard NVMe4 Option ROM/Onboard NVMe5 Option ROM/Onboard NVMe6 Option ROM/Onboard NVMe7 Option ROM/Onboard NVMe8 Option ROM/Onboard NVMe9 Option ROM/Onboard NVMe10 Option ROM/Onboard NVMe11 Option ROM/Onboard NVMe12 Option ROM

Select EFI to allow the user to boot the computer using an EFI (Extensible Firmware Interface) device installed on the NVMe connector specified by the user. Select Legacy to boot the computer using a legacy device installed on the NVME connector specified by the user. The options are Disabled and **EFI**.

► Super IO Configuration

The following Super IO information will display:

- Super IO Chip AST2600

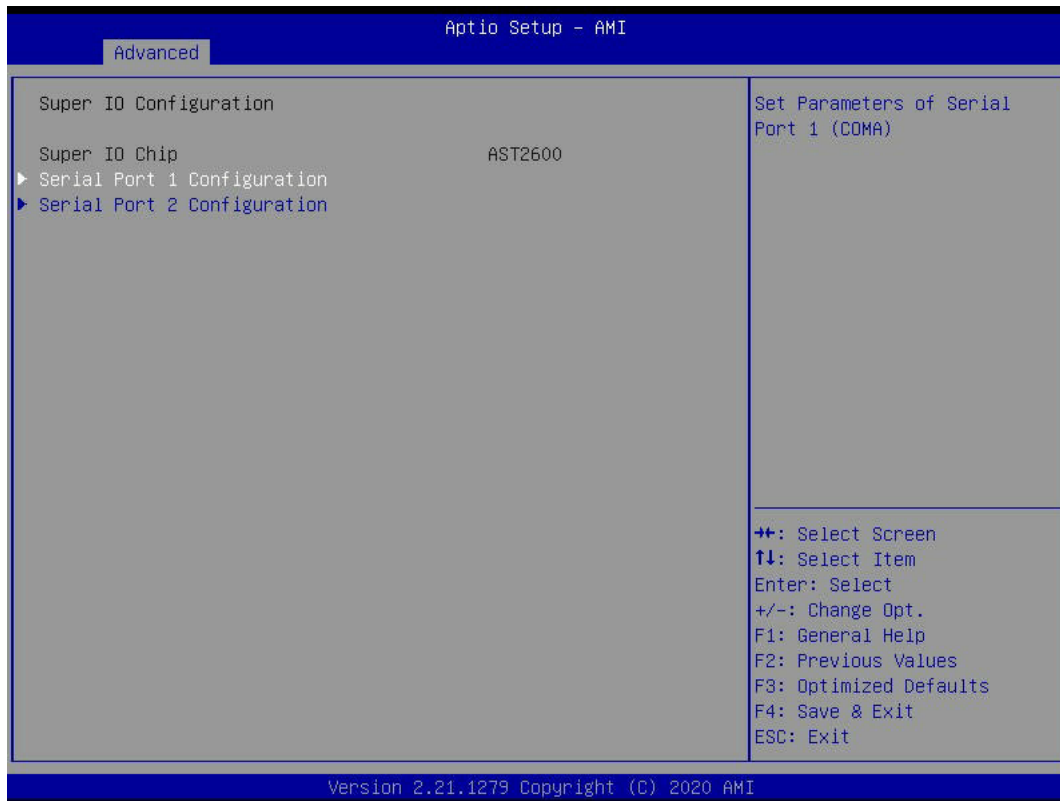

► Serial Port 1 Configuration

Serial Port 1

Select Enabled to enable Serial Port 1. The options are **Enabled** and Disabled.

Device Settings (Available when "Serial Port 1" is set to Enabled)

This feature displays the base I/O port address and the Interrupt Request address of Serial Port 1.

Change Settings (Available when "Serial Port 1" is set to Enabled)

This feature specifies the base I/O port address and the Interrupt Request address of Serial Port 1. Select **Auto** for the BIOS to automatically assign the base I/O and IRQ address to Serial Port 1. The options for Serial Port 1 are **Auto**, (IO=3F8h; IRQ=4;), (IO=2F8h; IRQ=4;), (IO=3E8h; IRQ=4;) and (IO=2E8h; IRQ=4;).

► Serial Port 2 Configuration

Serial Port

Select Enabled to enable Serial Port 2. The options are **Enabled** and Disabled.

Device Settings (Available when "Serial Port 2" is set to Enabled)

This feature displays the base I/O port address and the Interrupt Request address of Serial Port 2.

Change Settings (Available when "Serial Port 2" is set to Enabled)

This feature specifies the base I/O port address and the Interrupt Request address of Serial Port 2. Select Auto for the BIOS to automatically assign the base I/O and IRQ address to Serial Port 2. The options for SOL are **Auto**, (IO=3F8h; IRQ=3;), (IO=2F8h; IRQ=3;), (IO=3E8h; IRQ=3;) and (IO=2E8h; IRQ=3;).

Serial Port 2 Attribute

Select SOL to use Serial Port 2 as a Serial_Over_LAN (SOL) port for console redirection. The options are COM and **SOL**.

► Serial Port Console Redirection



COM1

Console Redirection

Select Enabled to enable COM Port 1 for Console Redirection, which will allow a client machine to be connected to a host machine at a remote site for networking. The options are Enabled and **Disabled**.

*If the item above is set to Enabled, the following items will become available for configuration:

► Console Redirection Settings

Terminal Type

Use this feature to select the target terminal emulation type for Console Redirection. Select VT100 to use the ASCII Character set. Select VT100+ to add color and function key support. Select ANSI to use the Extended ASCII Character Set. Select VT-UTF8 to use UTF8 encoding to map Unicode characters into one or more bytes. The options are ANSI, VT100, **VT100+**, and VT-UTF8.

Bits Per second

Use this feature to set the transmission speed for a serial port used in Console Redirection. Make sure that the same speed is used in the host computer and the client computer. A lower transmission speed may be required for long and busy lines. The options are 9600, 19200, 38400, 57600 and **115200** (bits per second).

Data Bits

Use this feature to set the data transmission size for Console Redirection. The options are 7 (Bits) and **8 (Bits)**.

Parity

A parity bit can be sent along with regular data bits to detect data transmission errors. Select Even if the parity bit is set to 0, and the number of 1's in data bits is even. Select Odd if the parity bit is set to 0, and the number of 1's in data bits is odd. Select None if you do not want to send a parity bit with your data bits in transmission. Select Mark to add a mark as a parity bit to be sent along with the data bits. Select Space to add a Space as a parity bit to be sent with your data bits. The options are **None**, Even, Odd, Mark, and Space.

Stop Bits

A stop bit indicates the end of a serial data packet. Select 1 Stop Bit for standard serial data communication. Select 2 Stop Bits if slower devices are used. The options are **1** and **2**.

Flow Control

Use this feature to set the flow control for Console Redirection to prevent data loss caused by buffer overflow. Send a "Stop" signal to stop sending data when the receiving buffer is full. Send a "Start" signal to start sending data when the receiving buffer is empty. The options are **None** and Hardware RTS/CTS.

VT-UTF8 Combo Key Support

Select Enabled to enable VT-UTF8 Combination Key support for ANSI/VT100 terminals. The options are **Enabled** and Disabled.

Recorder Mode

Select Enabled to capture the data displayed on a terminal and send it as text messages to a remote server. The options are **Disabled** and Enabled.

Resolution 100x31

Select Enabled for extended-terminal resolution support. The options are Disabled and **Enabled**.

Legacy OS Redirection Resolution

Use this feature to select the number of rows and columns used in Console Redirection for Legacy OS support. The options are 80x24 and **80x25**.

Putty KeyPad

This feature selects Function Keys and KeyPad settings for Putty, which is a terminal emulator designed for the Windows OS. The options are **VT100**, LINUX, XTERMR6, SCO, ESCN, and VT400.

Redirection After BIOS Post

Use this feature to enable or disable Legacy Console Redirection after BIOS POST. When the option - Bootloader is selected, Legacy Console Redirection is disabled before booting the OS. When the option - Always Enable is selected, Legacy Console Redirection remains enabled upon OS bootup. The options are **Always Enable** and Bootloader.

COM1 Bits Per Second

Use this feature to set the transmission speed for a serial port used in Console Redirection. Make sure that the same speed is used in the host computer and the client computer. A lower transmission speed may be required for long and busy lines. The options are 9600, 19200, 38400, 57600 and **115200** (bits per second).

SOL (Serial-Over-LAN)

Console Redirection (for SOL)

Select Enabled to use the SOL port for Console Redirection. The options are **Enabled** and Disabled.

*If the feature above is set to Enabled, the following items will become available for configuration:

► Console Redirection Settings (for SOL)

Terminal Type

Use this feature to select the target terminal emulation type for Console Redirection. Select VT100 to use the ASCII Character set. Select VT100+ to add color and function key support. Select ANSI to use the Extended ASCII Character Set. Select VT-UTF8 to use UTF8 encoding to map Unicode characters into one or more bytes. The options are ANSI, VT100, **VT100+**, and VT-UTF8.

Bits Per second

Use this feature to set the transmission speed for a serial port used in Console Redirection. Make sure that the same speed is used in the host computer and the client computer. A lower transmission speed may be required for long and busy lines. The options are 9600, 19200, 38400, 57600 and **115200** (bits per second).

Data Bits

Use this feature to set the data transmission size for Console Redirection. The options are 7 (Bits) and **8 (Bits)**.

Parity

A parity bit can be sent along with regular data bits to detect data transmission errors. Select Even if the parity bit is set to 0, and the number of 1's in data bits is even. Select Odd if the parity bit is set to 0, and the number of 1's in data bits is odd. Select None if you do not want to send a parity bit with your data bits in transmission. Select Mark to add a mark as a parity bit to be sent along with the data bits. Select Space to add a Space as a parity bit to be sent with your data bits. The options are **None**, Even, Odd, Mark, and Space.

Stop Bits

A stop bit indicates the end of a serial data packet. Select 1 Stop Bit for standard serial data communication. Select 2 Stop Bits if slower devices are used. The options are **1** and 2.

Flow Control

Use this feature to set the flow control for Console Redirection to prevent data loss caused by buffer overflow. Send a "Stop" signal to stop sending data when the receiving buffer is full. Send a "Start" signal to start sending data when the receiving buffer is empty. The options are **None** and Hardware RTS/CTS.

VT-UTF8 Combo Key Support

Select Enabled to enable VT-UTF8 Combination Key support for ANSI/VT100 terminals. The options are **Enabled** and Disabled.

Recorder Mode

Select Enabled to capture the data displayed on a terminal and send it as text messages to a remote server. The options are **Disabled** and Enabled.

Resolution 100x31

Select Enabled for extended-terminal resolution support. The options are Disabled and **Enabled**.

Legacy OS Redirection Resolution

Use this feature to select the number of rows and columns used in Console Redirection for Legacy OS support. The options are 80x24 and **80x25**.

Putty KeyPad

This feature selects Function Keys and KeyPad settings for Putty, which is a terminal emulator designed for the Windows OS. The options are **VT100**, LINUX, XTERMR6, SCO, ESCN, and VT400.

Redirection After BIOS Post

Use this feature to enable or disable Legacy Console Redirection after BIOS POST. When the option - Bootloader is selected, Legacy Console Redirection is disabled before booting the OS. When the option - Always Enable is selected, Legacy Console Redirection remains enabled upon OS bootup. The options are **Always Enable** and Bootloader.

Serial Port for Out-of-Band Management/Windows Emergency Management Services (EMS)

The feature allows the user to configure Console Redirection settings to support Out-of-Band Serial Port management.

Console Redirection (for EMS)

Select Enabled to use a COM port specified by the user for EMS Console Redirection. The options are Enabled and **Disabled**.

*If the feature above is set to Enabled, the following items will become available for user's configuration:

► Console Redirection Settings (for EMS)

Out-of-Band Management Port

This feature selects a serial port in a client server to be used by the Windows Emergency Management Services (EMS) to communicate with a remote host server. The options are **COM1** and COM2/SOL (Console Redirection).

Terminal Type

Use this feature to select the target terminal emulation type for Console Redirection. Select VT100 to use the ASCII character set. Select VT100+ to add color and function key support. Select ANSI to use the extended ASCII character set. Select VT-UTF8 to use UTF8 encoding to map Unicode characters into one or more bytes. The options are ANSI, VT100, VT100+, and **VT-UTF8**.

Bits Per Second

This feature sets the transmission speed for a serial port used in Console Redirection. Make sure that the same speed is used in both host computer and the client computer. A lower transmission speed may be required for long and busy lines. The options are 9600, 19200, 57600, and **115200** (bits per second).

Flow Control

Use this feature to set the flow control for Console Redirection to prevent data loss caused by buffer overflow. Send a "Stop" signal to stop data-sending when the receiving buffer is full. Send a "Start" signal to start data-sending when the receiving buffer is empty. The options are **None**, Hardware RTS/CTS, and Software Xon/Xoff.

The setting for each of these features is displayed:

- Data Bits
- Parity
- Stop Bits

► ACPI Settings

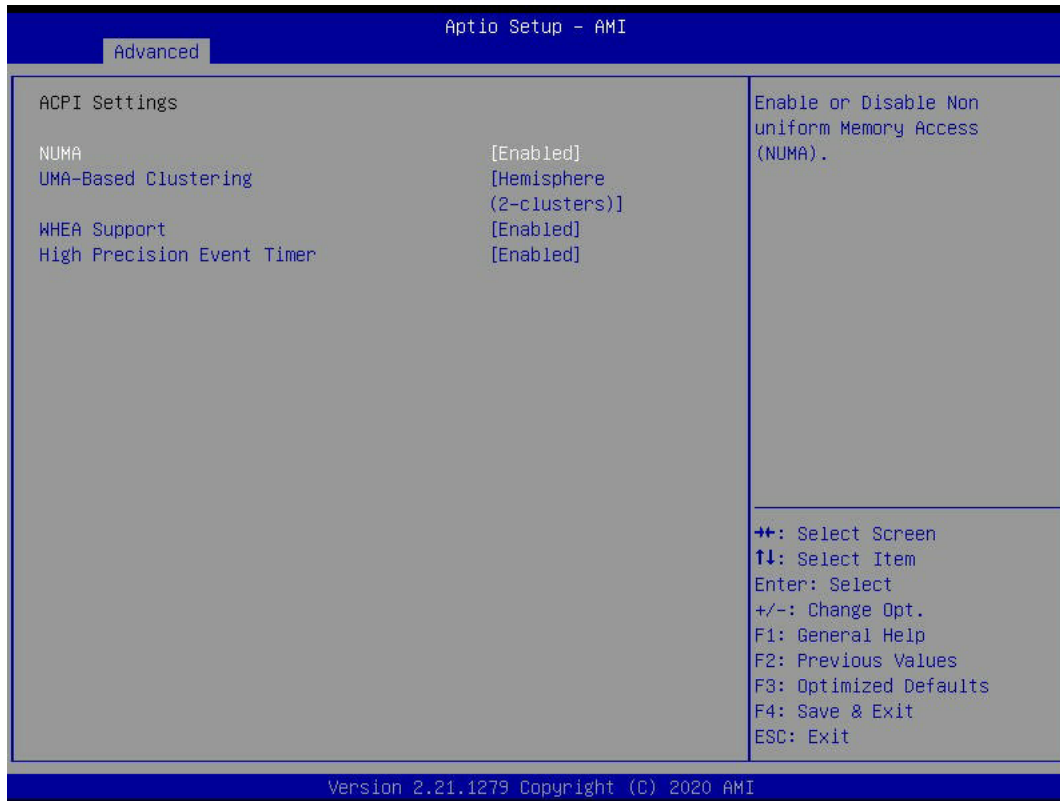

Use this feature to configure Advanced Configuration and Power Interface (ACPI) power management settings for your system.

NUMA

Select Enabled to enable Non-Uniform Memory Access support to enhance system performance. The options are **Enabled** and Disabled.

UMA-Based Clustering

Use this feature to select the UMA (Uniform Memory Access) Based Clustering option. The options are **Hemisphere (20clusters)** and Disabled (All2All).

WHEA Support

Select Enabled to support the Windows Hardware Error Architecture (WHEA) platform and provide a common infrastructure for the system to handle hardware errors within the Windows OS environment to reduce system crashes and to enhance system recovery and health monitoring. The options are **Enabled** and Disabled.

High Precision Event Timer

Select Enabled to enable High Precision Event Timer. The options are **Enable** and Disable.

► Trusted Computing

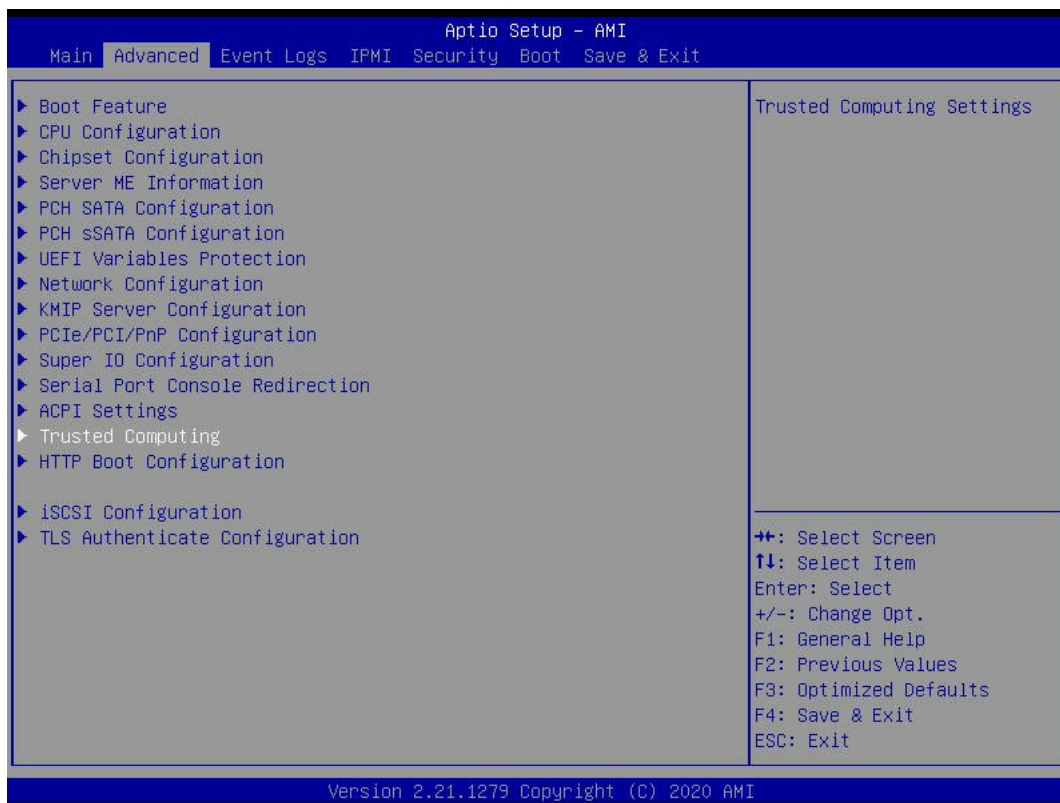

When a TPM (Trusted-Platform Module) device is detected in your machine, the following information will display:

- TPM 2.0 Device Found:
- Firmware Version:
- Vendor:

TPM v1.2 Support

Select Enable to enable TPM (Trusted Platform Module) 2.0 support to enhance system integrity and data security. If there is a TPM jumper installed on the motherboard, please also enable the jumper for this feature to work properly. Please note that the OS will not show the security device when this feature is set to Enabled. Neither TCG EFI protocol nor INT1A interaction will be available for use. If you have made changes on the setting of this feature, be sure to reboot the system for the change to take effect. The options are Disable and **Enable**.

*If this option is set to Enable, the following screen and items will display:

- Active PCR Banks
- Available PCR Banks

SHA-1 PCR Bank

Select Enabled to enable SHA-1 PCR Bank support to enhance system integrity and data security. The options are **Enabled** and Disabled.

SHA256 PCR Bank

Select Enabled to enable SHA256 PCR Bank support to enhance system integrity and data security. The options are **Enabled** and Disabled.

Pending Operation

Use this feature to schedule a TPM-related operation to be performed by a security (TPM) device at the next system boot to enhance system data integrity. Your system will reboot to carry out a pending TPM operation. The options are **None** and TPM Clear.



Note: Your system will reboot to carry out a pending TPM operation.

Platform Hierarchy (for TPM Version 2.0 and above)

Select Enabled for TPM Platform Hierarchy support which will allow the manufacturer to utilize the cryptographic algorithm to define a constant key or a fixed set of keys to be used for initial system boot. These early boot codes are shipped with the platform and are included in the list of "public keys". During system boot, the platform firmware uses the trusted public keys to verify a digital signature in an attempt to manage and control the security of the platform firmware used in a host system via a TPM device. The options are **Enabled** and Disabled.

Storage Hierarchy

Select Enabled for TPM Storage Hierarchy support that is intended to be used for non-privacy-sensitive operations by a platform owner such as an IT professional or the end user. Storage Hierarchy has an owner policy and an authorization value, both of which can be set and are held constant (-rarely changed) through reboots. This hierarchy can be cleared or changed independently of the other hierarchies. The options are **Enabled** and Disabled.

Endorsement Hierarchy

Select Enabled for Endorsement Hierarchy support, which contains separate controls to address the user's privacy concerns because the primary keys in the hierarchy are certified by the TPM key or by a manufacturer with restrictions on how an authentic TPM device that is attached to an authentic platform can be accessed and used. A primary key can be encrypted and certified with a certificate created by using TPM2_ActivateCredential, which allows the user to independently enable "flag, policy, and authorization values" without involving other hierarchies. A user with privacy concerns can disable the endorsement

hierarchy while still using the storage hierarchy for TPM applications, permitting the platform software to use the TPM. The options are **Enabled** and Disabled.

PH (Platform Hierarchy) Randomization (for TPM Version 2.0 and above)

Select Enabled for Platform Hierarchy Randomization support, which is used only during the platform developmental stage. This feature cannot be enabled in the production platforms. The options are **Disabled** and Enabled.

TXT Support

Select Enabled to enable Intel Trusted Execution Technology (TXT) support to enhance system integrity and data security. The options are **Disabled** and Enabled.



Note 1: If the option for this feature (TXT Support) is set to Enabled, be sure to disable EV DFX (Device Function On-Hide support when it is present in the BIOS for the system to work properly

Note 2: For more information on TPM, please refer to the TPM manual at <http://www.supermicro.com/manuals/other>.

► HTTP Boot Configuration

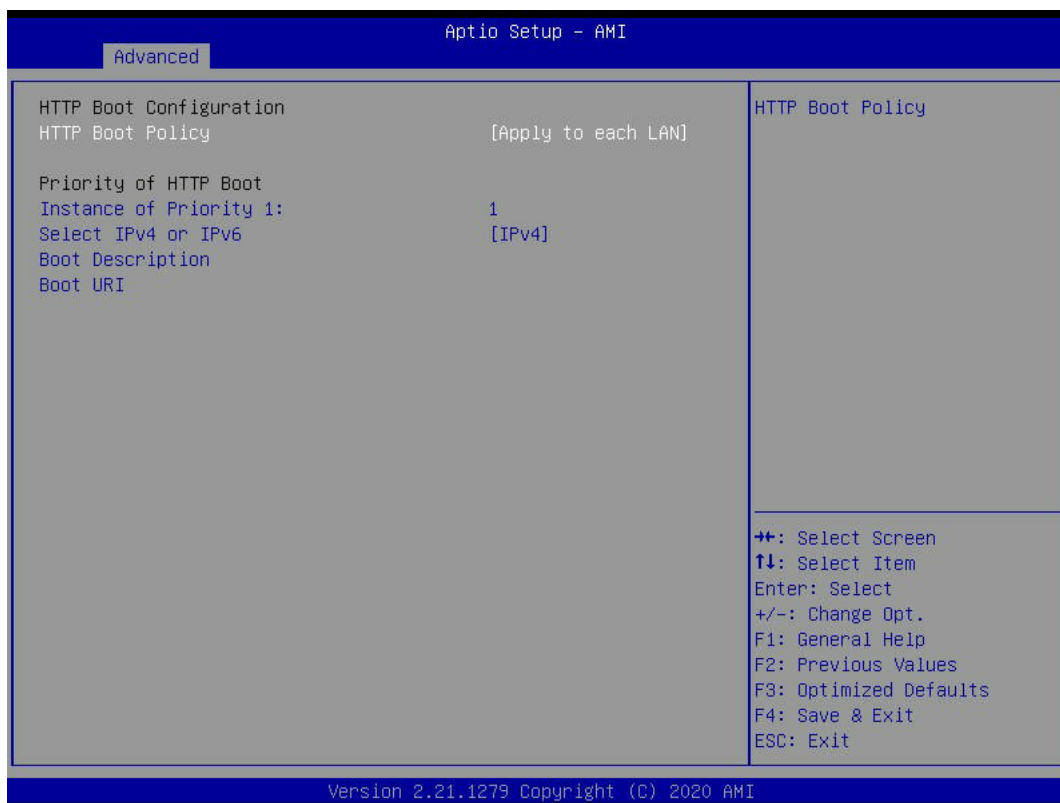

HTTP Boot Configuration

HTTP Boot Policy

Use this feature to set the HTTP Boot policy. The options are Apply to all LANs, **Apply to Each LAN**, and Boot Priority #1 instantly.

Priority of HTTP Boot

Instance of Priority 1:

This feature sets the rank target port. The default setting is **1**.

Select IPv4 or IPv6

This feature specifies which connection the target LAN port should boot from. Select IPv4 to boot the target LAN from IPv4. The options are **IPv4** and IPv6.

Boot Description

Use this feature to enter a boot description, which cannot be longer than 75 characters. Please be sure to enter a boot description; otherwise, the boot option for the URI cannot be created.

Boot URI (Uniform Research Identifier)

Enter a Boot URI with 128 characters or shorter. This Boot URI determines how IPv4 Boot Option & IPv6 Boot Option will be created. This feature is only supported on Dual or EFI Boot Mode.

Instance of Priority 2:

This feature sets the rank target port. The default setting is **0**.

► iSCSI Configuration

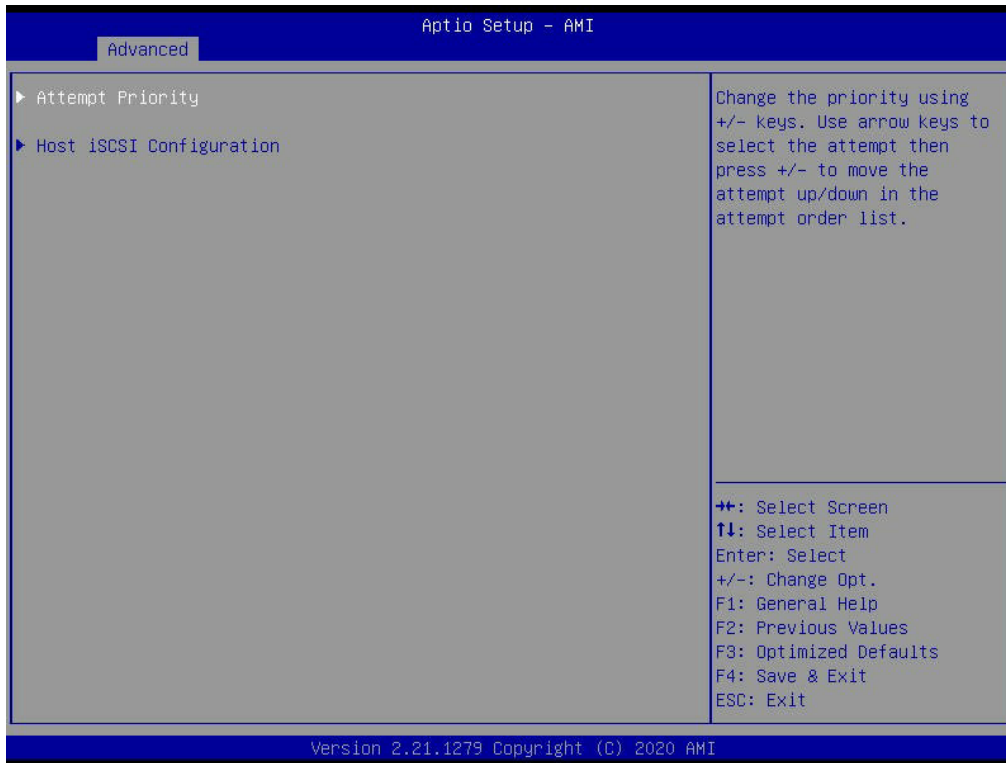

► Attempt Priority

Attempt Priority

Use this feature to change the priority of iSCSI attempts using the + or - keys. The options are **Host Attempt**, Redfish Attempt, and Rsd Attempt.

Commit Changes and Exit

Select this feature to save the changes you've made and exit from the program.

► Host iSCSI Configuration

iSCSI Initiator Name

► Add an Attempt

► Delete Attempts

► Change Attempt Order



Note: For detailed instructions on how to configure iSCSI settings, please refer to the iSCSI Configuration User's Guide posted on the web page under the link: <http://www.supermicro.com/support/manuals/>.

► TLS Authentication Configuration

This submenu allows the user to configure Transport Layer Security (TLS) settings.



► Server CA Configuration

This feature allows the user to configure the client certificate that is to be used by the server.

► Enroll Cert

This feature allows the user to enroll the certificate in the system.

► Enroll Cert (Certification) Using File

This feature allows the user to enroll the security certificate in the system by using a file.

Cert (Certification) GUID (Global Unique Identifier)

This feature displays the GUID for this system.

► Commit Changes and Exit

Select this feature to save the changes you have made and exit from the system.

▶Discard Changes and Exit

Select this feature to discard the changes you have made and exit from the system.

▶Delete Certification

If this feature is set to Enable, the certificate enrolled in the system will be deleted. The options are Enable and **Disable**.

▶Client Certification Configuration

This feature allows the user to configure the client certificate to be used by the server.

▶Enroll Certification

This feature allows the user to enroll the certificate in the system.

▶Enroll Cert (Certification) Using File

This feature allows the user to enroll the security certificate in the system by using a file.

Cert (Certification) GUID (Global Unique Identifier)

This feature displays the GUID for this system.

▶Commit Changes and Exit

Select this feature to save the changes you have made and exit from the system.

▶Discard Changes and Exit

Select this feature to discard the changes you have made and exit from the system.

▶Delete Certification

If this feature is set to Enable, the certificate enrolled in the system will be deleted. The options are Enable and **Disable**.

4.4 Event Logs

Use this feature to configure Event Log settings.

 **Note:** After you've made any changes on a setting below, please reboot the system for the changes you've made to take effect.

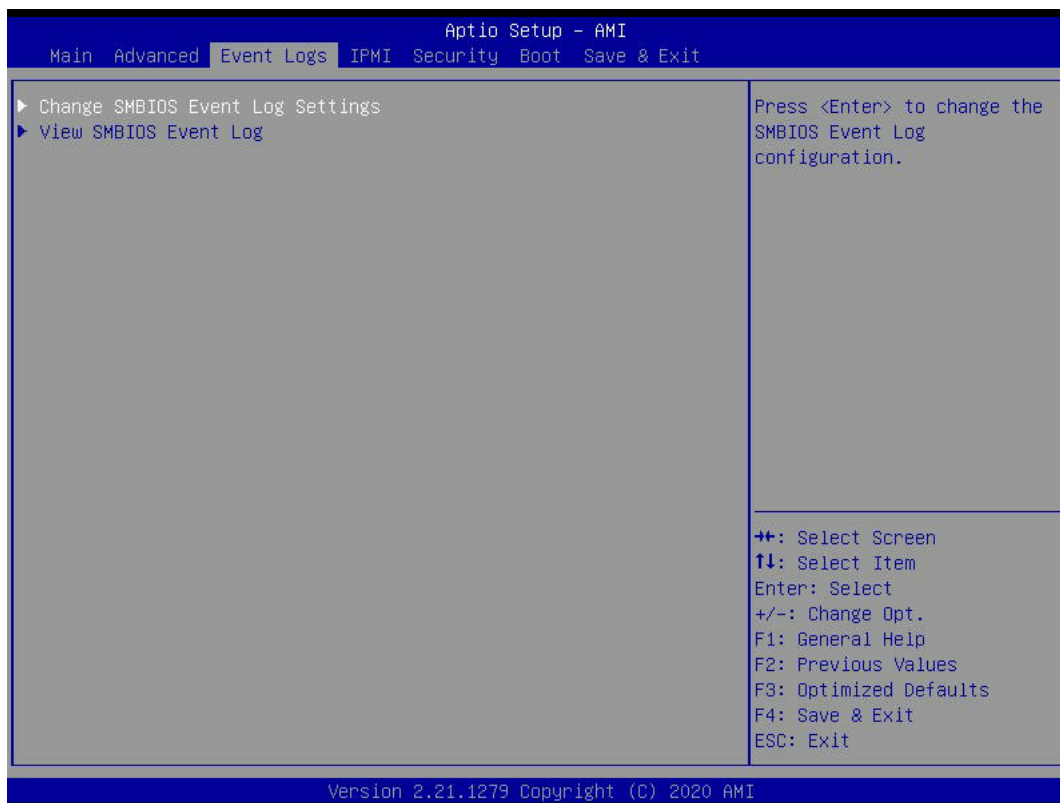

► Change SMBIOS Event Log Settings

Enabling/Disabling Options

SMBIOS Event Log

Select Enabled to enable SMBIOS (System Management BIOS) Event Logging during system boot. The options are **Enabled** and Disabled.

Erasing Settings

Erase Event Log

Select "No" to keep the event log without erasing it upon next system bootup. Select "Yes, Next Reset" to erase the event log upon next system reboot. The options are **"No"**, "Yes, Next Reset", and "Yes, Every Reset".

When Log is Full

Select Erase Immediately to immediately erase all errors in the SMBIOS event log when the event log is full. Select Do Nothing for the system to do nothing when the SMBIOS event log is full. The options are **Do Nothing** and Erase Immediately.

SMBIOS Event Log Standard Settings**Log System Boot Event**

Select Enabled to log system boot events. The options are Enabled and **Disabled**.

MECI (Multiple Event Count Increment)

Enter the increment value for the multiple event counter. Enter a number between 1 to 255. The default setting is **1**.

METW (Multiple Event Count Time Window)

This feature is used to determine how long (in minutes) should the multiple event counter wait before generating a new event log. Enter a number between 0 to 99. The default setting is **60**.

►View SMBIOS Event Log

Select this submenu and press enter to see the contents of the SMBIOS event log. The following categories will be displayed: Date/Time/Error Codes/Severity.

4.5 BMC

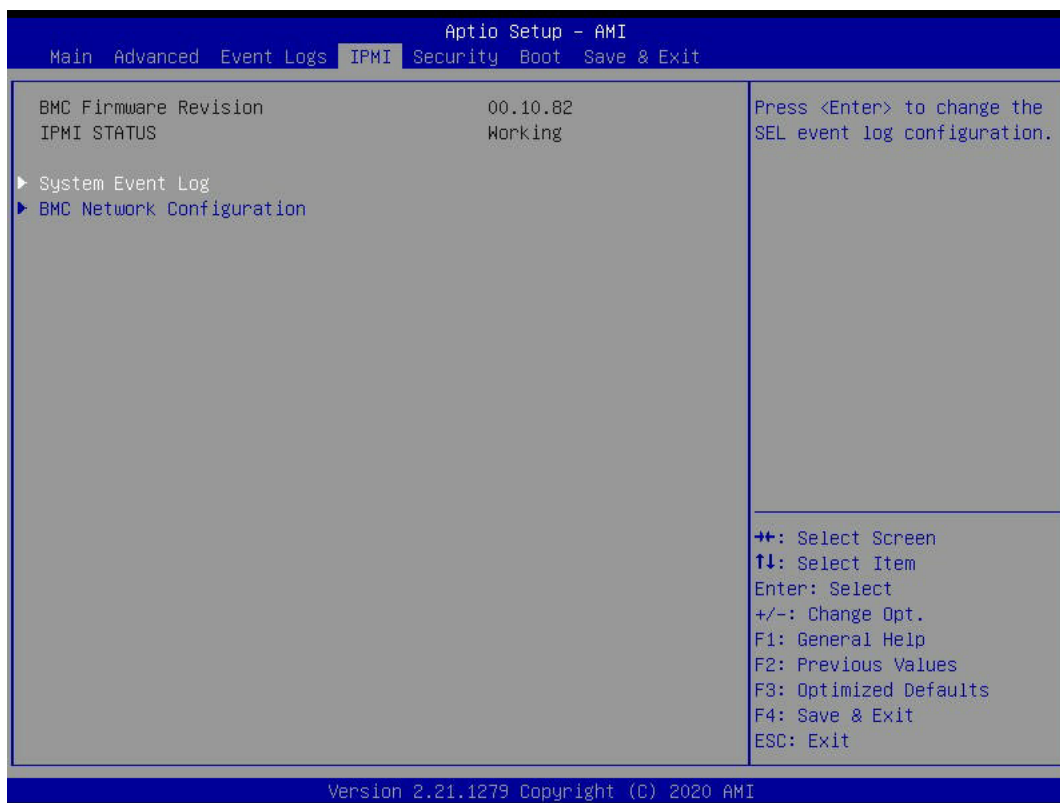

Use this feature to configure Intelligent Platform Management Interface (BMC) settings.

BMC Firmware Revision

This item indicates the BMC firmware revision used in your system.

Status Of BMC (Baseboard Management Controller)

This item indicates the status of the BMC firmware installed in your system.

▶ System Event Log

Enabling/Disabling Options

SEL Components

Select Enabled for all system event logging at bootup. The options are **Enabled** and Disabled.

Erasing Settings

Erase SEL

Select Yes, On next reset to erase all system event logs upon next system reboot. Select Yes, On every reset to erase all system event logs upon each system reboot. Select No to

keep all system event logs after each system reboot. The options are **No**, Yes, On next reset, and Yes, On every reset.

When SEL is Full

This feature allows the user to decide what the BIOS should do when the system event log is full. Select Erase Immediately to erase all events in the log when the system event log is full. The options are **Do Nothing** and Erase Immediately.



Note: After making changes on a setting, be sure to reboot the system for the changes to take effect.

► BMC Network Configuration

Update BMC LAN Configuration

Select Yes for the BIOS to implement all IP/MAC address changes upon next system boot. The options are **No** and Yes.

Configure IPV4 Support

This section displays configuration features for IPV4 support.

BMC LAN Selection

This item displays the BMC LAN setting. The default setting is **Failover**.

BMC Network Link Status

This item displays the BMC Network Link status. The default setting is **Dedicated LAN**.

Configuration Address Source

This feature allows the user to select the source of the IP address for this computer. If Static is selected, you will need to know the IP address of this computer and enter it to the system manually in the field. If DHCP is selected, the BIOS will search for a DHCP (Dynamic Host Configuration Protocol) server in the network that is attached to and request the next available IP address for this computer. The options are **DHCP** and Static.

*If the item above is set to Static, the following items will become available for configuration:

Station IP Address

This item displays the Station IP address for this computer. This should be in decimal and in dotted quad form (i.e., 192.168.10.253).

Subnet Mask

This item displays the sub-network that this computer belongs to. The value of each three-digit number separated by dots should not exceed 255.

Station MAC Address

This item displays the Station MAC address for this computer. Mac addresses are 6 two-digit hexadecimal numbers.

Gateway IP Address

This item displays the Gateway IP address for this computer. This should be in decimal and in dotted quad form (i.e., 172.31.0.1).

VLAN

This item displays the virtual LAN settings. The options are **Disable** and Enable.

Configure IPV6 Support

This section displays configuration features for IPV6 support.

IPV6 address status

IPV6 Support

Use this feature to enable IPV6 support. The options are **Enabled** and Disabled.

Configuration Address Source

This feature allows the user to select the source of the IP address for this computer. If Static is selected, you will need to know the IP address of this computer and enter it to the system manually in the field. If DHCP is selected, the BIOS will search for a DHCP (Dynamic Host Configuration Protocol) server in the network that is attached to and request the next available IP address for this computer. The options are Static, and **DHCP**.

*If the item above is set to Static, the following items will become available for configuration:

- Station IPV6 Address
- Prefix Length
- IPV6 Router1 IP Address

4.6 Security

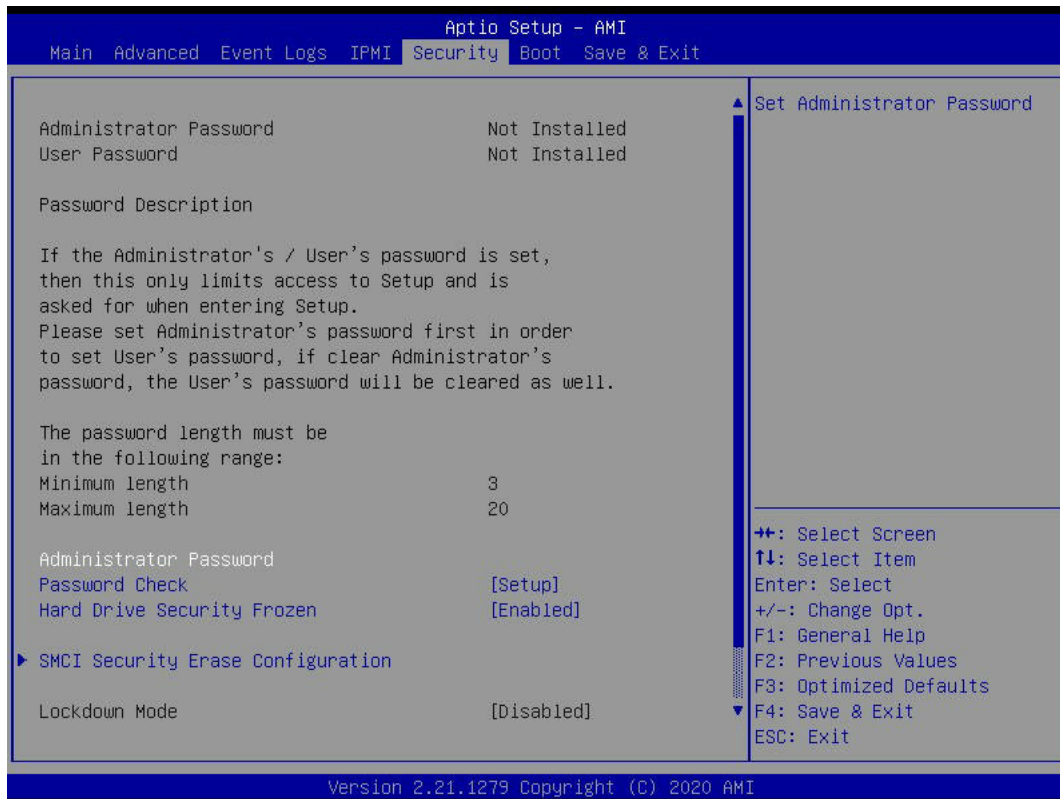

This menu allows the user to configure the following security settings for the system.

Administrator Password

This feature indicates if an administrator password has been installed. It also allows the user to set the administrator password which is required to enter the BIOS setup utility. The length of the password should be from 3 characters to 20 characters long.

User Password (Available when an Administrator Password is entered)

This feature indicates if a user's password has been installed. It also allows the user to set the user's password which is required to enter the BIOS setup utility. This feature provides the description of the user's password. The length of the password should be from 3 characters to 20 characters long.

Password Check

Select Setup for the system to check for a password at Setup. Select Always for the system to check for a password upon system boot and upon entering the BIOS Setup utility. The options are **Setup** and Always.

This feature sets the system boot order of detected devices.

- Boot Option #1

Hard Drive Security Frozen

Select Enabled to freeze the Lock Security feature for the HDDs to protect key data in hard drives from being altered. The options are **Enabled** and Disabled.

►SMCI Security Erase Configuration

This section allows the user to configure the SMCI-proprietary Security Erase settings. When this section is selected, the following features will display:

- HDD Name: This feature displays the name of the HDD/SATA drive that is connected to the SMCI Security Erase Configuration submenu.
- HDD Serial Number: This feature displays the serial number of the HDD/SATA device that is connected to the SMCI Security Erase Configuration submenu.
- Estimated Time: This feature displays the estimate time needed to perform the selected Security Erase features.
- HDD User Pwd (Password) Status: This feature indicates if a password has been set as a SATA user password which will allow the user to configure SMCI Security Erase settings on the HDD (SATA) device by using this SATA user password.

Security Function

Select Password to set an HDD/SATA password which will allow the user to configure the security settings of the HDD/SATA device. Select Security Erase - Password to enter a SATA user password to allow the user to erase the password and the contents previously stored in the HDD/SATA device. Select Security Erase - Without Password to use the manufacturer default password "11111111" as the SATA user password and allow the user to erase the contents of the HDD/SATA device by using this default password. The options are **Disabled**, Set Password, Security Erase-Password, and Security Erase-Without Password.

Password

Use this feature to set the SATA user password which will allow the user to configure the SMCI Security Erase settings by using the SATA user password.

Lockdown Mode

Select Enabled to support Lockdown Mode which will prevent existing data or keys stored in the system from being altered or changed in an effort to preserve system integrity and security. The options are Enabled and **Disabled**.

► Secure Boot



Note: For detailed instructions on how to configure Secure Boot settings, please refer to the Secure Boot Configuration User's Guide posted on the web page under the link: <http://www.supernmicro.com/support/manuals/>.

When you select this submenu and press the <Enter> key, the following items will display:

- Secure Mode
- Vendor Keys
- Secure Boot

Secure Boot

Select Enabled to use Secure Boot settings. The options are **Enabled** and Disabled.

Secure Boot Mode

Use this feature to select the desired secure boot mode for the system. The options are **Standard** and Custom.

CMS Support

If this feature is set to Enabled, legacy devices will be supported by the system. The options are **Enabled** and Disabled.

► Key Management (Available when "Secure Boot Mode" is set to Custom)

Vendor Keys

► Provision Factory Defaults

Select Enabled to install factory default Secure Boot keys after the platform reset while the system is in the Setup mode. The options are **Disabled** and Enabled.

► Restore Factory Keys

Select Yes to restore manufacturer default keys used to ensure system security. The options are **Yes** and No.

► Reset to Setup Mode

This feature resets the system to Setup Mode.

▶Export Secure Boot Variables

This feature exports the NVRAM contents of Secure Boot variables to a storage device.

▶Enroll EFI Image

This feature specifies which EFI (Extensible Firmware Interface) image should be used for the system when it operates in the Secure Boot mode.

Device Guard Ready

▶Remove 'UEFI CA' from DB

Select Yes to remove UEFI CA from the database. The options are **Yes** and No.

▶Restore DB defaults

Select Yes to restore database variables to the manufacturer default settings. The options are **Yes** and No.

Secure Boot Variable/Size/Keys/Key Source

▶Platform Key (PK)

Use this feature to enter and configure a set of values to be used as platform firmware keys for the system. These values also indicate the sizes, keys numbers, and the sources of the authorized signatures. Select Update to update the platform key. The options are **Details**, Export, Update, and Delete.

▶Key Exchange Keys

Use this feature to enter and configure a set of values to be used as Key-Exchange-Keys for the system. These values also indicate the sizes, keys numbers, and the sources of the authorized signatures. Select Update to update your "Key Exchange Keys". Select Append to append your "Key Exchange Keys". The options are **Details**, Export, Update, Append, and Delete.

▶Authorized Signatures

Use this feature to enter and configure a set of values to be used as Authorized Signatures for the system. These values also indicate the sizes, keys numbers, and the sources of the authorized signatures. Select Update to update your "Authorized Signatures". Select Append to append your "Authorized Signatures". The options are **Details**, Export, Update, Append, and Delete.

▶Forbidden Signatures

Use this feature to enter and configure a set of values to be used as Forbidden Signatures for the system. These values also indicate sizes, keys numbers, and key sources of the forbidden signatures. Select Update to update your "Forbidden Signatures". Select Append to append your "Forbidden Signatures". The options are **Details**, Export, Update, Append, and Delete.

▶Authorized TimeStamps

This feature allows the user to set and save the timestamps for the authorized signatures which will indicate the time when these signatures are entered into the system. These values also indicate sizes, keys, and key sources of the authorized timestamps. Select Update to update your "Authorized TimeStamps". Select Append to append your "Authorized TimeStamps". The settings are **Update** and Append.

▶OsRecovery (OS Recovery) Signatures

This feature allows the user to set and save the authorized signatures used for OS recovery. Select Update to update your "OS Recovery Signatures". These values also indicate sizes, keys, and key sources of the OsRecovery signatures. Select Append to append your "OS Recovery Signatures". The settings are **Update** and Append.

4.7 Boot

Use this feature to configure Boot Settings:

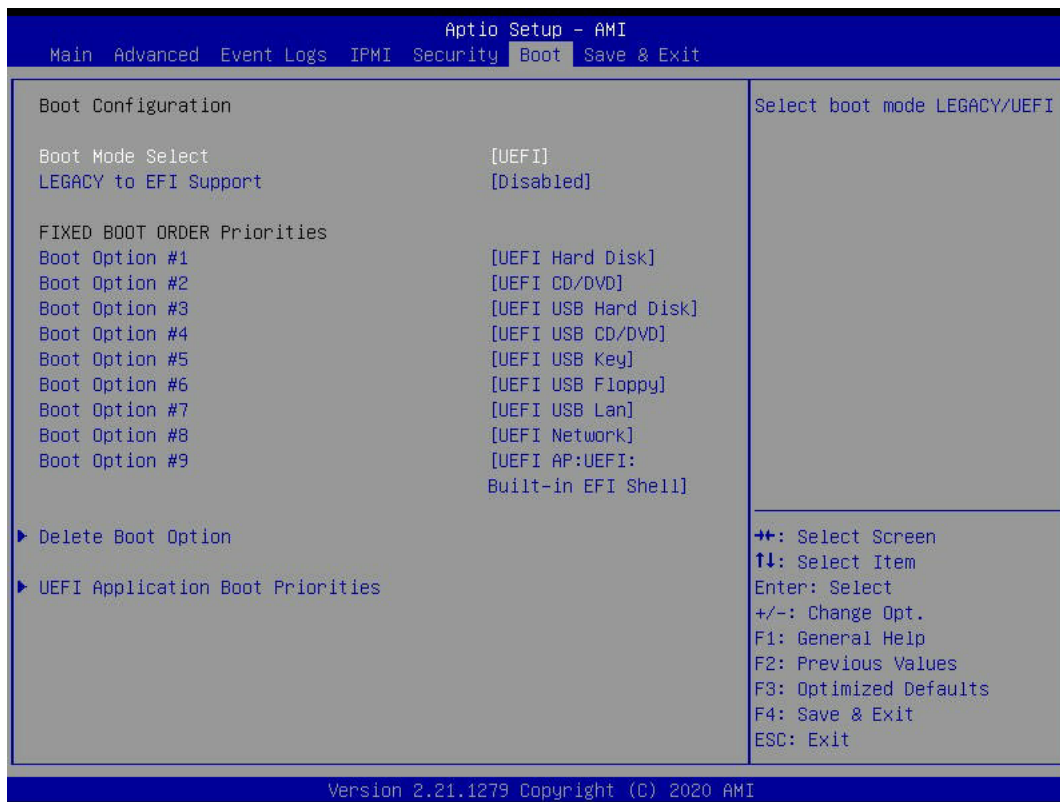

Boot Mode Select

Use this feature to select the type of devices from which the system will boot. The options are LEGACY, **UEFI (Unified Extensible Firmware Interface)**, and DUAL.

LEGACY to EFI Support

Select Enabled for the system to boot from an EFI OS when the Legacy OS fails. The options are Enabled and **Disabled**.

Fixed Boot Order Priorities

This feature prioritizes the order of a bootable device from which the system will boot. Press <Enter> on each item sequentially to select devices.

When the feature "Boot Mode Select" is set to **Dual** (default), the following items will be displayed for the user to configure the boot settings:

- Boot Option #1 ~ Boot Option #17

When the feature "Boot Mode Select" is set to Legacy, the following items will be displayed for configuration:

- Boot Option #1 ~ Boot Option #8

When the feature "Boot Mode Select" is set to UEFI, the following items will be displayed for configuration:

- Boot Option #1 ~ Boot Option #9

▶ Delete Boot Option

This feature allows the user to select a boot device to delete from the boot priority list.

Delete Boot Option

This feature allows the user to remove an EFI boot option from the boot priority list.

▶ UEFI Application Boot Priorities

Boot Option #1

4.8 Save & Exit

Select the Save & Exit menu from the BIOS setup screen to configure the settings below.

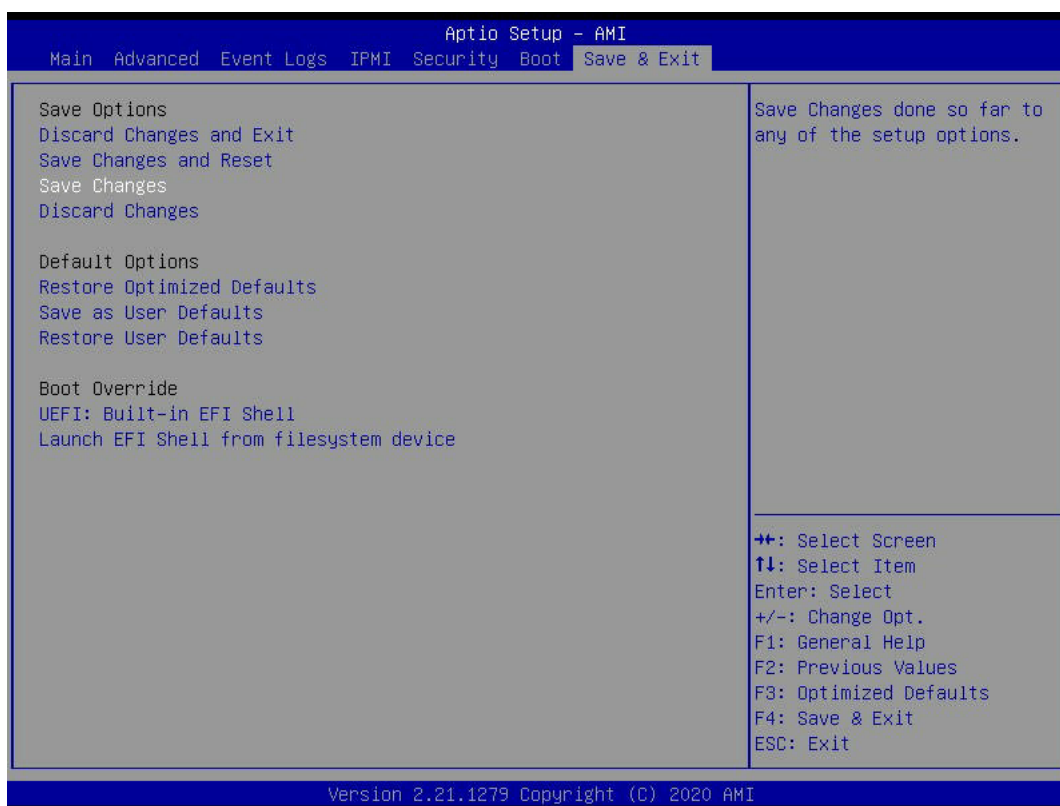

Save Options

Discard Changes and Exit

Select this option to exit from the BIOS setup utility without making any permanent changes to the system configuration and reboot the computer.

Save Changes and Reset

When you have completed the system configuration changes, select this option to leave the BIOS setup utility and reboot the computer for the new system configuration parameters to become effective.

Save Changes

When you have completed the system configuration changes, select this option to save all changes you've made. This will not reset (reboot) the system.

Discard Changes

Select this option and press <Enter> to discard all the changes you've made and return to the AMI BIOS setup utility.

Default Options

Restore Default Values

To set this feature, select Restore Default Values from the Exit menu and press <Enter> to load manufacturer default settings which are intended for maximum system performance but not for maximum stability.

Save As User Defaults

To set this feature, select this feature and press <Enter> to save all changes on the default values entered by the user to the BIOS setup utility for future use.

Restore the User Default Values

To set this feature, select Restore the User Default Values from the Exit menu and press <Enter>. Use this feature to retrieve user-defined default settings that have been saved previously.

Boot Override

This feature allows the user to override the Boot priorities sequence in the Boot menu, and immediately boot the system with a device specified by the user instead of the one specified in the boot list. This is a one-time override.

Appendix A

BIOS POST Codes

A.1 BIOS POST Codes

The AMI BIOS supplies additional checkpoint codes, which are documented online at <http://www.supernmicro.com/support/manuals/> ("AMI BIOS POST Codes User's Guide").

When BIOS performs the Power On Self Test, it writes checkpoint codes to I/O port 0080h. If the computer cannot complete the boot process, a diagnostic card can be attached to the computer to read I/O port 0080h (Supernmicro p/n AOC-LPC80-20).

For information on AMI updates, please refer to <http://www.ami.com/products/>.

Appendix B

Software

After the hardware has been installed, you can install the Operating System (OS), configure RAID settings, and install the drivers.

B.1 Microsoft Windows OS Installation

If you will be using RAID, you must configure RAID settings before installing the Windows OS and the RAID driver. Refer to the RAID Configuration User Guides posted on our website at www.supernmicro.com/support/manuals.

Installing the OS

1. Create a method to access the MS Windows installation ISO file. That might be a DVD, perhaps using an external USB/SATA DVD drive, or a USB flash drive, or the BMC KVM console.
2. Retrieve the proper RST/RSTe driver. Go to the Supermicro web page for your motherboard and click on "Download the Latest Drivers and Utilities", select the proper driver, and copy it to a USB flash drive.
3. Boot from a bootable device with Windows OS installation. You can see a bootable device list by pressing **F11** during the system startup.

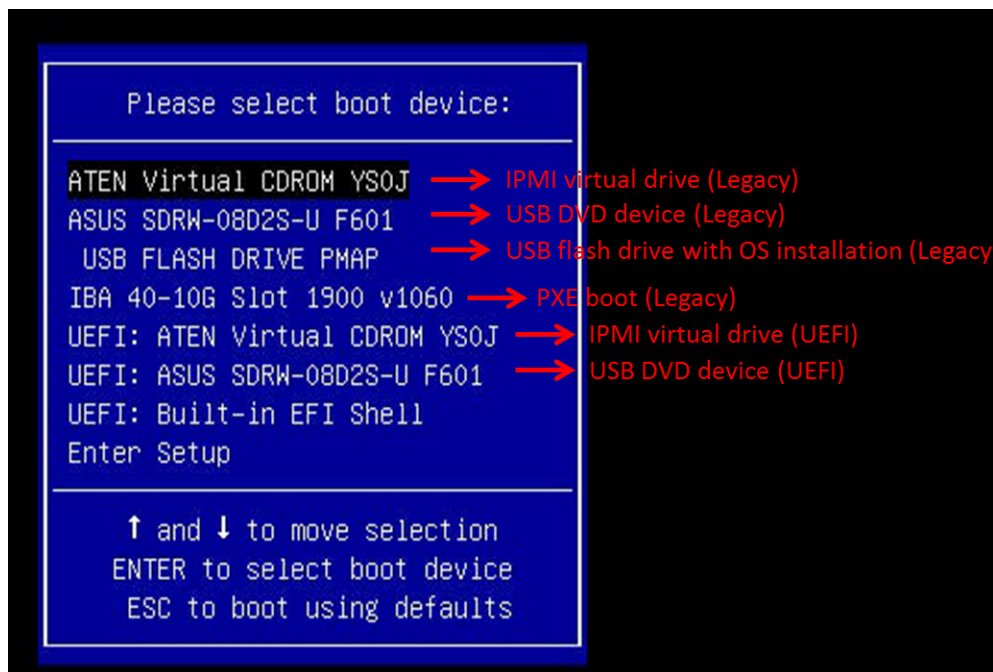

4. During Windows Setup, continue to the dialog where you select the drives on which to install Windows. If the disk you want to use is not listed, click on “Load driver” link at the bottom left corner.

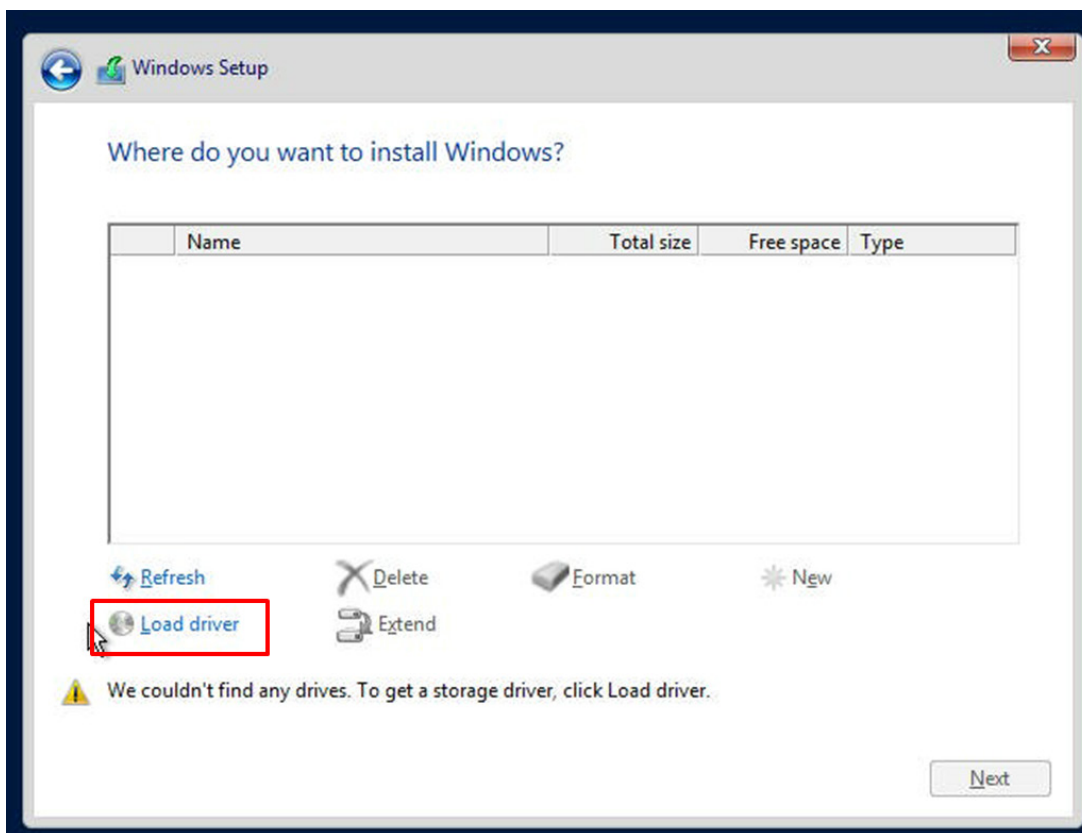

To load the driver, browse the USB flash drive for the proper driver files.

- For RAID, choose the SATA/sSATA RAID driver indicated then choose the storage drive on which you want to install it.
 - For non-RAID, choose the SATA/sSATA AHCI driver indicated then choose the storage drive on which you want to install it.
5. Once all devices are specified, continue with the installation.
 6. After the Windows OS installation has completed, the system will automatically reboot multiple times.

B.2 Driver Installation

The Supermicro website contains drivers and utilities for your system at <https://www.supermicro.com/wdl/driver>. Some of these must be installed, such as the chipset driver.

After accessing the website, go into the CDR_Images (in the parent directory of the above link) and locate the ISO file for your motherboard. Download this file to a USB flash drive or a DVD. (You may also use a utility to extract the ISO file if preferred.)

Another option is to go to the Supermicro website at <http://www.supermicro.com/products/>. Find the product page for your motherboard, and "Download the Latest Drivers and Utilities".

Insert the flash drive or disk and the screenshot shown below should appear.

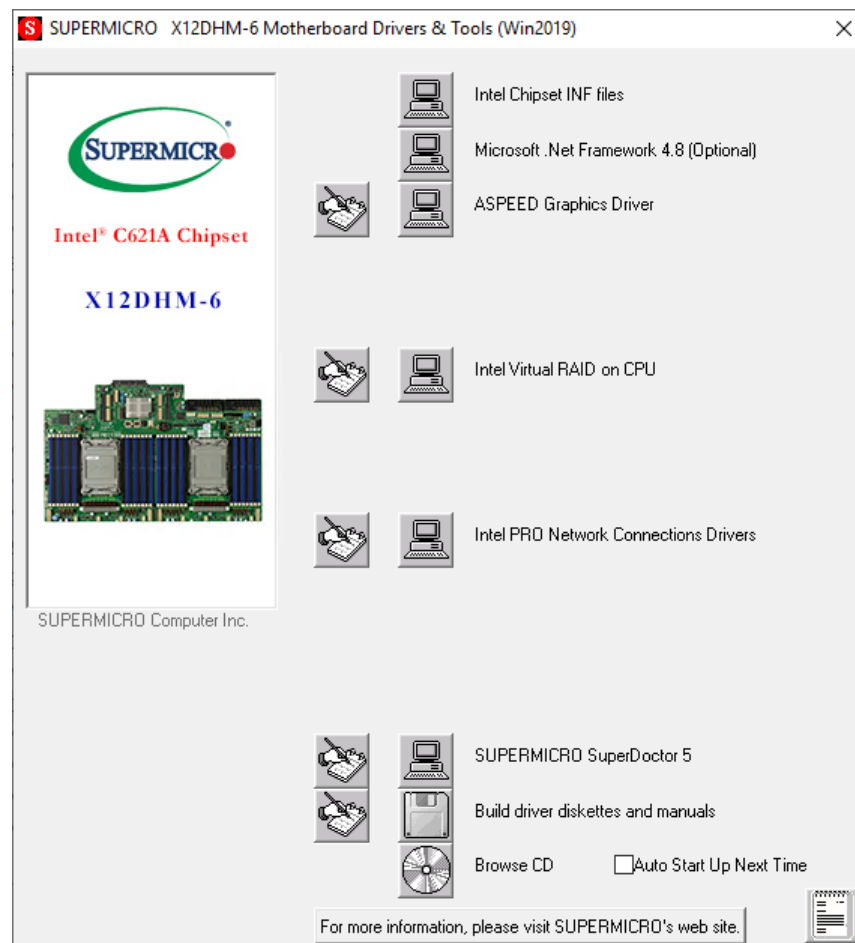

Note: Click the icons showing a hand writing on paper to view the readme files for each item. Click the computer icons to the right of these items to install each item (from top to the bottom) one at a time. **After installing each item, you must reboot the system before moving on to the next item on the list.** The bottom icon with a CD on it allows you to view the entire contents.

B.3 SuperDoctor® 5

The Supermicro SuperDoctor 5 is a program that functions in a command-line or web-based interface for Windows and Linux operating systems. The program monitors such system health information as CPU temperature, system voltages, system power consumption, fan speed, and provides alerts via email or Simple Network Management Protocol (SNMP).

SuperDoctor 5 comes in local and remote management versions and can be used with Nagios to maximize your system monitoring needs. With SuperDoctor 5 Management Server (SSM Server), you can remotely control power on/off and reset chassis intrusion for multiple systems with SuperDoctor 5 or BMC. SuperDoctor 5 Management Server monitors HTTP, FTP, and SMTP services to optimize the efficiency of your operation.

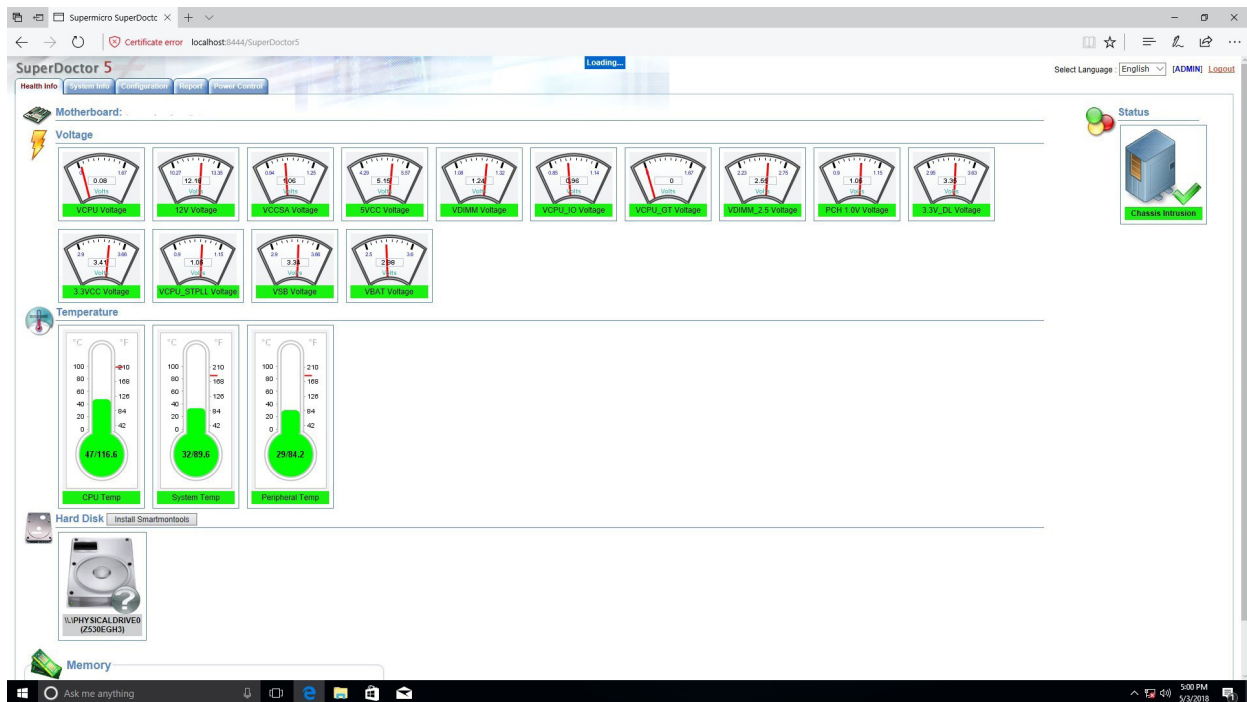

B.4 BMC

The X12DHM-6 supports the Intelligent Platform Management Interface (BMC). BMC is used to provide remote access, monitoring and management. There are several BIOS settings that are related to BMC.

For general documentation and information on BMC, please visit our website at: <http://www.supermicro.com/products/nfo/BMC.cfm>.

B.5 Logging into the BMC (Baseboard Management Controller)

Supermicro ships standard products with a unique password for the BMC ADMIN user. This password can be found on a label on the motherboard.

When logging in to the BMC for the first time, please use the unique password provided by Supermicro to log in. You can change the unique password to a user name and password of your choice for subsequent logins.

For more information regarding BMC passwords, please visit our website at <http://www.supermicro.com/bmcpassword>.

Appendix C

Standardized Warning Statements

The following statements are industry standard warnings, provided to warn the user of situations which have the potential for bodily injury. Should you have questions or experience difficulty, contact Supermicro's Technical Support department for assistance. Only certified technicians should attempt to install or configure components.

Read this section in its entirety before installing or configuring components.

These warnings may also be found on our website at http://www.supermicro.com/about/policies/safety_information.cfm.

Battery Handling



Warning! There is the danger of explosion if the battery is replaced incorrectly. Replace the battery only with the same or equivalent type recommended by the manufacturer. Dispose of used batteries according to the manufacturer's instructions

電池の取り扱い

電池交換が正しく行われなかった場合、破裂の危険性があります。交換する電池はメーカーが推奨する型、または同等のものを使用下さい。使用済電池は製造元の指示に従って処分して下さい。

警告

電池更換不當會有爆炸危險。請只使用同類電池或製造商推薦的功能相當的電池更換原有電池。請按製造商的說明處理廢舊電池。

警告

電池更換不當會有爆炸危險。請使用製造商建議之相同或功能相當的電池更換原有電池。請按照製造商的說明指示處理廢棄舊電池。

Warnung

Bei Einsetzen einer falschen Batterie besteht Explosionsgefahr. Ersetzen Sie die Batterie nur durch den gleichen oder vom Hersteller empfohlenen Batterietyp. Entsorgen Sie die benutzten Batterien nach den Anweisungen des Herstellers.

Attention

Danger d'explosion si la pile n'est pas remplacée correctement. Ne la remplacer que par une pile de type semblable ou équivalent, recommandée par le fabricant. Jeter les piles usagées conformément aux instructions du fabricant.

¡Advertencia!

Existe peligro de explosión si la batería se reemplaza de manera incorrecta. Reemplazar la batería exclusivamente con el mismo tipo o el equivalente recomendado por el fabricante. Desechar las baterías gastadas según las instrucciones del fabricante.

אזהרה!

קיימת סכנת פיצוץ של הסוללה במידה והוחלפה בדרך לא תקינה. יש להחליף את הסוללה בסוג התואם מחברת יצרן מומלצת. סילוק הסוללות המשומשות יש לבצע לפי הוראות היצרן.

هناك خطر من انفجار في حالة اسبدال البطارية بطريقة غير صحيحة فعلي
اسبدال البطارية فقط بنفس النوع أو ما يعادلها مما أوصت به الشركة المصنعة
جخلص من البطاريات المسحمة وفقا لعمليات الشركة الصانعة

경고!

배터리가 올바르게 교체되지 않으면 폭발의 위험이 있습니다. 기존 배터리와 동일하거나 제조사에서 권장하는 동등한 종류의 배터리로만 교체해야 합니다. 제조사의 안내에 따라 사용된 배터리를 처리하여 주십시오.

Waarschuwing

Er is ontploffingsgevaar indien de batterij verkeerd vervangen wordt. Vervang de batterij slechts met hetzelfde of een equivalent type die door de fabrikant aanbevolen wordt. Gebruikte batterijen dienen overeenkomstig fabrieksvoorschriften afgevoerd te worden.

Product Disposal



Warning! Ultimate disposal of this product should be handled according to all national laws and regulations.

製品の廃棄

この製品を廃棄処分する場合、国の関係する全ての法律・条例に従い処理する必要があります。

警告

本产品的废弃处理应根据所有国家的法律和规章进行。

警告

本產品的廢棄處理應根據所有國家的法律和規章進行。

Warnung

Die Entsorgung dieses Produkts sollte gemäß allen Bestimmungen und Gesetzen des Landes erfolgen.

¡Advertencia!

Al deshacerse por completo de este producto debe seguir todas las leyes y reglamentos nacionales.

Attention

La mise au rebut ou le recyclage de ce produit sont généralement soumis à des lois et/ou directives de respect de l'environnement. Renseignez-vous auprès de l'organisme compétent.

סילוק המוצר

אזהרה!

סילוק סופי של מוצר זה חייב להיות בהתאם להנחיות וחוקי המדינה.

عند التخلص النهائي من هذا المنتج ينبغي التعامل معه وفقا لجميع القوانين واللوائح الوطنية

경고!

이 제품은 해당 국가의 관련 법규 및 규정에 따라 폐기되어야 합니다.

Waarschuwing

De uiteindelijke verwijdering van dit product dient te geschieden in overeenstemming met alle nationale wetten en reglementen.