



M12SWA-TF

USER'S MANUAL

Revision 1.1b

The information in this User's Manual has been carefully reviewed and is believed to be accurate. The vendor assumes no responsibility for any inaccuracies that may be contained in this document, and makes no commitment to update or to keep current the information in this manual, or to notify any person or organization of the updates. **Please Note: For the most up-to-date version of this manual, please see our website at www.supermicro.com.**

Super Micro Computer, Inc. ("Supermicro") reserves the right to make changes to the product described in this manual at any time and without notice. This product, including software and documentation, is the property of Supermicro and/or its licensors, and is supplied only under a license. Any use or reproduction of this product is not allowed, except as expressly permitted by the terms of said license.

IN NO EVENT WILL Super Micro Computer, Inc. BE LIABLE FOR DIRECT, INDIRECT, SPECIAL, INCIDENTAL, SPECULATIVE OR CONSEQUENTIAL DAMAGES ARISING FROM THE USE OR INABILITY TO USE THIS PRODUCT OR DOCUMENTATION, EVEN IF ADVISED OF THE POSSIBILITY OF SUCH DAMAGES. IN PARTICULAR, SUPER MICRO COMPUTER, INC. SHALL NOT HAVE LIABILITY FOR ANY HARDWARE, SOFTWARE, OR DATA STORED OR USED WITH THE PRODUCT, INCLUDING THE COSTS OF REPAIRING, REPLACING, INTEGRATING, INSTALLING OR RECOVERING SUCH HARDWARE, SOFTWARE, OR DATA.

Any disputes arising between manufacturer and customer shall be governed by the laws of Santa Clara County in the State of California, USA. The State of California, County of Santa Clara shall be the exclusive venue for the resolution of any such disputes. Supermicro's total liability for all claims will not exceed the price paid for the hardware product.

FCC Statement: This equipment has been tested and found to comply with the limits for a Class A or Class B digital device pursuant to Part 15 of the FCC Rules. These limits are designed to provide reasonable protection against harmful interference when the equipment is operated in industrial environment for Class A device or in residential environment for Class B device. This equipment generates, uses, and can radiate radio frequency energy and, if not installed and used in accordance with the manufacturer's instruction manual, may cause harmful interference with radio communications. Operation of this equipment in a residential area is likely to cause harmful interference, in which case you will be required to correct the interference at your own expense.

California Best Management Practices Regulations for Perchlorate Materials: This Perchlorate warning applies only to products containing CR (Manganese Dioxide) Lithium coin cells. "Perchlorate Material-special handling may apply. See www.dtsc.ca.gov/hazardouswaste/perchlorate".



WARNING: This product can expose you to chemicals including lead, known to the State of California to cause cancer and birth defects or other reproductive harm. For more information, go to www.P65Warnings.ca.gov.

The products sold by Supermicro are not intended for and will not be used in life support systems, medical equipment, nuclear facilities or systems, aircraft, aircraft devices, aircraft/emergency communication devices or other critical systems whose failure to perform be reasonably expected to result in significant injury or loss of life or catastrophic property damage. Accordingly, Supermicro disclaims any and all liability, and should buyer use or sell such products for use in such ultra-hazardous applications, it does so entirely at its own risk. Furthermore, buyer agrees to fully indemnify, defend and hold Supermicro harmless for and against any and all claims, demands, actions, litigation, and proceedings of any kind arising out of or related to such ultra-hazardous use or sale.

Manual Revision 1.1b

Release Date: December 30, 2022

Unless you request and receive written permission from Super Micro Computer, Inc., you may not copy any part of this document. Information in this document is subject to change without notice. Other products and companies referred to herein are trademarks or registered trademarks of their respective companies or mark holders.

Copyright © 2022 by Super Micro Computer, Inc.
All rights reserved.

Printed in the United States of America

Preface

About This Manual

This manual is written for system integrators, IT technicians and knowledgeable end users. It provides information for the installation and use of the M12SWA-TF motherboard.

About This Motherboard

Built upon the functionality and capability of the AMD Ryzen™ Threadripper™ PRO 3000 and 5000 Series processors, the M12SWA-TF motherboard provides superior graphics capability and system performance while consuming little power. Please note that this motherboard is intended to be installed and serviced by professional technicians only. For processor/memory updates, please refer to our website at <http://www.supermicro.com/products/>.

Conventions Used in the Manual

Special attention should be given to the following symbols for proper installation and to prevent damage done to the components or injury to yourself:



Warning! Indicates important information given to prevent equipment/property damage or personal injury.



Warning! Indicates high voltage may be encountered when performing a procedure.

Contacting Supermicro

Headquarters

Address: Super Micro Computer, Inc.
980 Rock Ave.
San Jose, CA 95131 U.S.A.

Tel: +1 (408) 503-8000

Fax: +1 (408) 503-8008

Email: marketing@supermicro.com (General Information)
Sales-USA@supermicro.com (Sales Inquiries)
Government_Sales-USA@supermicro.com (Gov. Sales Inquiries)
support@supermicro.com (Technical Support)
RMA@supermicro.com (RMA Support)
Webmaster@supermicro.com (Webmaster)

Website: www.supermicro.com

Europe

Address: Super Micro Computer B.V.
Het Sterrenbeeld 28, 5215 ML
's-Hertogenbosch, The Netherlands

Tel: +31 (0) 73-6400390

Fax: +31 (0) 73-6416525

Email: Sales_Europe@supermicro.com (Sales Inquiries)
Support_Europe@supermicro.com (Technical Support)
RMA_Europe@supermicro.com (RMA Support)

Website: www.supermicro.nl

Asia-Pacific

Address: Super Micro Computer, Inc.
3F, No. 150, Jian 1st Rd.
Zhonghe Dist., New Taipei City 235
Taiwan (R.O.C)

Tel: +886-(2) 8226-3990

Fax: +886-(2) 8226-3992

Email: Sales-Asia@supermicro.com.tw (Sales Inquiries)
Support@supermicro.com.tw (Technical Support)
RMA@supermicro.com.tw (RMA Support)

Website: www.supermicro.com.tw

Table of Contents

Contacting Supermicro.....	4
Chapter 1 Introduction	
1.1 Quick Reference.....	11
Quick Reference Table.....	12
Motherboard Features.....	14
1.2 Processor and Chipset Overview.....	17
1.3 Special Features	17
Recovery from AC Power Loss.....	17
1.4 System Health Monitoring.....	18
Onboard Voltage Monitors	18
Fan Status Monitor with Firmware Control	18
Environmental Temperature Control	18
System Resource Alert.....	18
1.5 ACPI Features.....	19
1.6 Power Supply	19
1.7 Super I/O	19
Chapter 2 Installation	
2.1 Static-Sensitive Devices.....	20
Precautions	20
Unpacking	20
2.2 Motherboard Installation.....	21
Location of Mounting Holes	21
Installing the Motherboard.....	23
2.3 Processor and Heatsink Installation.....	24
2.4 Memory Support and Installation	32
Memory Support.....	32
DIMM Module Population Sequence	32
DIMM Installation	34
DIMM Removal	34
2.6 Rear I/O Ports	35
2.7 Front Control Panel.....	38

2.8 Connectors	39
2.9 Jumper Settings	45
How Jumpers Work.....	45
2.10 LED Indicators.....	48
Chapter 3 Troubleshooting	
3.1 Troubleshooting Procedures	49
Before Power On	49
No Power	49
No Video	50
System Boot Failure.....	50
Memory Errors	50
What to do if the System is Losing the Setup Configuration.....	50
When the System Becomes Unstable	51
3.2 Technical Support Procedures	52
3.3 Frequently Asked Questions	53
3.4 Returning Merchandise for Service.....	54
3.5 Battery Removal and Installation	54
Battery Removal.....	54
Proper Battery Disposal	54
Battery Installation.....	55
Chapter 4 UEFI BIOS	
4.1 Introduction.....	56
Starting the Setup Utility	56
4.2 Main Setup	57
4.3 Advanced.....	59
4.4 IPMI	81
4.5 Event Logs	83
4.6 Security Settings	85
4.7 Boot Settings.....	88
4.8 Save & Exit.....	90
Appendix A Software	
A.1 Microsoft Windows OS Installation.....	92
A.2 Red Hat Linux OS Installation.....	93

A.3 Driver Installation.....	97
A.4 SuperDoctor® 5.....	98
A.5 IPMI	98
<i>Appendix B Standardized Warning Statements</i>	
B.1 Battery Handling.....	99
B.2 Product Disposal	101
<i>Appendix C UEFI BIOS Recovery</i>	
C.1 Overview.....	102
C.2 Recovering the UEFI BIOS Image.....	102
C.3 Recovering the BIOS Block with a USB Device	102
<i>Appendix D RAID Arrays</i>	
D.1 Enabling RAID Mode	105
D.2 Creating RAID Arrays	108
D.3 Deleting RAID Arrays	110

Chapter 1

Introduction

Congratulations on purchasing your computer motherboard from an industry leader. Supermicro boards are designed to provide you with the highest standards in quality and performance. In addition to the motherboard, several important parts that are included with the system are listed below. If anything listed is damaged or missing, please contact your retailer.

Important Links

For your system to work properly, please follow the links below to download all necessary drivers/utilities and the user's manual for your server.

- Supermicro product manuals: <http://www.supermicro.com/support/manuals/>
- Product drivers and utilities: <https://www.supermicro.com/wdl/>
- Product safety info: http://www.supermicro.com/about/policies/safety_information.cfm
- A secure data deletion tool designed to fully erase all data from storage devices can be found at our website: https://www.supermicro.com/about/policies/disclaimer.cfm?url=/wdl/utility/Lot9_Secure_Data_Deletion_Utility
- If you have any questions, please contact our support team at: support@supermicro.com

This manual may be periodically updated without notice. Please check the Supermicro website for possible updates to the manual revision level.

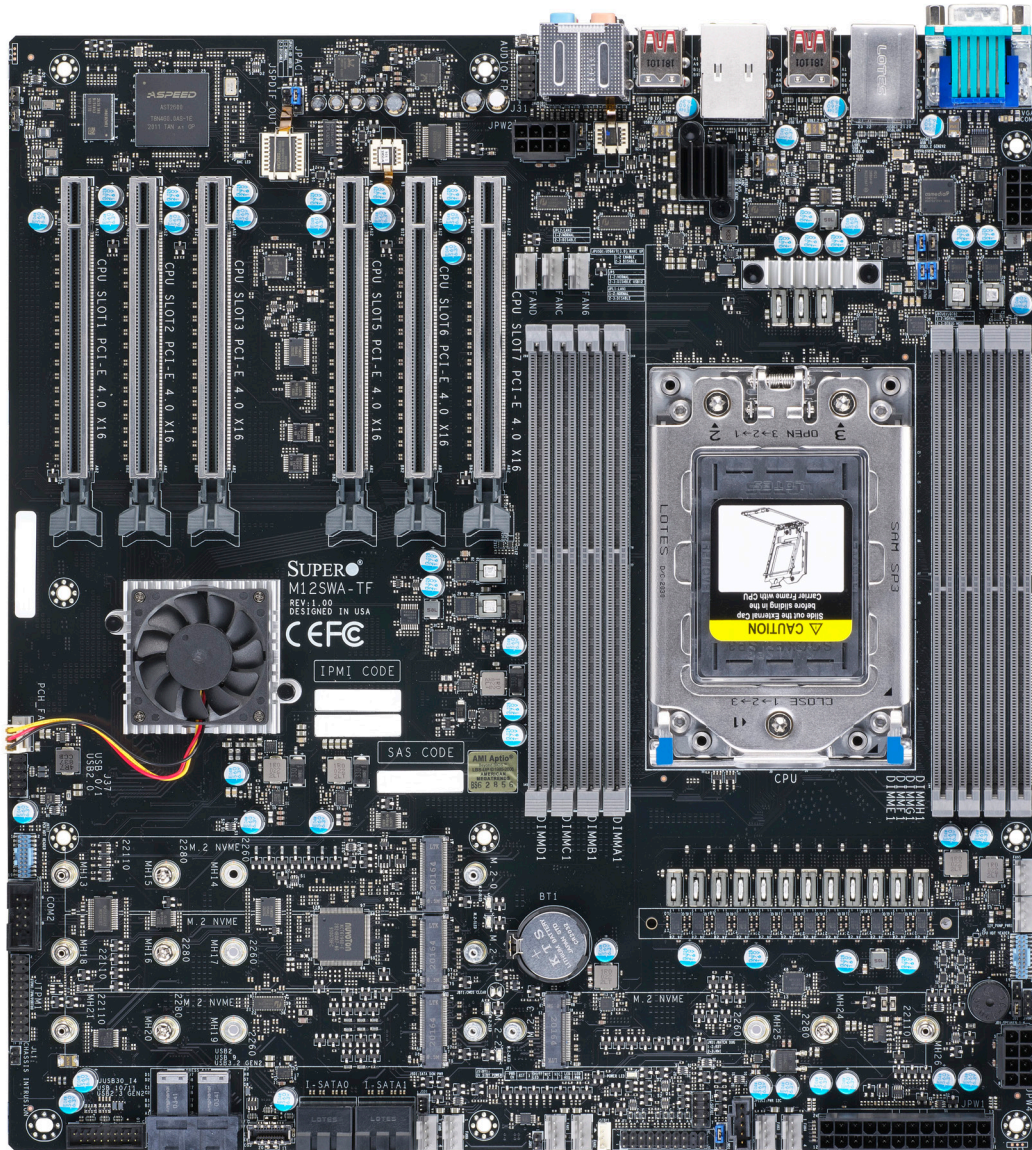

Figure 1-1. M12SWA-TF Motherboard Image

Note: All graphics shown in this manual were based upon the latest PCB revision available at the time of publication of the manual. The motherboard you received may or may not look exactly the same as the graphics shown in this manual.

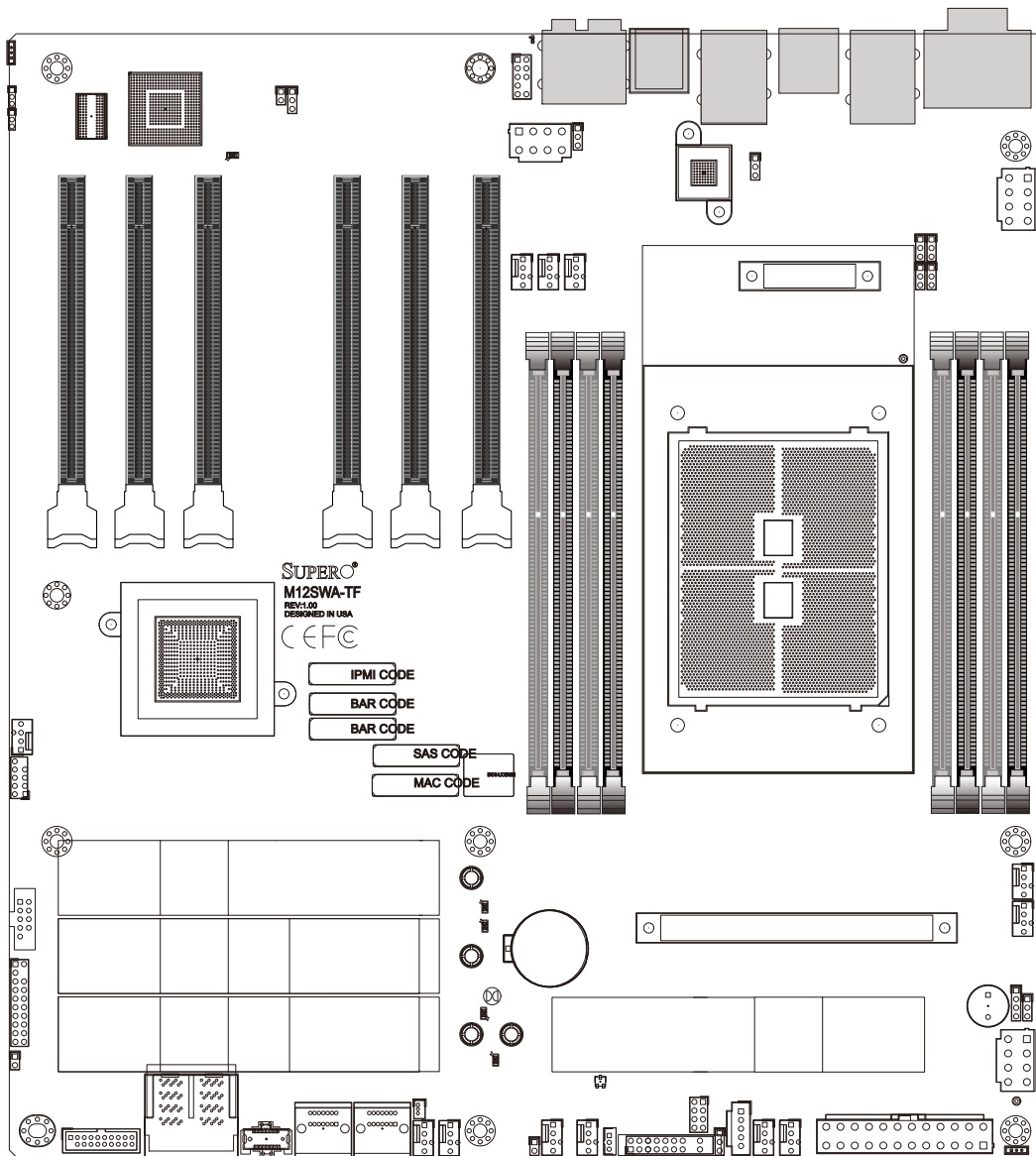
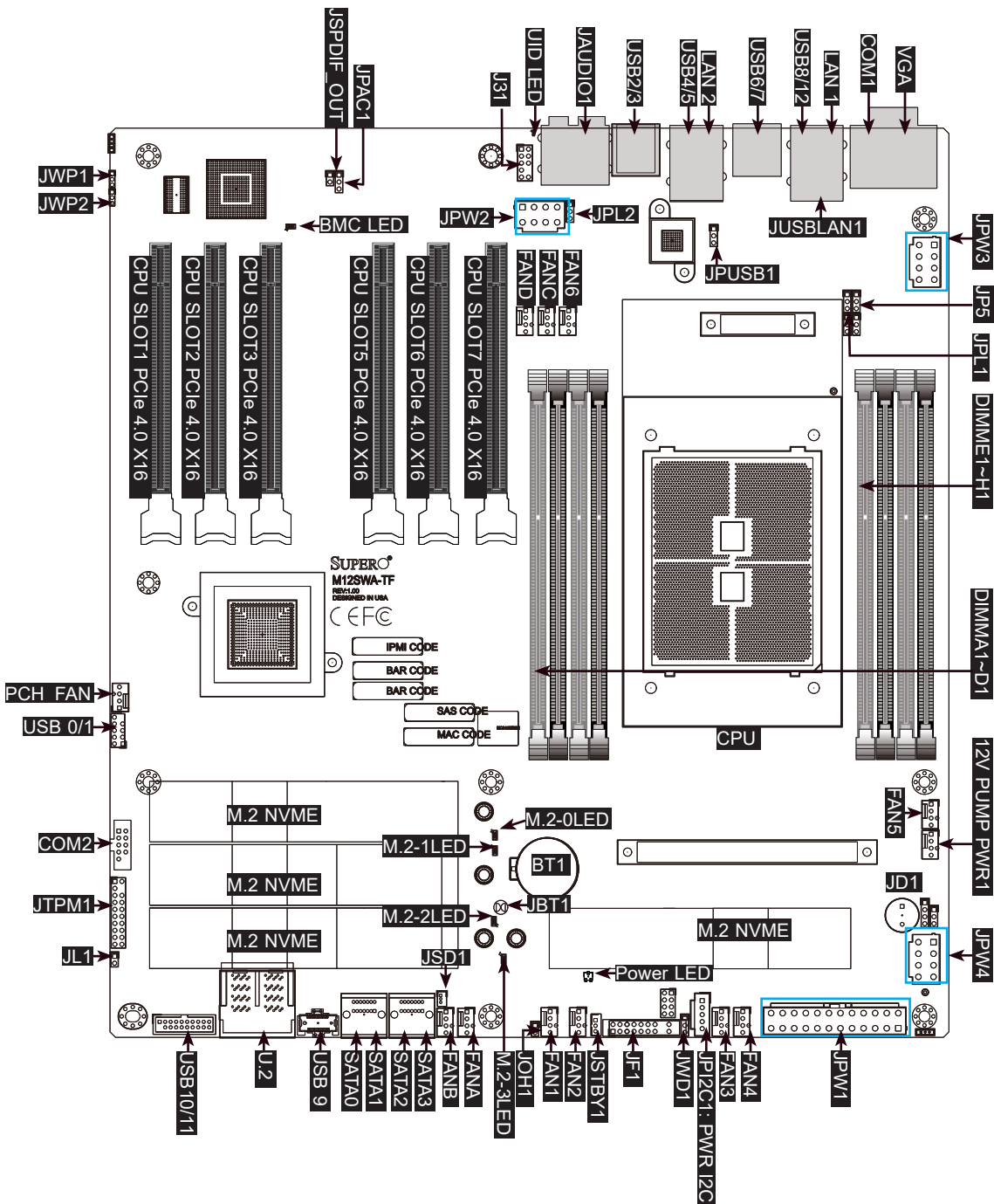

Figure 1-2. M12SWA-TF Motherboard Layout

Note: Components not documented are for internal testing only.

1.1 Quick Reference



Notes:

- See Chapter 2 for detailed information on jumpers, I/O ports, and JF1 front panel connections.
- Use only the correct type of onboard CMOS battery as specified by the manufacturer. Do not install the onboard battery upside down to avoid possible explosion.

Quick Reference Table

Jumper	Description	Default Setting
JBT1	Clear CMOS (Onboard)	Open (Normal)
JPAC1	HD Audio Enable/Disable	Pins 1-2 (Enabled)
JPL1, JPL2	LAN1/LAN2 Enable/Disable	Pins 1-2 (Enabled)
JPUSB1	USB6/7 Wake Up	Pins 1-2 (Enabled)
JWD1	Watch Dog Time Control	Pins 1-2 (Reset)
JP5	USB 12 Enable/Disable	Pins 1-2 (Enabled)

LED	Description	Status
M.2-0LED, M.2-1LED, M.2-2LED, M.2-3LED	M.2 LEDs for M.2-4/M.2-3/M.2-2/M.2-1	Green: Blinking: Device Working
BMC LED	BMC Heartbeat LED	Solid Green: BMC Normal
Power LED	Onboard Power LED	Blinking Green: Power On
UID-LED	Unit Identifier (UID) LED	Blue On: Unit Identified

Connector	Description
JD1	Front Panel External Speaker
J31	Front Panel Audio FP Header
BT1	Onboard Battery
COM1	COM Port (Back Panel)
CPU SLOT1~7	PCIe 4.0 x16 Slots
FAN1 ~ FAN6	CPU Fan Headers
FANA ~ FAND	System Fan Headers
12V_PUMP_PWR1	12V 4-pin Power Connector for Liquid Cooling CPU Pump
SATA0~3	Serial ATA (SATA 3.0) Ports (6Gb/second)
JSD1	SATA DOM Power Connector
JF1	Front Control Panel Header
JL1	Chassis Intrusion Header
JOH1	Overheat LED Header
JPI2C1	Power Supply SMBus I ² C Header
JPW1	24-pin ATX Main Power Connector (Required)
JPW2~JPW4	+12V 8-pin Power Connectors (Required)
JSTBY1	Standby Power Header (5V)

Note: The table above is continued on the next page.

Connector	Description
JTPM1	Trusted Platform Module (TPM)/Port 80 Header
JSPDIF In/JSPDIF Out	SPDIF (Sony/Philips Digital Interface) In/Out Headers
USB0/1	USB 2.0 Front Panel Header
USB10/11	USB 3.2 (Gen. 1) Type A Front Panel Header
U.2	Dual M.2 connectors that are SFF-8643 (minSAS HD) for U.2 drives only
USB9	USB 3.2 (Gen. 2) Type C Front Panel Header
VGA	VGA Port

Notes:

- Jumpers in the table not described are for manufacturing testing purposes only and are not covered in this manual.
- It is recommended that you connect both 8-pin (JPW3) and 24-pin (JPW1) connectors to your power supply modules before powering on the motherboard.
- For installing multiple GPU cards, it is required to connect both 8-pin connectors (JPW2 and JPW4). For details, see *2.8 Connectors*.

Motherboard Features

Motherboard Features

CPU

- AMD Ryzen™ Threadripper™ PRO 3000 and 5000 Series Processors in sWRX8/SP3 sockets

Memory

- Up to 8 DDR4 ECC/non-ECC UDIMM/ECC RDIMM sockets, with speeds of up to 3200MT/s (1DPC). Max capacity is up to 256GB (UDIMM)/2TB (RDIMM) in 8 DDR4 DIMM slots.

DIMM Size

- 8GB, 16GB, 32GB, 64GB, 128GB, 256GB at 1.2V

Chipset

- AMD WRX80

Expansion Slots

- Four M.2 PCIe 4.0 x4 Sockets (Supports M-Key 2260, 2280, and 22110; Software RAID 0,1,5,10; M.2 NVMe drives.)

Network

- 10G LAN: Single LAN via Marvell AQC113C 10Gb controller
- 1GbE LAN: Single LAN via Intel® i210AT controller (shared with IPMI)

Graphics

- ASPEED AST2600 BMC

I/O Devices

- One COM port connector on rear I/O panel
- One VGA connector on the rear I/O panel
- One TPM 2.0 header
- Four SATA 3.0 ports (SATA0~SATA3)
- One USB 3.2 Gen2x2 port (Type C, 20Gbps)
- Five USB 3.2 Gen2 ports (4 Type A, 1 front Intel Type C header, 10Gbps)
- Five USB 3.2 Gen1 ports (3 Type A, 1 via header)
- Two USB 2.0 via headers

Peripheral Devices

- Two USB 2.0 ports on the rear I/O panel (USB0/1)

BIOS

- AMI 256Mb Flash EEPROM
- ACPI 6.2, SMBIOS 3.1.1, Plug-and-Play (PnP), RTC (Real Time Clock) wakeup, Riser Card Auto-Detection support

Motherboard Features

Power Management

- ACPI power management (S3/S4/S5)
- Power button override mechanism
- Power-on mode for AC power recovery

System Health Monitoring

- Onboard voltage monitoring for +3.3V, +3.3V Standby, +5V, +5V Standby, +12V, VBAT, Vcore, Vsoc, and Memory
- Onboard temperature monitoring for CPU, System, and Memory
- CPU switching phase voltage regulator
- CPU Thermal Trip support
- CPU Thermal Design Power (TDP) support of up to 280W (See Note 1 at the bottom)

Fan Control

- Dual cooling zone
- Multi-speed fan control via onboard BMC
- Fan status monitoring via IPMI connection

System Management

- Trusted Platform Module (TPM) support
- System resource alert via SuperDoctor® 5
- Power Supply Monitoring
- SuperDoctor® 5, Watch Dog, NMI
- Chassis intrusion header and detection (JL1)
- SPM, SUM-InBand, SUM-OOB, IPMICFG, IPMIView, SMCIPMITOOL

LED Indicators

- Power State Indicator
- BMC Heartbeat Indicator

Dimensions

- 12" x 13" (30.48cm x 33.02cm)

Notes:

- The CPU maximum thermal design power (TDP) is subject to chassis and heatsink cooling restrictions. For proper thermal management, please check the chassis and heatsink specifications for proper CPU TDP sizing.
- If you purchase a Supermicro Out of Band (OOB) software license key (Supermicro P/N: SFT-OOB-LIC), please DO NOT change the IPMI MAC address.

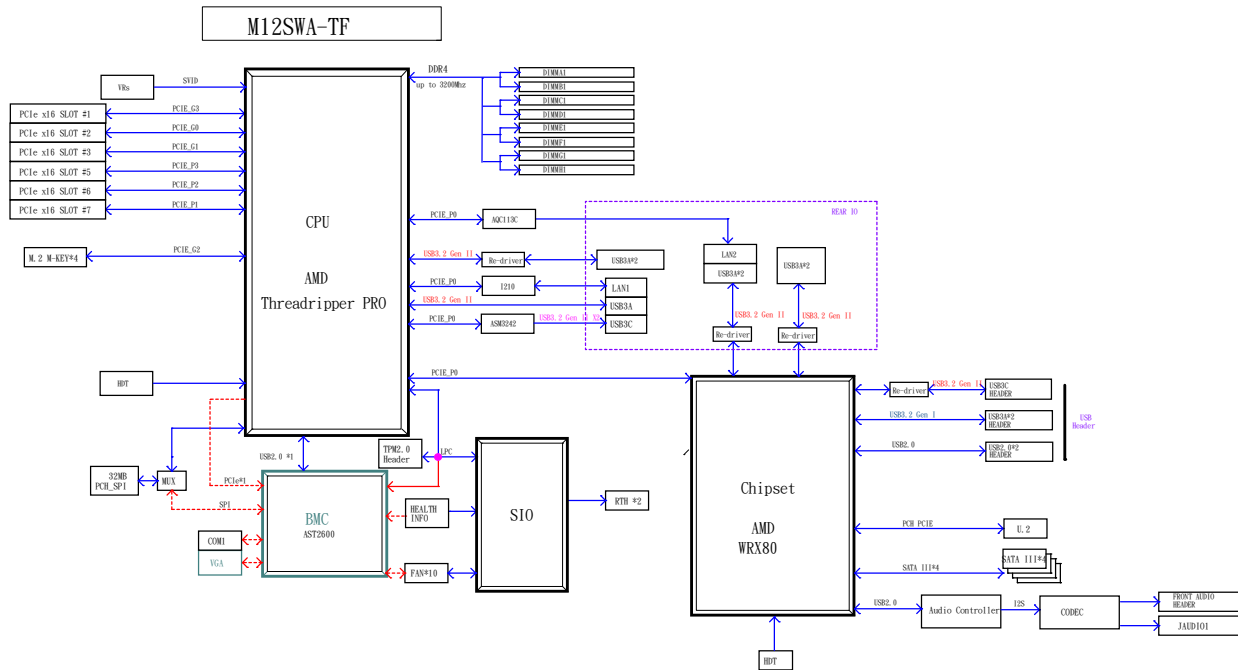

Figure 1-3. System Block Diagram

Note: This is a general block diagram and may not exactly represent the features on your motherboard. See the previous pages for the actual specifications of your motherboard.

1.2 Processor and Chipset Overview

Built upon the functionality and capability of the AMD Ryzen™ Threadripper™ PRO 3000 and 5000 Series Processors, up to 64 cores. The M12SWA-TF motherboard offers maximum I/O expendability, energy efficiency, and data reliability in a 7nm process architecture, and is optimized for embedded storage solutions, networking applications, or cloud-computing platforms.

With support of the new microarchitecture 7nm process technology, the M12SWA-TF drastically increases system performance for a multitude of workstation applications.

The AMD Ryzen™ Threadripper™ PRO 3000 and 5000 Series Processors support the following features:

- Leading single threaded and multithreaded performance
- AMD PRO Technologies
- Unrivaled memory bandwidth¹
- PCIe® 4.0 support for next-gen GPUs and storage
- BMC supports remote management, virtualization, and the security package for enterprise platforms.

1.3 Special Features

This section describes the health monitoring features of the M12SWA-TF motherboard. The motherboard has an onboard System Hardware Monitor chip that supports system health monitoring.

Recovery from AC Power Loss

The Basic I/O System (BIOS) provides a setting that determines how the system will respond when AC power is lost and then restored to the system. You can choose for the system to remain powered off (in which case you must press the power switch to turn it back on), or for it to automatically return to the power-on state. See the Advanced BIOS Setup section for this setting. The default setting is Last State.

1.4 System Health Monitoring

This section describes the health monitoring features of the M12SWA-TF motherboard. The motherboard has an onboard chip that supports system health monitoring. Once a voltage becomes unstable, a warning is given or an error message is sent to the screen. Users can adjust the voltage thresholds to define the sensitivity of the voltage monitor.

Onboard Voltage Monitors

The onboard voltage monitor will continuously scan crucial voltage levels. Once a voltage becomes unstable, it will give a warning or send an error message to the screen. Users can adjust the voltage thresholds to define the sensitivity of the voltage monitor. Real time readings of these voltage levels are all displayed in BMC.

Fan Status Monitor with Firmware Control

PC health monitoring in the BIOS can check the RPM status of the cooling fans. The onboard CPU and chassis fans are controlled by Thermal Management.

Environmental Temperature Control

The thermal control sensor monitors the CPU temperature in real time and will turn on the thermal control fan whenever the CPU temperature exceeds a user-defined threshold. The overheat circuitry runs independently from the CPU. Once the thermal sensor detects that the CPU temperature is too high, it will automatically turn on the thermal fans to prevent the CPU from overheating. The onboard chassis thermal circuitry can monitor the overall system temperature and alert the user when the chassis temperature is too high.

Note: To avoid possible system overheating, please be sure to provide adequate airflow to your system.

System Resource Alert

This feature is available when used with SuperDoctor 5[®]. SuperDoctor 5 is used to notify the user of certain system events. For example, you can configure SuperDoctor 5 to provide you with warnings when the system temperature, CPU temperatures, voltages and fan speeds go beyond a predefined range.

1.5 ACPI Features

ACPI stands for Advanced Configuration and Power Interface. The ACPI specification defines a flexible and abstract hardware interface that provides a standard way to integrate power management features throughout a computer system including its hardware, operating system and application software. This enables the system to automatically turn on and off peripherals such as network cards, hard disk drives and printers.

In addition to enabling operating system-directed power management, ACPI also provides a generic system event mechanism for Plug and Play and an operating system-independent interface for configuration control. ACPI leverages the Plug and Play BIOS data structures while providing a processor architecture-independent implementation that is compatible with Windows Server 2019 operating systems.

1.6 Power Supply

As with all computer products, a stable power source is necessary for proper and reliable operation. It is even more important for processors that have high CPU clock rates. In areas where noisy power transmission is present, you may choose to install a line filter to shield the computer from noise. It is recommended that you also install a power surge protector to help avoid problems caused by power surges.

1.7 Super I/O

The Super I/O (Aspeed AST2600 chip) includes a data separator, write pre-compensation circuitry, decode logic, data rate selection, a clock generator, drive interface control logic and interrupt and DMA logic. The wide range of functions integrated onto the Super I/O greatly reduces the number of components required for interfacing with floppy disk drives.

The Super I/O provides one high-speed, 16550 compatible serial communication port (UART), which supports serial infrared communication. This UART includes a 16-byte send/receive FIFO, a programmable baud rate generator, complete modem control capability and a processor interrupt system. This UART provides legacy speed with baud rate of up to 115.2 Kbps as well as an advanced speed with baud rates of 250 K, 500 K, or 1 Mb/s, which support higher speed modems.

The Super I/O provides functions that comply with ACPI (Advanced Configuration and Power Interface), which includes support of legacy and ACPI power management through a SMI or SCI function pin. It also features auto power management to reduce power consumption.

The IRQs, DMAs and I/O space resources of the Super I/O can be flexibly adjusted to meet ISA PnP requirements, which support ACPI and APM (Advanced Power Management).

Chapter 2

Installation

2.1 Static-Sensitive Devices

Electrostatic Discharge (ESD) can damage electronic components. To prevent damage to your motherboard, it is important to handle it very carefully. The following measures are generally sufficient to protect your equipment from ESD.

Precautions

- Use a grounded wrist strap designed to prevent static discharge.
- Touch a grounded metal object before removing the board from the antistatic bag.
- Handle the board by its edges only; do not touch its components, peripheral chips, memory modules or gold contacts.
- When handling chips or modules, avoid touching their pins.
- Put the motherboard and peripherals back into their antistatic bags when not in use.
- For grounding purposes, make sure that your chassis provides excellent conductivity between the power supply, the case, the mounting fasteners and the motherboard.
- Use only the correct type of CMOS onboard battery as specified by the manufacturer. Do not install the CMOS battery upside down, which may result in a possible explosion.

Unpacking

The motherboard is shipped in antistatic packaging to avoid static damage. When unpacking the motherboard, make sure that the person handling it is static protected.

2.2 Motherboard Installation

All motherboards have standard mounting holes to fit different types of chassis. Make sure that the locations of all the mounting holes for both the motherboard and the chassis match. Although a chassis may have both plastic and metal mounting fasteners, metal ones are highly recommended because they ground the motherboard to the chassis. Make sure that the metal standoffs click in or are screwed in tightly.

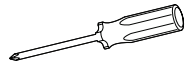

Phillips Screwdriver (1)



Phillips Screws (13)



Standoffs (13)
Only if Needed

Tools Needed

Location of Mounting Holes

Notes:

1. To avoid damaging the motherboard and its components, please do not use a force greater than 8 lb/inch on each mounting screw during motherboard installation.
2. Some components are very close to the mounting holes. Please take precautionary measures to avoid damaging these components when installing the motherboard to the chassis.

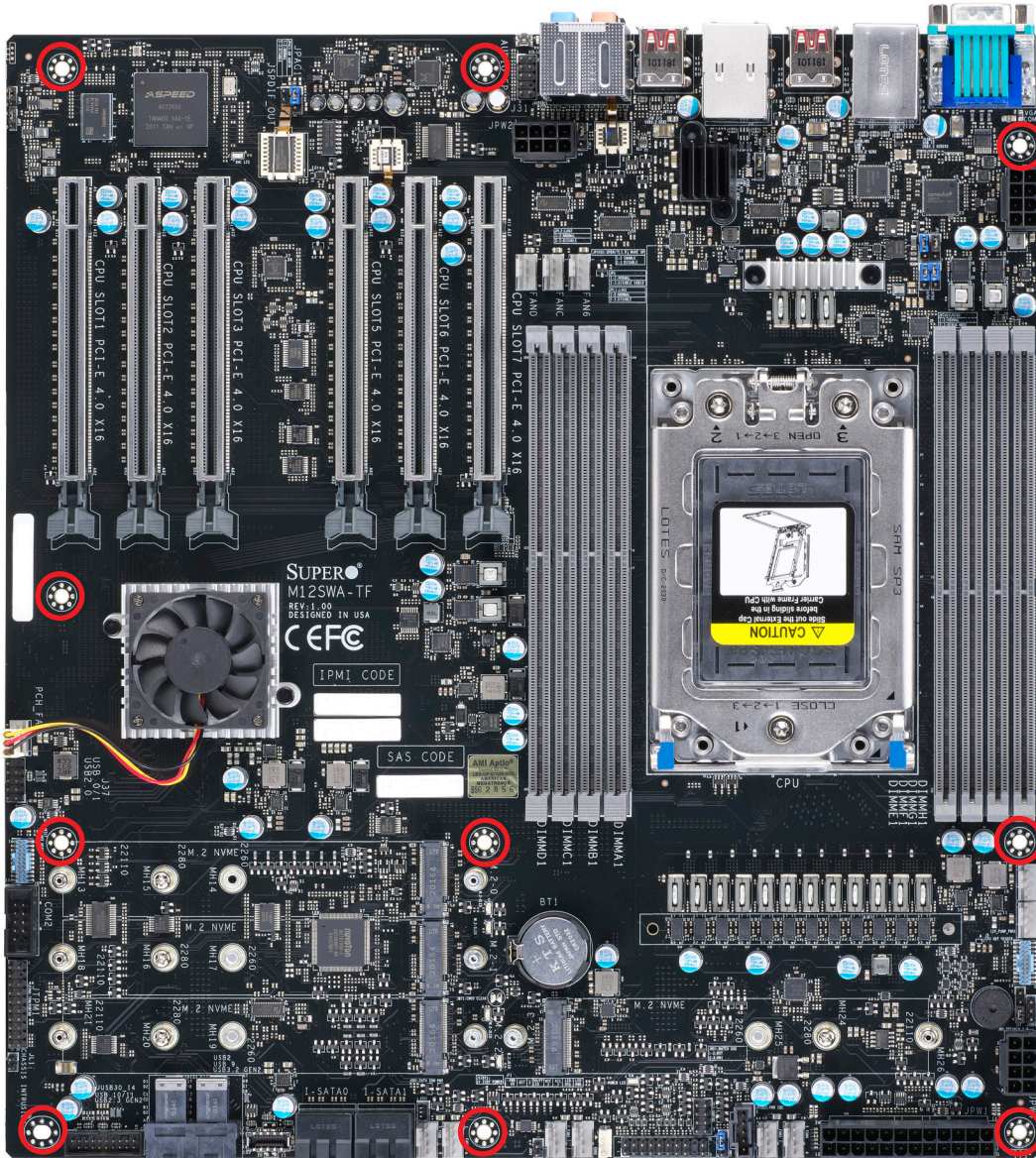
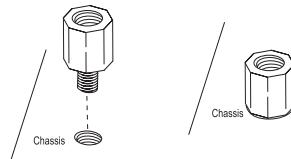

Figure 2-1. Motherboard Mounting Holes

Installing the Motherboard

Note: Always connect the power cord last, and always remove it before adding, removing, or changing any hardware components. Install the I/O shield into the chassis.

1. Locate the mounting holes on the motherboard. See the previous page for the location.
2. Locate the matching mounting holes on the chassis. Align the mounting holes on the motherboard against the mounting holes on the chassis.
3. Install standoffs in the chassis as needed.



4. Install the motherboard into the chassis carefully to avoid damaging other motherboard components.
5. Using the Phillips screwdriver, insert a Phillips head #6 screw into a mounting hole on the motherboard and its matching mounting hole on the chassis.

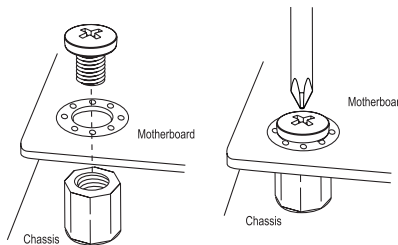

6. Repeat Step 5 to insert #6 screws into all mounting holes.
7. Make sure that the motherboard is securely placed in the chassis.

Note: Images displayed are for illustration only. Your chassis or components might look different from those shown in this manual.

2.3 Processor and Heatsink Installation

Warning: When handling the processor package, avoid placing direct pressure on the label area of the fan.

Important:

- For the Processor/Heatsink installation you need to use a T20 screwdriver when opening/closing the CPU socket.
- Always connect the power cord last, and always remove it before adding, removing or changing any hardware components. Make sure that you install the processor into the CPU socket before you install the CPU heatsink.
- If you buy a CPU separately, make sure that you use an AMD-certified multi-directional heatsink only.
- Make sure to install the motherboard into the chassis before you install the CPU heatsink.
- When receiving a motherboard without a processor pre-installed, make sure that the plastic CPU socket cap is in place and none of the socket pins are bent; otherwise, contact your retailer immediately.
- Refer to the Supermicro website for updates on CPU support.

Installing the Processor and Heatsink

1. Unscrew the screws holding down Force Frame in the sequence of 3-2-1. The screws are numbered on the Force Frame next to each screw hole.

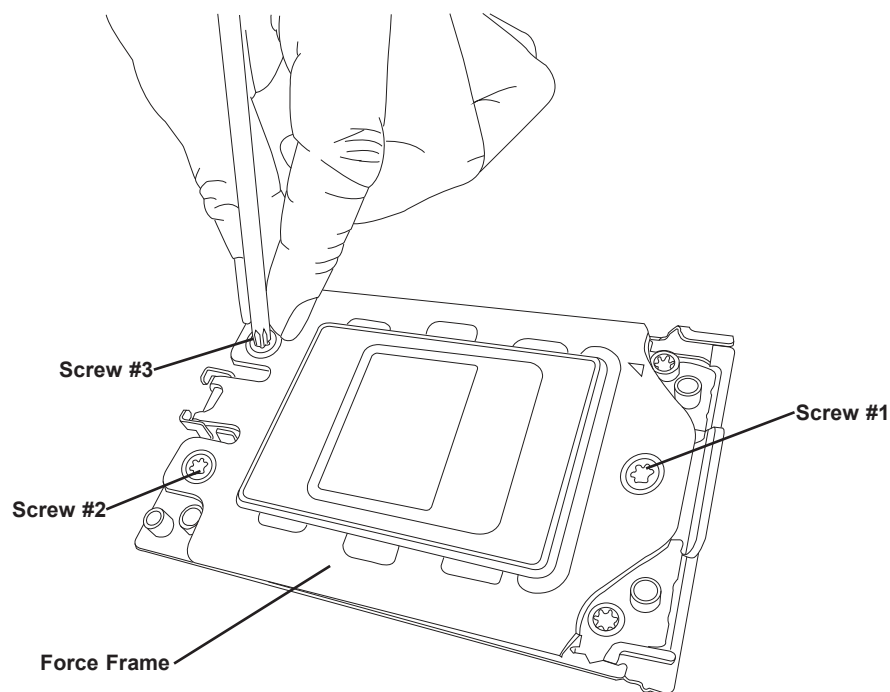

2. The spring-loaded Force Frame will raise up after the last screw securing it (#1) is removed. Gently allow it to lift up to its stopping position.

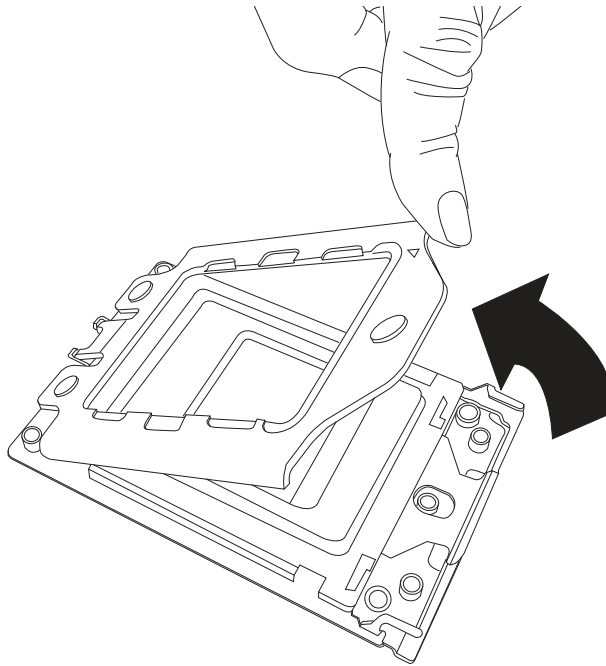

3. Lift the Rail Frame up by gripping the lift tabs near the front end of the rail frame. While keeping a secure grip of the Rail Frame, lift it to a position so you can do the next step of removing the External Cap.
4. **Note:** The Rail Frame is spring loaded, so keep a secure grip on it as you lift it so it does not snap up.

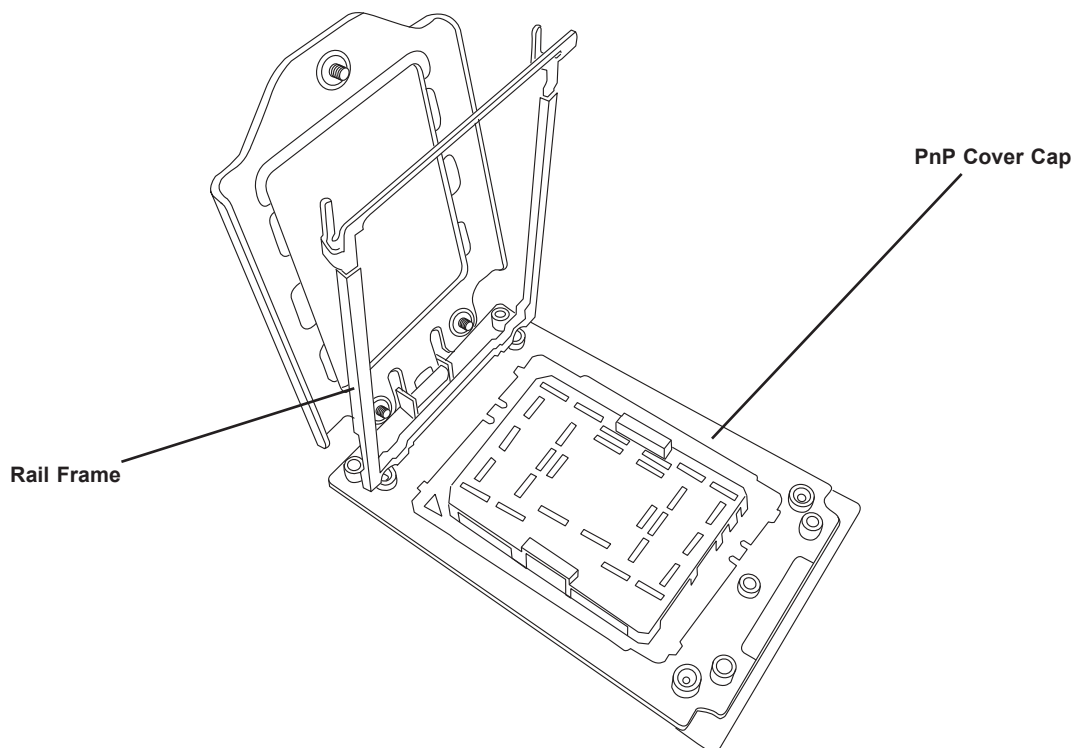

5. Remove the External Cap from the Rail Frame by pulling it upwards through the rail guides on the Rail Frame.

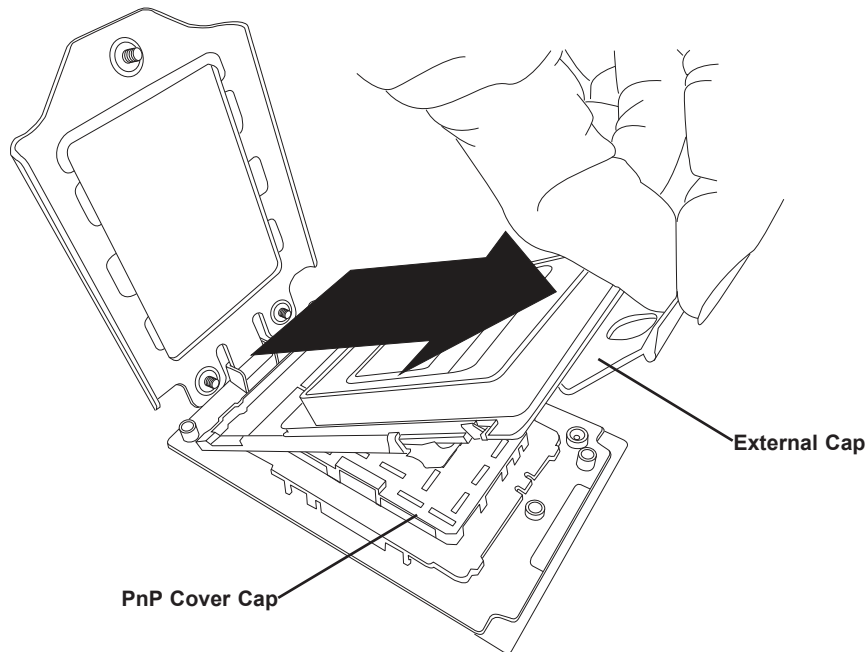

6. The CPU Package is shipped from the factory with the Carrier Frame pre-assembled. Grip the handle of the Carrier Frame/CPU Package assembly from its shipping tray, and while gripping the handle, align the flanges of the Carrier Frame onto the rails of the Rail Frame so its pins will be at the bottom when the Rail Frame is lowered later.
7. Slide the Carrier Frame/CPU Package downwards to the bottom of the Rail Frame. Ensure the flanges are secure on the rails as you lower it downwards.

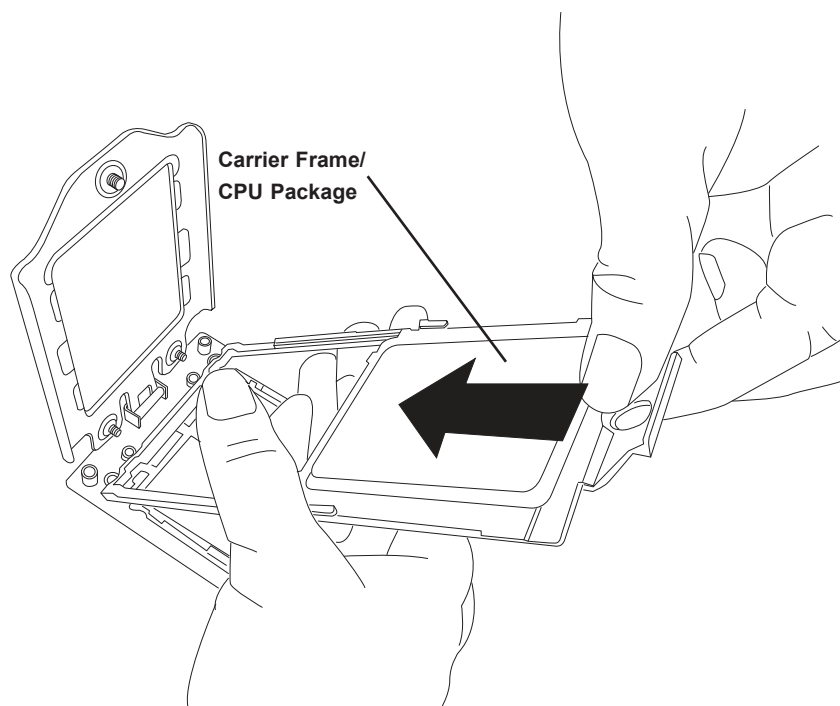

Note: You can only install the CPU inside the socket in one direction with the handle at the top. Make sure that it is properly inserted into the CPU socket before closing the Rail Frame plate. If it doesn't close properly, do not force it as it may damage your CPU. Instead, open the Rail Frame plate again, and double-check that the CPU is aligned properly.

8. Lift up the Rail Frame till it securely rests in upright position. Then remove the PnP Cover Cap from the CPU socket below. Grip the two lift tabs marked "Remove" at the middle of the cap and pull vertically upwards to remove the PnP Cover Cap.

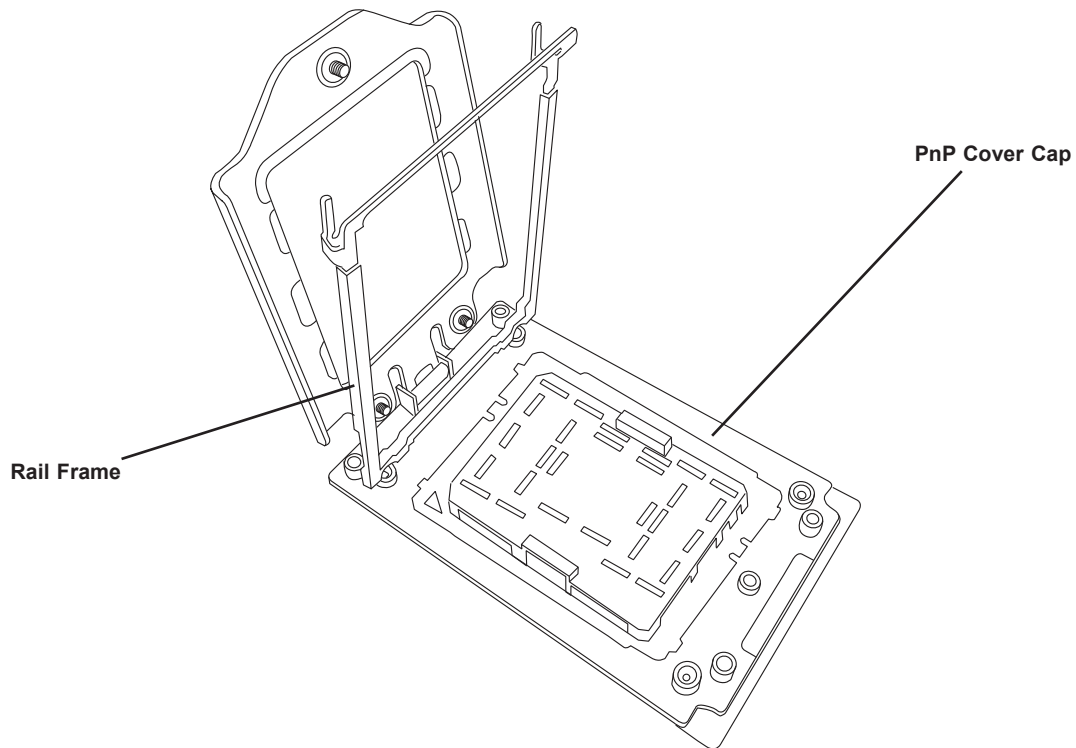

Warning! The exposed socket contacts are extremely vulnerable and can be damaged easily. Do not touch or drop objects onto the contacts and be careful removing the PnP Cover Cap and when placing the Rail Frame over the socket.

9. Gently lower the Rail Frame down onto the socket until the latches on the Rail Frame engage with the Socket housing, and it rests in place. **DO NOT** force it into place!

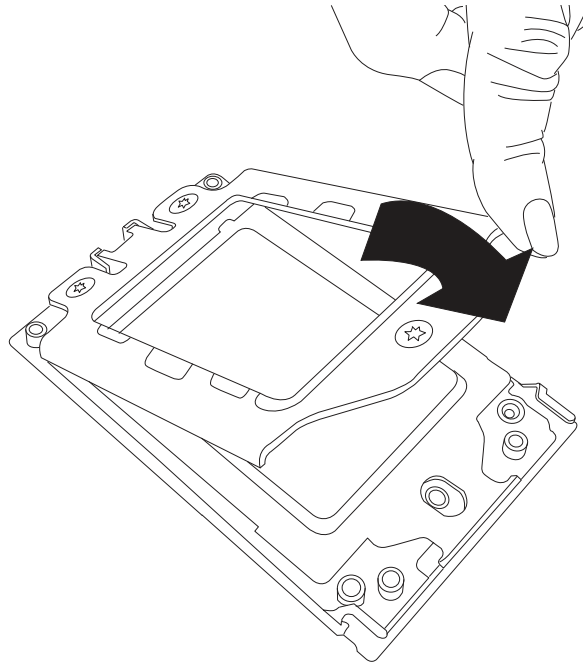

10. Gently lower the Force Frame down onto the Rail Frame and hold it in place until it is seated in the Socket housing. Note that the Force Frame is spring loaded and has to be held in place before it is secured. **Important: Use a torque screwdriver, set it at 16.1 kgf-cm (14.0 lbf-in) with a Torx T20 screw head bit, to prevent damage to the CPU.**

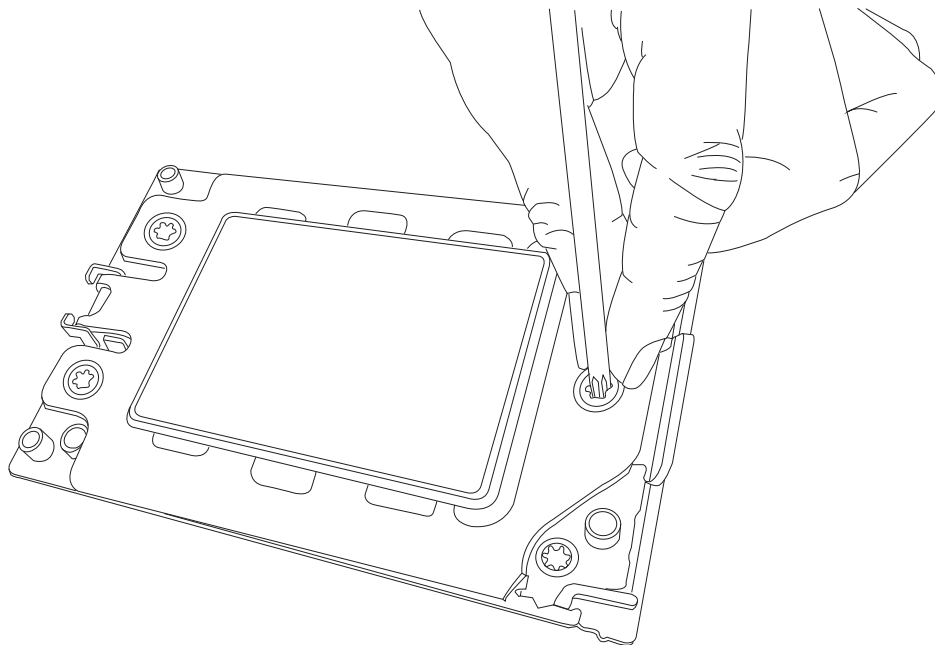

11. Place and re-screw the screws in the reverse order to the way you removed them (holes 1-2-3 in order). When finished, the Force Frame will be secure over both the Rail Frame and CPU Package.

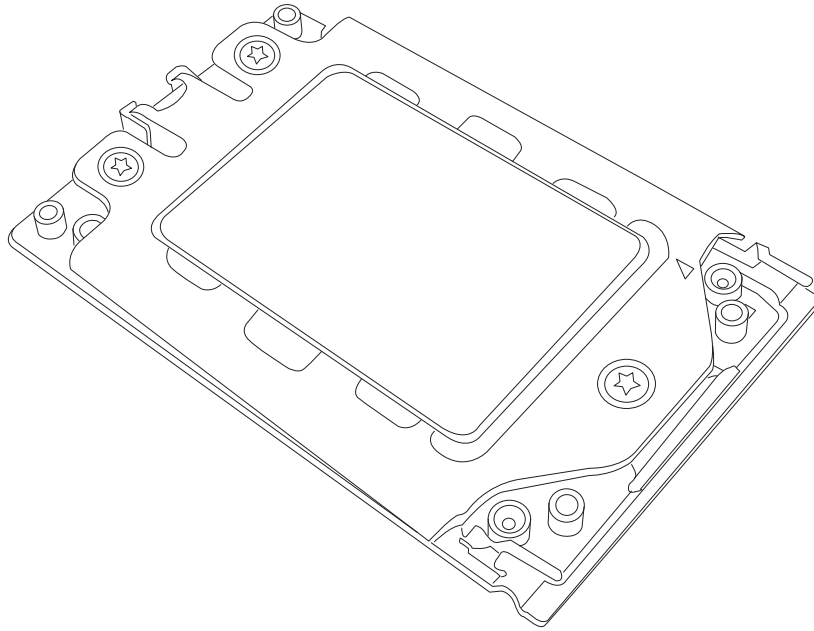

- After the Force Frame is secured and the CPU package is in place, now you must install the heatsink to the frame. Lower the heatsink down till it rests securely over the four screw holes on CPU Package on the socket frame.

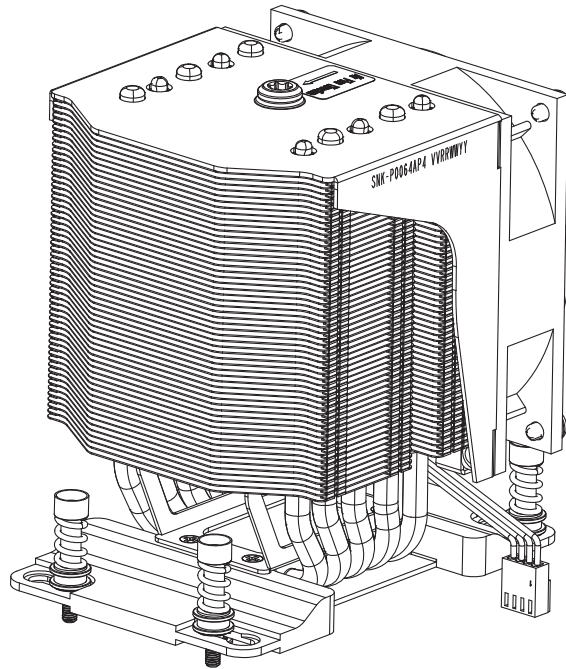

- As illustrated, tighten the four screws down on the heatsink in a diagonal pattern till it is secured. The heatsink will now be secured and you have finished installing the processor and heatsink onto the motherboard. Repeat this procedure for any remaining CPU sockets on the Motherboard.

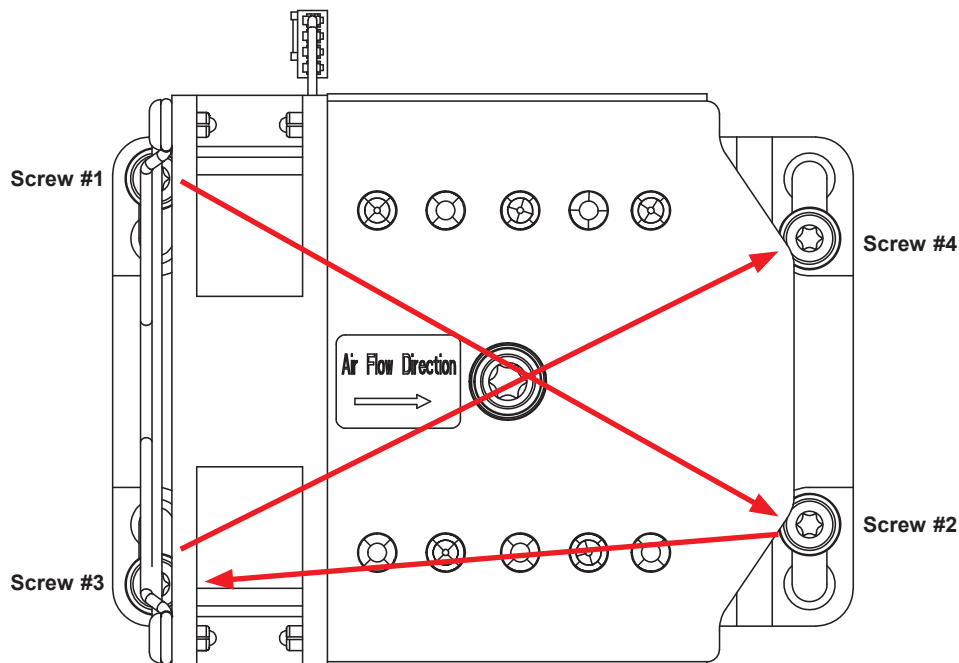

Un-installing the Processor and Heatsink

1. Remove the heatsink attached to the top of the CPU Package by reversing the installation procedure.
2. Clean the Thermal grease left by the heatsink on the CPU package lid to limit the risk of it contaminating the CPU package land pads or contacts in the socket housing.
3. Reverse the procedure for installing the Force Frame onto the socket, unscrewing the plate in the 3-2-1 screw order and lift the Force Frame to the vertical position.
4. Lift the Rail Frame using the lift tabs near the front end of the Rail Frame. Note that the Rail Frame is spring loaded, so be careful lifting it up into a vertical position.
5. Grip the handle of the Carrier Frame and pull upwards to extract it from the Rail Frame. Return the Carrier Frame/CPU Package to its original shipping container.
6. Grip the handle on the External Cap and return it to the Rail Frame sliding it downwards till it rests in the frame.
7. Gripping the Rail Frame, rotate it downwards till it rests above and locks over the socket housing in its horizontal position.
8. Push and rotate down the Force Frame till it is over the External Cap and Rail Frame into a horizontal position.
9. While holding down the Force Frame, secure it back to the socket frame by securing screw 1 in place. Note that without a CPU Package in place, it is not necessary to tighten down screws 2 and 3 at this time.

2.4 Memory Support and Installation

Note: Check the Supermicro website for recommended memory modules.

Important: Exercise extreme care when installing or removing DIMM modules to prevent any possible damage.

Memory Support

The M12SWA-TF supports up to 2TB of ECC RDIMM MT/s or ECC/non-ECC UDIMM in 8 DIMM slots. Refer to the table below for additional memory information.

DIMM Module Population Sequence

When installing memory modules, the DIMM slots should be populated in the following order: DIMMC1, DIMMD1, DIMMG1, DIMMH1, DIMMA1, DIMME1, DIMMB1, DIMMF1.

- It is recommended that DDR4 DIMM modules of the same size, type, and speed should be installed.
- The motherboard will support odd-numbered modules (1 or 3 modules installed). However, to achieve the best memory performance, fully populate the motherboard with validated memory modules.

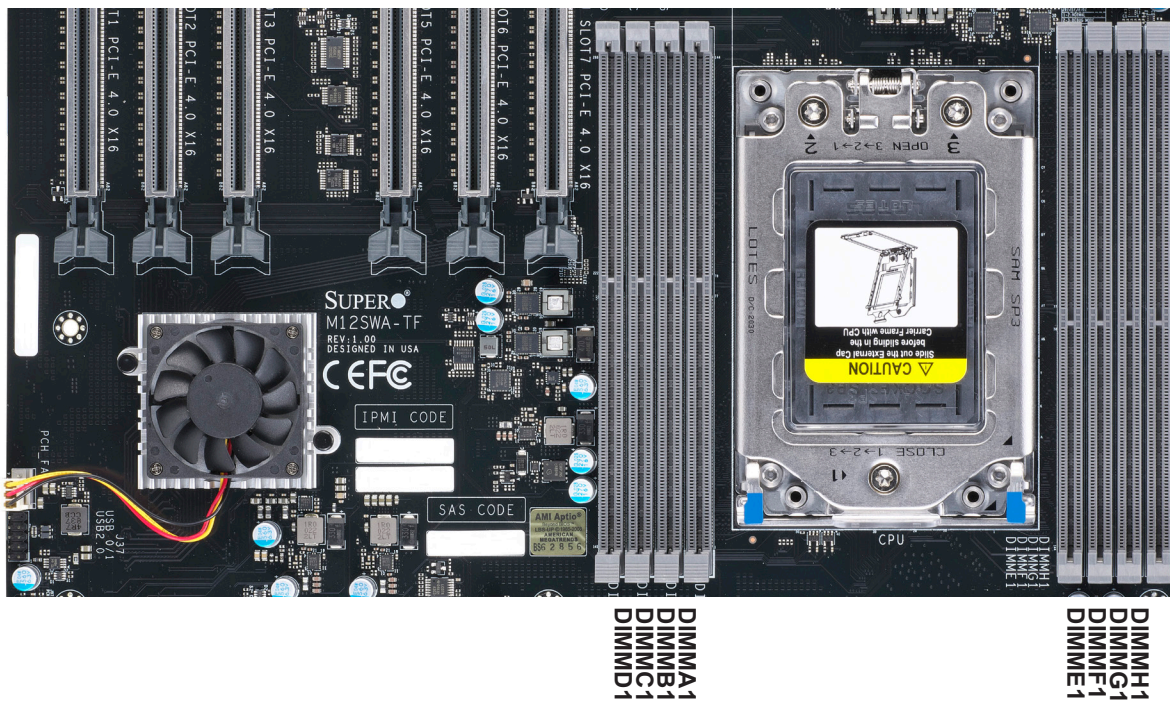

Figure 2-2. DIMM Numbering

DIMM Population Guide								
CPU#	Channel							
	D1	C1	B1	A1	E1	F1	G1	H1
1 DIMM								
CPU1		V						
2 DIMMs								
CPU1	V	V						
4 DIMMs								
CPU1	V	V					V	V
6 DIMMs								
CPU1	V	V		V	V		V	V
8 DIMMs								
CPU1	V	V	V	V	V	V	V	V

Note: Most configurations populating fewer than eight channels are supported, but not recommended.

DIMM Installation

1. Insert the desired number of DIMMs into the memory slots, starting with DIMMC1, DIMMD1, DIMMG1, DIMMH1, DIMMA1, DIMME1, DIMMB1, DIMMF1. For best performance, please use the memory modules of the same type and speed.
2. Align the DIMM module key with the receptive point on the single-latch DIMM slot.
3. Push the release tab outwards to unlock the slot.
4. Align the notch on the end of the module against the receptive point on the end of the slot.
5. Press both ends of the module straight down into the slot until the module snaps into place.
6. Press the release tab to the lock position to secure the DIMM module into the slot.

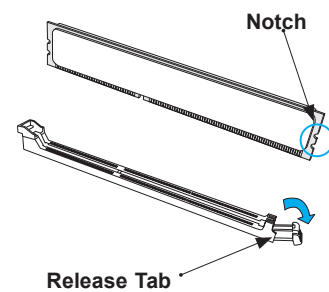
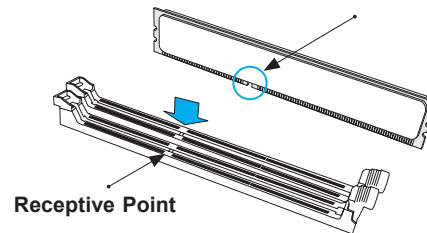
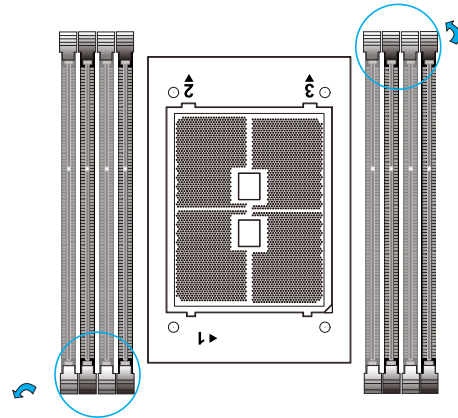

DIMM Removal

Reverse the steps above to remove the DIMM modules from the motherboard.

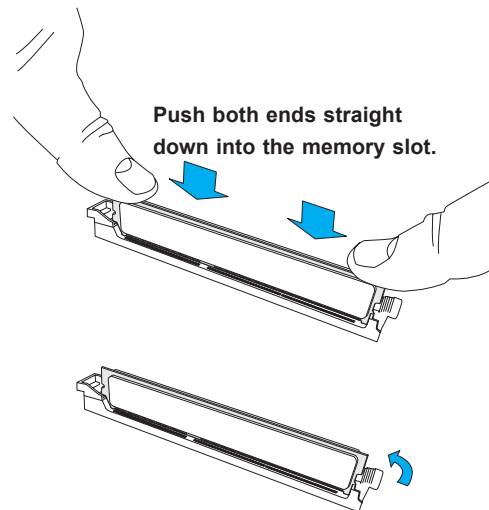

2.6 Rear I/O Ports

See Figure 2-1 below for the locations and descriptions of the various I/O ports on the rear of the motherboard.

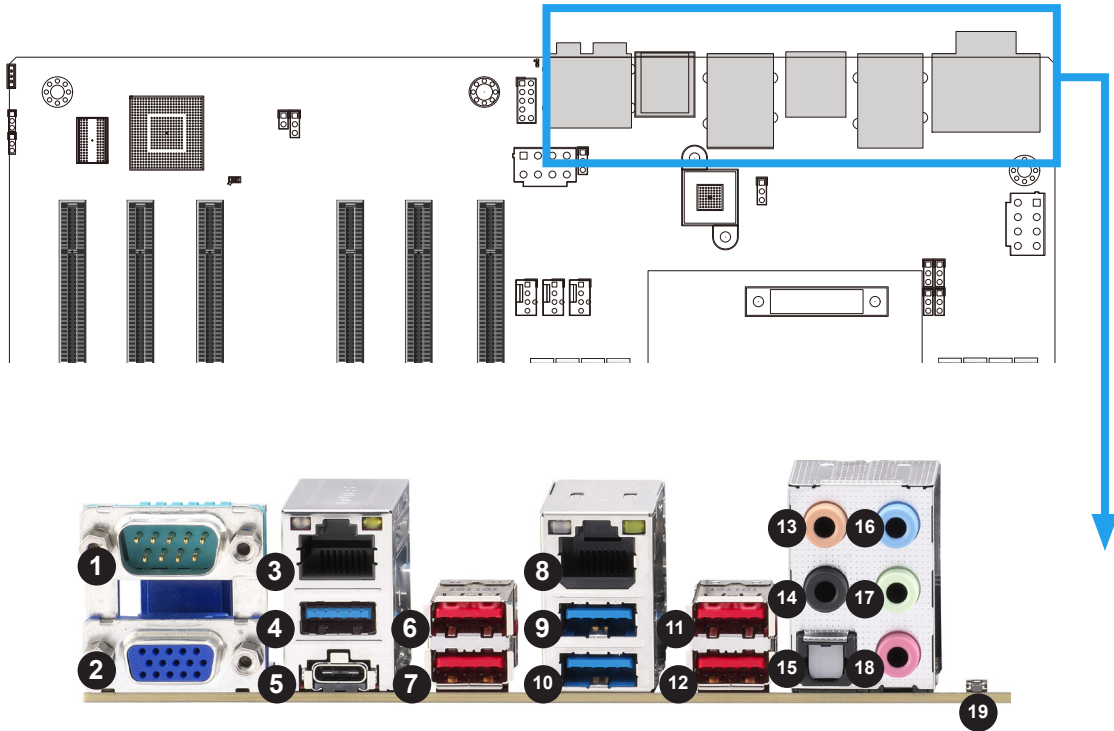

Figure 2-1. I/O Port Locations and Definitions

Rear I/O Ports							
#	Description	#	Description	#	Description	#	Description
1.	COM1	6.	USB6: USB3.2 Gen2 (Type A, 10Gb/s)	11.	USB 2: USB3.2 Gen2 (Type A, 10Gb/s)	16.	Line In
2.	VGA Port	7.	USB7: USB3.2 Gen2 (Type A, 10Gb/s)	12.	USB 3: USB3.2 Gen2 (Type A, 10Gb/s)	17.	Line Out
3.	1Gb LAN Port (i210)	8.	10Gb LAN Port (AQC113C)	13.	Center/LFE Out	18.	Mic In
4.	USB12: USB3.2 Gen1 (Type A, 5Gb/s)	9.	USB 4: USB3.2 Gen1 (Type A, 5Gb/s)	14.	Surround Out	19.	UID Switch
5.	USB8: USB3.2 Gen2x2 (Type C, 20Gb/s)	10.	USB5: USB3.2 Gen1 (Type A, 5Gb/s)	15.	S/PDIF Out		

1. COM Port

There is one serial communications port (COM1) on the rear I/O panel.

2. VGA Port

There is one VGA port on the rear I/O panel

3. 1Gb LAN Port (i210)

There is one 1Gb LAN port located on the I/O back panel.

4. USB 12: USB3.2 Gen1 (Type A, 5Gb)

There is one USB3.2 port on the I/O back panel. It supports the type A connector.

5. USB 8: USB3.2 Gen2x2 (Type C, 20Gb)

There is one USB3.2 port on the I/O back panel. It supports the type C connector.

6~7. USB 6 and USB 7: USB3.2 Gen2 (Type A, 10Gb)

These two USB3.2 ports on the I/O back panel support the type A connector.

8. 10Gb LAN Port (AQC113C)

There is one 10Gb LAN port located on the I/O back panel.

9~10. USB 4 and USB 5: USB3.2 Gen 1 (Type A, 5Gb)

These two USB3.2 ports on the I/O back panel support the type A connector.

11~12. USB 2 and USB 3: USB3.2 Gen 2 (Type A, 10Gb)

These two USB3.2 ports on the I/O back panel support the type A connector.

13~14. Center/LFE Out and Surround Out

This motherboard features a 7.1+2 Channel High Definition Audio (HDA) codec that provides 10 DAC channels. The HD Audio connections simultaneously supports multiple-streaming 7.1 sound playback with two channels of independent stereo output through the front panel stereo out for front, rear, center and subwoofer speakers. To enable this function, download the advanced software for this motherboard.

CEN/LFE is the audio output for the center channel and low frequency channel.

15. S/PDIF Out

This is a fibre optic audio output for a TOSLINK connector and cable.

16. Line In

This type of connector attaches audio devices.

17. Line Out

This is a headphone jack.

18. Mic In

This is a microphone jack.

19. UID Switch

A Unit Identifier (UID) switch is located on the I/O backpanel. The rear UID LED is located next to the UID switch. When you press the UID switch, both rear and front UID LED indicators will turn on. Press the UID switch again to turn off the LED indicators. The UID Indicator provides easy identification of a system that may be in need of service.

Note: UID can also be triggered via IPMI on the serverboard. For more information on IPMI, please refer to the IPMI User's Guide posted on our website at <http://www.supermicro.com>

2.7 Front Control Panel

JF1 contains header pins for various buttons and indicators that are normally located on a control panel at the front of the chassis. These connectors are designed specifically for use with Supermicro chassis. See the figure below for the location of JF1.

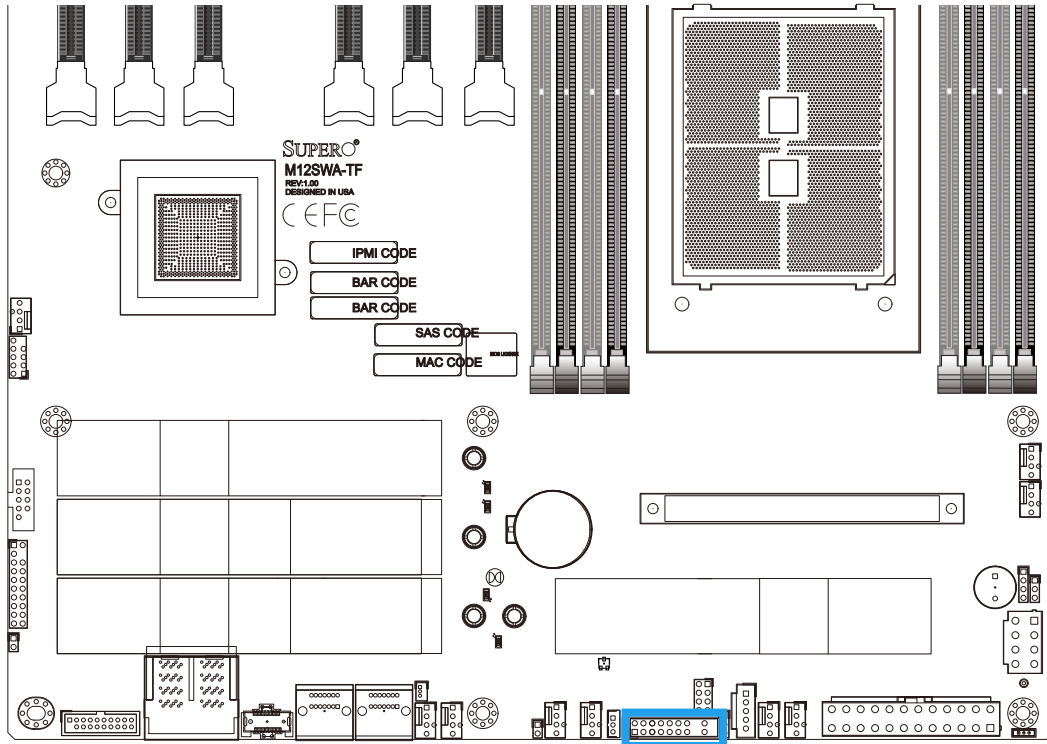

	20	19	
NMI	○	○	X
X	○	○	X
PWR LED	○	○	3.3V
HDD LED	○	○	3.3V Stby
NIC1 Link LED	○	○	3.3V Stby
NIC2 Link LED	○	○	3.3V Stby
UID LED	○	○	3.3V Stby
Power Fail LED	○	○	3.3 V
Ground	○	○	Reset } Reset Button
Ground	○	○	PWR } Power Button
	2	1	

Figure 2-2. JF1 Pin Definitions

2.8 Connectors

ATX Power Supply Connector

The 24-pin power supply connector (JPW1) meets the ATX SSI EPS 12V specification. You must also connect the 8-pin (JPW2~JPW4) CPU power connectors to the power supply.

ATX Power 24-pin Connector Pin Definitions			
Pin#	Definition	Pin#	Definition
13	+3.3V	1	+3.3V
14	-12V	2	+3.3V
15	Ground	3	Ground
16	PS_ON	4	+5V
17	Ground	5	Ground
18	Ground	6	+5V
19	Ground	7	Ground
20	Res (NC)	8	PWR_OK
21	+5V	9	5VSB
22	+5V	10	+12V
23	+5V	11	+12V
24	Ground	12	+3.3V

Required Connection

8-Pin Power Connectors

JPW2~JPW4 are 8-pin 12V DC power input for the CPU that must be connected to the power supply. Refer to the table below for pin definitions.

8-pin Power Connectors Pin Definitions	
Pin#	Definition
1 - 4	Ground
5 - 8	+12V

Required Connection

Important:

- To provide adequate power supply to the motherboard, be sure to connect the 24-pin ATX PWR and the 8-pin PWR connectors (JPW2, JPW3 and JPW4) to the power supply. Failure to do so may void the manufacturer warranty on your power supply and motherboard.
- For installing multiple GPU cards, it is required to connect the 8-pin connectors (JPW2, JPW3 and JPW4) to the power supply. Please refer to the tables below.

GPU Cards and the Required Connectors					
Type of GPU	Number of GPU Cards	JPW1	JPW2	JPW3	JPW4
Single-Width	GPU X 1	V		V	V
	GPU X 2	V		V	V
	GPU X 3	V		V	V
	GPU X 4 or more	V	V	V	V
Double-Width	GPU X 1	V		V	V
	GPU X 2	V		V	V
	GPU X 3	V	V	V	V
	GPU X 4 or more	V	V	V	V
Triple-Width	GPU X 1	V		V	V
	GPU X 2	V	V	V	V

Front Panel External Speaker (JD1)

If you wish to use an external speaker, attach an external speaker to pins 6~7. See the table below for pin definitions.

Speaker Connector Pin Definitions	
Pins#	Definition
1~2	Power LED
6~7	External Speaker

10-Pin Audio Header (J31)

A 10-pin front panel audio header (J31) is located on the motherboard allows you to use the onboard sound for audio playback. Connect an audio cable to the this header to use this feature. Refer to the table below for pin definitions.

10-Pin Audio Header Pin Definitions			
Pin#	Definition	Pin#	Definition
1	Mic_2_Left	2	Audio_Ground
3	Mic_2_Right	4	Audio_Detect
5	Line_2_Right	6	Mic_2_JD
7	Jack_Detect	8	Key
9	Line_2_Left	10	Line_2_JD

Standby Power Header

The Standby Power header is located at JSTBY1 on the motherboard.

Standby Power Pin Definitions	
Pin#	Definition
1	+5V Standby
2	Ground
3	Wake-up

FAN Headers

There are four system fan headers (FANA~FAND) and six CPU fan headers (FAN1~FAN6) on this motherboard. These are 4-pin fan headers; pins 1-3 are backward compatible with traditional 3-pin fans. The onboard fan speeds are controlled by Thermal Management (via Hardware Monitoring) in the BMC. When using Thermal Management setting, please use all 4-pin fans.

System Fan Headers Pin Definitions	
Pin#	Definition
1	Ground
2	+12V (Red)
3	Tachometer
4	PWM Control

Serial ATA (SATA 3.0) Ports (6Gb/second)

The M12SWA-TF motherboard has four available SATA 3.0 ports (SATA0~3). They are standard SATA 3.0 ports.

SATA Connectors Pin Definitions	
Pin#	Definition
1	Ground
2	SATA_TXP
3	SATA_TXN
4	Ground
5	SATA_RXN
6	SATA_RXP
7	Ground

SPDIF (Sony/Philips Digital Interface) Out Header

The SPDIF Out (JSPDIF_OUT) is used for digital audio output. You will also need the appropriate cable to use these features.

SPDIF_OUT Pin Definitions	
Pin#	Definitions
1	S/PDIF_Out
2	Ground

Universal Serial Bus (USB)

Two Universal Serial Bus 2.0 ports (USB0/1) are located on the front panel of the M12SWA-TF. In addition, two Type A USB 3.2 headers (USB10/11) and one Type C USB 3.2 header (USB9) are located on the front panel of the M12SWA-TF. See the tables below for pin definitions

Front Panel USB 3.0 Pin Definitions			
Pin#	Definition	Pin#	Definition
1	VBUS	11	USB_P
2	Stda_SSRX-	12	USB_N
3	Stda_SSRX+	13	GND
4	GND	14	USB3_TP
5	Stda_SSTX-	15	USB3_TN
6	Stda_SSTX+	16	GND
7	GND	17	USB3_RP
8	D-	18	USB3_RN
9	D+	19	Power
10		x	

Front Panel USB 3.2 Pin Definitions			
Pin#	Definition	Pin#	Definition
1	VBUS	11	USB_P
2	Stda_SSRX-	12	USB_N
3	Stda_SSRX+	13	GND
4	GND	14	USB3_TP
5	Stda_SSTX-	15	USB3_TN
6	Stda_SSTX+	16	GND
7	GND	17	USB3_RP
8	D-	18	USB3_RN
9	D+	19	Power
10		x	

SATA DOM Power Connector (JSD1)

One power connector for SATA DOM (Disk On Module) device is located at JSD1. Connect an appropriate cable here to provide power support for your DOM device.

SATA DOM PWR Pin Definitions	
Pin#	Definition
1	+5V
2	Ground
3	Ground
19	NC

Chassis Intrusion Header

A Chassis Intrusion header is located at JL1 on the motherboard. Attach the appropriate cable from the chassis to the header to inform you when the chassis is opened.

Chassis Intrusion Pin Definitions	
Pin#	Definitions
1	Intrusion Input+
2	Intrusion Input-

Overheat LED Header

The JOH1 header is used to connect an LED to provide warnings of chassis overheat. This LED will also blink to indicate a fan failure. Refer to the table below for pin definitions.

The M12SWA-TF has four SATA 3.0 ports through the P1-PCIe1A port and HDD backplane board BPN-NVMe4-228N-S4 with a specific cable.

Overheat LED Header Pin Definitions	
Pin#	Definitions
1	Intrusion Input+
2	Intrusion Input-

Power Supply SMBus I²C Header)

The Power System Management Bus (I²C) header at JPI2C monitors the power supply input/output voltages, fans, temperatures, and status. Refer to the table below for pin definitions.

Power SMBus Header Pin Definitions	
Pin#	Definitions
1	Clock
2	Data
3	PMBUS_Alert
4	Ground
5	+3.3V

TPM Header/Port 80 Connector

The JTPM1 header is used to connect a Trusted Platform Module (TPM), which is available from a third-party vendor. A TPM is a security device that supports encryption and authentication in hard drives. It enables the motherboard to deny access if the TPM associated with the hard drive is not installed in the system.

Please go to the following link for more information on TPM: <http://www.supermicro.com/manuals/other/TPM.pdf>.

Trusted Platform Module Header Pin Definitions			
Pin#	Definition	Pin#	Definition
1	LCLK	2	GND
3	LFRAME#	4	
5	LRESET#	6	NC
7	LAD3	8	LAD2
9	3.3V	10	LAD1
11	LAD0	12	GND
13	NC	14	NC
15	3.3V_STBY	16	SERIRQ
17	GND	18	NC
19	NC	20	NC

2.9 Jumper Settings

How Jumpers Work

To modify the operation of the motherboard, jumpers can be used to choose between optional settings. Jumpers create shorts between two pins to change the function of the connector. Pin 1 is identified with a square solder pad on the printed circuit board. See the diagram below for an example of jumping pins 1 and 2. Refer to the motherboard layout page for jumper locations.

Note: On two-pin jumpers, "Closed" means the jumper is on and "Open" means the jumper is off the pins.

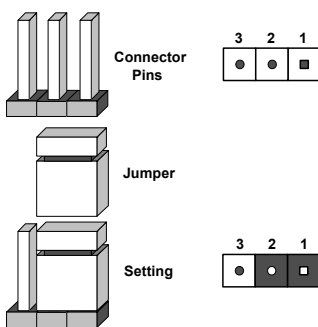

CMOS Clear

JBT1 is used to clear CMOS, which will also clear any passwords. Instead of pins, this jumper consists of contact pads to prevent accidentally clearing the contents of CMOS.

To Clear CMOS

1. First power down the system and unplug the power cord(s).
2. Remove the cover of the chassis to access the motherboard.
3. Remove the CMOS battery from the motherboard.
4. Short the CMOS pads with a metal object such as a small screwdriver for at least four seconds.
5. Remove the screwdriver (or shorting device).
6. Re-install the CMOS battery on the motherboard.
7. Replace the cover, reconnect the power cord(s), and power on the system.

Note: Clearing CMOS will also clear all passwords.



HD Audio Enable/Disable

JPAC1 enables or disables Audio Controller on the motherboard. See the table below for jumper settings. The default setting is Enabled

HD Audio Enable/Disable Jumper Settings	
Jumper Setting	Definition
Pins 1-2	Enabled (Default)
Pins 2-3	Disabled

LAN1/LAN2 Enable/Disable

Use JPL1 and JPL2 to enable or disable LAN ports 1 and 2 respectively on the motherboard. Refer to the table below for jumper settings. The default setting is Enabled.

LAN1/LAN2 Enable/Disable Jumper Settings	
Jumper Setting	Definition
Pins 1-2	Reset (Default)
Pins 2-3	Disabled

USB6/7 Wake Up

Use the jumper JPUSB1 to "wake-up" your system by pressing a key on a USB keyboard or clicking the USB mouse connected to the backpanel USB ports 6/7. JPUSB1 is used together with a USB Wake-Up feature in the BIOS. Enable this jumper and the USB support in the BIOS to wake up your system via USB devices.

JPUSB1 Jumper Settings	
Jumper Setting	Definition
Pins 1-2	Enabled (Default)
Pins 2-3	Disabled

USB12 Enable/Disable

JP5 jumper enables or disables USB12.

USB12 Jumper Settings	
Jumper Setting	Definition
Pins 1-2	Enabled (Default)
Pins 2-3	Disabled

Watch Dog

JWD1 controls the Watch Dog function. Watch Dog is a monitor that can reboot the system when a software application hangs. Jumping pins 1-2 will cause Watch Dog to reset the system if an application hangs. Jumping pins 2-3 will generate a non-maskable interrupt (NMI) signal for the application that hangs. Watch Dog must also be enabled in BIOS. The default setting is Reset.

Note: When Watch Dog is enabled, the user needs to write their own application software to disable it.

Watch Dog Jumper Settings	
Jumper Setting	Definition
Pins 1-2	Reset (Default)
Pins 2-3	NMI
Open	Disabled

2.10 LED Indicators

M.2-0LED, M.2-1LED, M.2-2LED, M.2-3LED

Three M.2 indicators blinks green when they are functioning normally.

Onboard Power LED Indicator	
LED Color	Definition
Blinking Green	Device working

BMC Heartbeat LED

A BMC Heartbeat LED is located at LEDM1 on the serverboard. When LEDM1 is blinking, BMC functions normally. See the table below for more information.

BMC Heartbeat LED States		
Color	State	Definition
Green	Solid On	BMC is not ready.
Green	Blinking	BMC Normal
Green	Fast Blinking	BMC: Initializing

Onboard Power LED

When this LED is lit, it means system is in power-on state, and the onboard power status is ok. Turn off the system and unplug the power cord before removing or installing components.

Onboard Power LED Indicator	
LED Color	Definition
Off	System Off (power cable not connected)
Green	System On, Power OK

UID LED

The UID LED (LE) is located next to the UID switch. When you press the UID switch, the UID LED will be turned on. Press the UID switch again to turn off the LED indicator. The UID Indicator provides easy identification of a system unit that may be in need of service.

UID LED	
LED Color	Definition
Blue On	Unit Identified

Power LED

The Power LED connection is located under an M.2 NVMe.

UID LED	
LED Color	Definition
Blinking Green	Power On

Chapter 3

Troubleshooting

3.1 Troubleshooting Procedures

Use the following procedures to troubleshoot your system. If you have followed all of the procedures below and still need assistance, refer to the 'Technical Support Procedures' and/or 'Returning Merchandise for Service' section(s) in this chapter. Always disconnect the AC power cord before adding, changing or installing any non hot-swap hardware components.

Before Power On

1. Check that BMC LED is blinking before the motherboard is turned on.
2. Make sure that the power connector is connected to your power supply.
3. Make sure that no short circuits exist between the motherboard and chassis.
4. Disconnect all cables from the motherboard, including those for the keyboard and mouse.
5. Remove all add-on cards.
6. Install a CPU, a heatsink, and at least one DIMM on the motherboard. Check all jumper settings properly. Make sure that the heatsink is fully seated.
7. Use the correct type of onboard CMOS battery (CR2032) as recommended by the manufacturer. To avoid possible explosion, do not install the CMOS battery upside down.

No Power

1. Make sure that no short circuits exist between the motherboard and the chassis.
2. Verify that all jumpers are set to their default positions.
3. Check that the 115V/230V switch on the power supply is properly set.
4. Turn the power switch on and off to test the system.
5. The CMOS battery on your motherboard may be old. Check to verify that it still supplies ~3V DC. If it does not, replace it with a new one.

No Video

1. Check that the VGA cable is connected properly, and the monitor is on.
2. Check if you follow the guidelines to install the memory module (see DIMM Module Population in chapter 2).
3. Reseat the memory DIMM module.

System Boot Failure

If the system does not display POST (Power-On-Self-Test) or does not respond after the power is turned on, check the following:

1. Clear the CMOS settings by unplugging the power cord and contacting both pads on the CMOS Clear Jumper (JBT1). Refer to chapter 2.
2. Remove all components from the motherboard, especially the DIMM modules.
3. Turn on the system with only one DIMM module installed. If the system boots, check for bad DIMM modules or slots by following the Memory Errors Troubleshooting procedure in this Chapter.

Memory Errors

1. Make sure that the DIMM modules are properly and fully installed.
2. Confirm that you are using the correct memory. Also, it is recommended that you use the same memory type and speed for all DIMMs in the system. See Section 2.4 for memory details.
3. Check for bad DIMM modules or slots by swapping modules between slots and noting the results.
4. Check the power supply voltage 115V/230V switch.

What to do if the System is Losing the Setup Configuration

1. Make sure that you are using a high quality power supply. A poor quality power supply may cause the system to lose the CMOS setup information. Refer to Section 1 for details on power supplies.

2. The battery on your motherboard may be old. Check to verify that it still supplies ~3V DC. If it does not, replace it with a new one.
3. If the above steps do not fix the setup configuration problem, contact your vendor for repairs.

When the System Becomes Unstable

A. If the system becomes unstable during or after OS installation, check the following:

1. CPU/BIOS support: Make sure that your CPU is supported and that you have the latest BIOS installed in your system.
2. Memory support: Make sure that the memory modules are supported by testing the modules using memtest86 or a similar utility.
Note: Refer to the product page on our website at <http://www.supermicro.com> for memory and CPU support and updates.
3. HDD support: Make sure that all hard disk drives (HDDs) work properly. Replace the bad HDDs with good ones.
4. System cooling: Check the system cooling to make sure that all heatsink fans and CPU/system fans, etc., work properly. Check the hardware monitoring settings in the IPMI to make sure that the CPU and system temperatures are within the normal range. Also check the front panel Overheat LED and make sure that it is not on.
5. Adequate power supply: Make sure that the power supply provides adequate power to the system. Make sure that all power connectors are connected. Please refer to our website for more information on the minimum power requirements.
6. Proper software support: Make sure that the correct drivers are used.

B. If the system becomes unstable before or during OS installation, check the following:

1. Source of installation: Make sure that the devices used for installation are working properly, including boot devices such as USB flash or media drives.
2. Cable connection: Check to make sure that all cables are connected and working properly.
3. Using the minimum configuration for troubleshooting: Remove all unnecessary components (starting with add-on cards first), and use the minimum configuration (but with a CPU and a memory module installed) to identify the trouble areas. Refer to the steps listed in Section A above for proper troubleshooting procedures.

4. Identifying bad components by isolating them: If necessary, remove a component in question from the chassis, and test it in isolation to make sure that it works properly. Replace a bad component with a good one.
5. Check and change one component at a time instead of changing several items at the same time. This will help isolate and identify the problem.
6. To find out if a component is good, swap this component with a new one to see if the system will work properly. If so, then the old component is bad. You can also install the component in question in another system. If the new system works, the component is good and the old system has problems.

3.2 Technical Support Procedures

Before contacting Technical Support, please take the following steps. Also, note that as a motherboard manufacturer, we do not sell directly to end-users, so it is best to first check with your distributor or reseller for troubleshooting services. They should know of any possible problem(s) with the specific system configuration that was sold to you.

1. Please review the 'Troubleshooting Procedures' and 'Frequently Asked Questions' (FAQs) sections in this chapter or see the FAQs on our website before contacting Technical Support.
2. BIOS upgrades can be downloaded from our website.
Note: Not all BIOS can be flashed depending on the modifications to the boot block code.
3. If you still cannot resolve the problem, include the following information when contacting us for technical support:
 - Motherboard model and PCB revision number
 - BIOS release date/version (this can be seen on the initial display when your system first boots up)
 - System configuration

An example of a Technical Support form is posted on our website.

Distributors: For immediate assistance, please have your account number ready when contacting our technical support department by e-mail.

3.3 Frequently Asked Questions

Question: What type of memory does my motherboard support?

Answer: The M12SWA-TF motherboard supports up to 8 DDR4 ECC/non-ECC UDIMM/ ECC RDIMM sockets, with speeds of up to 3200MT/s (1DPC). Max capacity is up to 256GB (UDIMM)/2TB (RDIMM) in 6 PCIe 4.0 x16 slots. See Section 2.4 for details on installing memory.

Question: How do I update my BIOS?

Answer: It is recommended that you **do not** upgrade your BIOS if you are not experiencing any problems with your system. Updated BIOS files are located on our website at <http://www.supermicro.com>. Please check our BIOS warning message and the information on how to update your BIOS on our website. Select your motherboard model and download the BIOS file to your computer. Also, check the current BIOS revision to make sure that it is newer than your BIOS before downloading. You can choose from the zip file and the .exe file. If you choose the zip BIOS file, please unzip the BIOS file onto a bootable USB device. Run the batch file using the format FLASH.BAT filename.rom from your bootable USB device to flash the BIOS. Then, your system will automatically reboot.

Question: Why can't I turn off the power using the momentary power on/off switch?

Answer: The instant power off function is controlled in BIOS by the Power Button Mode setting. When the On/Off feature is enabled, the motherboard will have instant off capabilities as long as the BIOS has control of the system. When the 4 Seconds Override feature is enabled or when the BIOS is not in control such as during memory count (the first screen that appears when the system is turned on), the momentary on/off switch must be held for more than four seconds to shutdown the system. This feature is required to implement the ACPI features on the motherboard.

3.4 Returning Merchandise for Service

A receipt or copy of your invoice marked with the date of purchase is required before any warranty service will be rendered. You can obtain service by calling your vendor for a Returned Merchandise Authorization (RMA) number. When returning to the manufacturer, the RMA number should be prominently displayed on the outside of the shipping carton and mailed prepaid or hand-carried. Shipping and handling charges will be applied for all orders that must be mailed when service is complete.

For faster service, RMA authorizations may be requested online (<http://www.supermicro.com/support/rma/>).

This warranty only covers normal consumer use and does not cover damages incurred in shipping or from failure due to the alteration, misuse, abuse or improper maintenance of products.

During the warranty period, contact your distributor first for any product problems.

3.5 Battery Removal and Installation

Battery Removal

To remove the onboard battery, follow the steps below:

1. Power off your system and unplug your power cable.
2. Locate the onboard battery as shown below.
3. Using a tool such as a pen or a small screwdriver, push the battery lock outwards to unlock it. Once unlocked, the battery will pop out from the holder.
4. Remove the battery.

Proper Battery Disposal

Please handle used batteries carefully. Do not damage the battery in any way; a damaged battery may release hazardous materials into the environment. Do not discard a used battery in the garbage or a public landfill. Please comply with the regulations set up by your local hazardous waste management agency to dispose of your used battery properly.

Battery Installation

1. To install an onboard battery, follow the steps 1 & 2 above and continue below:
2. Identify the battery's polarity. The positive (+) side should be facing up.
3. Insert the battery into the battery holder and push it down until you hear a click to ensure that the battery is securely locked.

Important: When replacing a battery, be sure to only replace it with the same type.

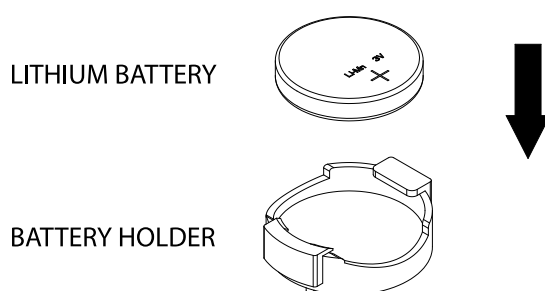

Chapter 4

UEFI BIOS

4.1 Introduction

This chapter describes the AMIBIOS™ setup utility for the M12SWA-TF motherboard. The BIOS is stored on a chip and can be easily upgraded using a flash program.

Note: Due to periodic changes to the BIOS, some settings may have been added or deleted and might not yet be recorded in this manual. Please refer to the Manual Download area of our website for any changes to the BIOS that may not be reflected in this manual.

Starting the Setup Utility

To enter the BIOS setup utility, press the <Delete> key while the system is booting-up. (In most cases, the <Delete> key is used to invoke the BIOS setup screen. There are a few cases when other keys are used, such as <F1>, <F2>, etc.) Each main BIOS menu option is described in this manual.

The Main BIOS screen has two main frames. The left frame displays all the options that can be configured. "Grayed-out" options cannot be configured. The right frame displays the key legend. Above the key legend is an area reserved for a text message. When an option is selected in the left frame, it is highlighted in white. Often a text message will accompany it. (Note that BIOS has default text messages built in. We retain the option to include, omit, or change any of these text messages.) Settings printed in **Bold** are the default values.

A "►" indicates a submenu. Highlighting such an item and pressing the <Enter> key will open the list of settings within that submenu.

The BIOS setup utility uses a key-based navigation system called hot keys. Most of these hot keys (<F1>, <F2>, <F3>, <F4>, <Enter>, <ESC>, <Arrow> keys, etc.) can be used at any time during the setup navigation process.

4.2 Main Setup

When you first enter the AMI BIOS setup utility, you will see the Main setup screen. You can always return to the Main setup screen by selecting the Main tab on the top of the screen. The Main BIOS setup screen is shown below.



System Date/System Time

Use this item to change the system date and time. Highlight *System Date* or *System Time* using the arrow keys. Enter new values using the keyboard. Press the <Tab> key or the arrow keys to move between fields. The date must be entered in Day MM/DD/YYYY format. The time is entered in HH:MM:SS format.

Note: The time is in the 24-hour format. For example, 5:30 P.M. appears as 17:30:00. The date's default value is the BIOS build date after the RTC (Real Time Clock) reset.

Supermicro M12SWA-TF

BIOS Version

This feature displays the version of the BIOS ROM used in the system.

Build Date

This feature displays the date when the version of the BIOS ROM used in the system was built.

Memory Information

Total Memory

This feature displays the total size of memory available in the system.

4.3 Advanced

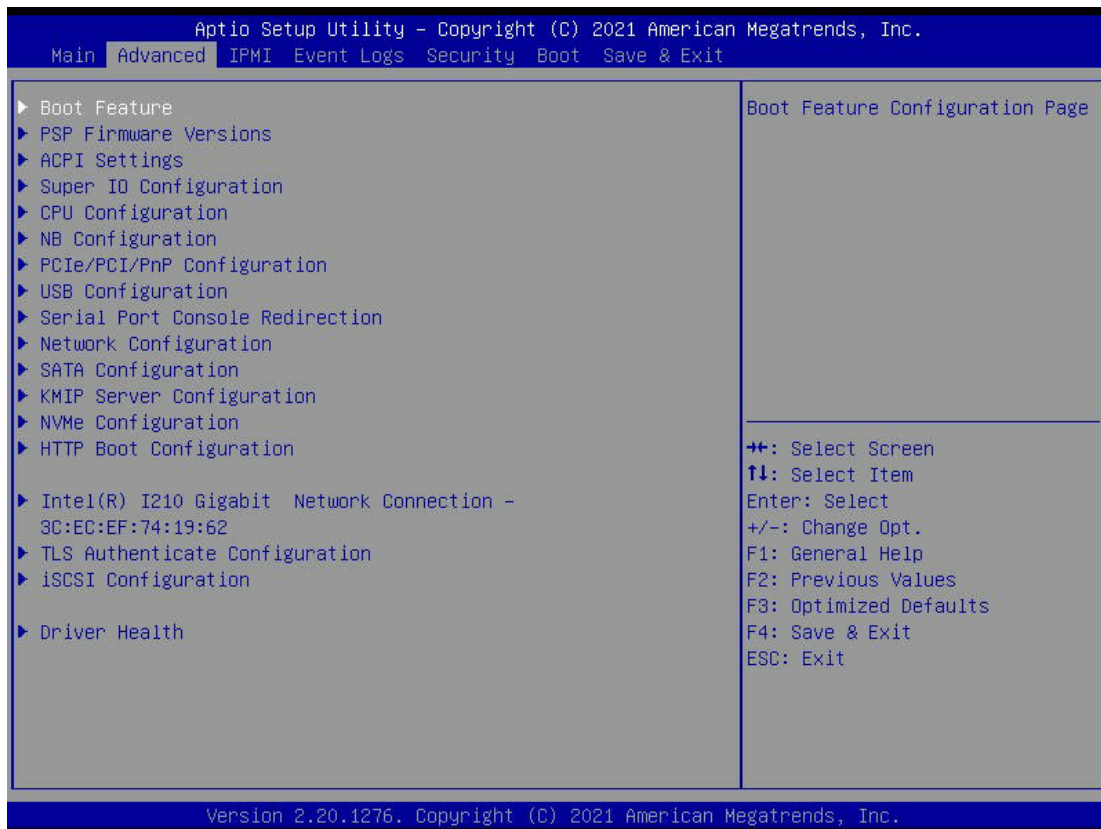

Warning: Take caution when changing the Advanced settings. An incorrect value, a very high DRAM frequency, or an incorrect DRAM timing setting may make the system unstable. When this occurs, revert to the default to the manufacture default settings.

▶ Boot Feature

Quiet Boot

Use this feature to select the screen display between the POST messages and the OEM logo upon bootup. Select Disabled to display the POST messages. Select Enabled to display the OEM logo instead of the normal POST messages. The options are Disabled and **Enabled**.

Option ROM Messages

Use this feature to set the display mode for the Option ROM. Select Keep Current to display the current AddOn ROM setting. Select Force BIOS to use the Option ROM display set by the system BIOS. The options are **Force BIOS** and Keep Current.

Bootup NumLock State

Use this feature to set the Power on state for the <Numlock> key. The options are **On** and Off.

Wait For "F1" If Error

Use this feature to force the system to wait until the <F1> key is pressed if an error occurs. The options are Disabled and **Enabled**.

Re-try Boot

If this item is enabled, the BIOS will automatically reboot the system from a specified boot device after its initial boot failure. The options are **Disabled**, Legacy Boot, and EFI Boot.

Power Configuration**Watch Dog Function**

If enabled, the Watch Dog Timer will allow the system to reset or generate NMI based on jumper settings when it is expired for more than 5 minutes. The options are **Disabled** and Enabled.

Restore on AC Power Loss

Use this feature to set the power state after a power outage. Select Stay-Off for the system power to remain off after a power loss. Select Power-On for the system power to be turned on after a power loss. Select Last State to allow the system to resume its last power state before a power loss. The options are Stay Off, Power On, and **Last State**.

Power Button Function

This feature controls how the system shuts down when the power button is pressed. Select 4 Seconds Override for the user to power off the system after pressing and holding the power button for 4 seconds or longer. Select Instant Off to instantly power off the system as soon as the user presses the power button. The options are **Instant Off** and 4 Seconds Override.

Wake On Lan Enable

This feature enables integrated LAN to wake the system. The options are Disabled and **Enabled**.

Deep S5 Power Policy

Use this feature to configure the Deep S5 Mode configurations. The options are Disabled and **Enabled**.

►PSP Firmware Versions

This section displays the Platform Security Processor (PSP) firmware versions.

- PSP Bootloader Version

- SMU FW Version
- ABL Version
- X570/590 Chipset PSP Version
- X570/590 Chipset SMU Version

►ACPI Settings

PCI AER Support

Use this feature to enable or disable ACPI OS to natively manage PCI Advanced Error Reporting. The options are **Disabled** and **Enabled**.

High Precision Event Timer

The High Precision Event Timer (HPET) can produce periodic interrupts and is used to synchronize multimedia streams, providing smooth playback and reducing the need to use other timestamp calculations. The options are **Disabled** and **Enabled**.

NUMA Node Per Socket

This feature specifies the number of desired Non-Uniform Memory Access (NUMA) nodes per socket. Setting this to zero will attempt to interleave the two sockets together. The options are NPS0, NPS1, NPS2, NPS4 and **Auto**.

ACPI SRAT L3 Cache As NUMA Domain

Use this setting to enable/disable ACPI SRAT L3 Cache As NUMA Domain. The options are **Disabled**, **Enabled** and **Auto**.

►Super IO Configuration

The following Super IO information will display:

Super IO Chip AST2600

►Serial Port 1 Configuration

Serial Port

Select **Enabled** to enable the selected onboard serial port. The options are **Disabled** and **Enabled**.

Device Settings

This item displays the status of a serial part specified by the user.

Change Settings

This feature specifies the base I/O port address and the Interrupt Request address of a serial port specified by the user. Select Auto to allow the BIOS to automatically assign the base I/O and IRQ address. The options are **Auto**, IO=3F8h; IRQ=4, IO=3F8h; IRQ=3, 4, 5, 6, 7, 9, 10, 11, 12, IO=2F8h; IRQ=4, IO=3F8h; IRQ=3, 4, 5, 6, 7, 9, 10, 11, 12, IO=3E8h; IRQ=4, IO=3F8h; IRQ=3, 4, 5, 6, 7, 9, 10, 11, 12, and IO=2E8h; IRQ=4, IO=3F8h; IRQ=3, 4, 5, 6, 7, 9, 10, 11, 12.

► SOL Configuraiton

Serial Port

Select Enabled to enable the selected onboard serial port. The options are Disabled and Enabled.

Device Settings

This item displays the status of a serial part specified by the user.

Change Settings

This feature specifies the base I/O port address and the Interrupt Request address of a serial port specified by the user. Select Auto to allow the BIOS to automatically assign the base I/O and IRQ address. The options are **Auto**, IO=2F8h; IRQ=3, IO=3F8h; IRQ=3, 4, 5, 6, 7, 9, 10, 11, 12, IO=2F8h; IRQ=4, IO=3F8h; IRQ=3, 4, 5, 6, 7, 9, 10, 11, 12, IO=3E8h; IRQ=4, IO=3F8h; IRQ=3, 4, 5, 6, 7, 9, 10, 11, 12, and IO=2E8h; IRQ=4, IO=3F8h; IRQ=3, 4, 5, 6, 7, 9, 10, 11, 12.

Serial Port 2 Attribute

Use this setting to select the serial port 2 mode. The options are **SOL** and COM.

► CPU Configuration

SMT Control

Use this setting to specify Simultaneous Multithreading. Options include Disabled for 1T single thread and **Auto** for 2T two-thread if your system is capable of it.

Core Performance Boost

This setting is used to configure for Core Performance Boost. Options include Disabled and **Auto**.

Global C-state Control

This setting is used to configure for Global C-state Control. Options include Disabled, Enabled and **Auto**.

Local APIC Mode

Use this setting to adjust local APIC mode. Options include xAPIC, x2APIC and **Auto**.

L1 Stream HW Prefetcher / L2 Stream HW Prefetcher

This setting is used to enable or disable the L1/L2 Stream Hardware Prefetcher. The options are Disabled, Enabled and **Auto**.

SVM Mode

This setting Disables or **Enables** CPU Virtualization.

SEV ASID Count

Use this setting to specify the maximum valid ASID. Options include 253 ASIDs, 509 ASIDs and **Auto**.

SEV-ES ASID Space Limit Control

The SEV VMs using ASIDs below the SEV-ES ASID Space Limit must enable the SEVES feature. The valid values for this field are from 0x1 (1) to 0x10 (16). Default is 1. Options include **Auto** and Manual.

► CPU Information

These sections are for informational purposes. They will display some details about the detected CPUs on the motherboard, such as:

- CPU Version
- Number of Cores Running
- Processor Family
- Processor Model
- Processor Stepping
- Microcode Patch Level
- L1 Instruction Cache (Size/Method)
- L1 Data Cache (Size/Method)
- L2 Data Cache (Size/Method)
- L3 Cache per Socket (Size/Method)

► NB Configuration

Determinism Control

Use this setting to configure the Determinism Control. Options include Manual and **Auto**.

cTDP Control

Use this setting to configure the cTDP Control. Options include Manual and **Auto**.

IOMMU

Use this setting to enable or disable IOMMU. Options include **Disabled**, Enabled, and Auto.

ACS Enable

Use this setting to enable or disable ACS. Options include Enabled, Disabled and **Auto**.

Package Power Limit Control

Use this setting for Package Power Limit Control. Options include Manual and **Auto**.

APBDIS

Use this setting to set APBDIS. Options include 0, 1 and **Auto**.

DF Cstates

Use this setting to enable or disable DF Cstates. Options include Disabled, Enabled, and **Auto**.

Preferred IO

Use this setting for Preferred IO. Options include Manual and **Auto**.

► Memory Configuration

Memory Clock

This setting allows you to select different memory clock speed. The options are **Auto**, 2666MT/s, 2933MT/s and 3200MT/s.

Memory Interleaving

This setting controls fabric level memory interleaving. Note that the channel, die and socket have requirements on memory populations and it will be ignored if the memory doesn't support the selected option. The options are Disabled and **Auto**.

Memory Interleaving size

This setting controls the memory interleaving size. This determines the starting address of the interleave (bit 8, 9, 10 or 11). The options are 256 Bytes, 512 Bytes, 1 KB, 2 KB and **Auto**.

Chipselect Interleaving

This setting controls interleave memory blocks across the DRAM chip for node 0. The options are Disabled and **Auto**.

BankGroupSwap

This setting controls the Bank Group Swap. The options are Enabled, Disabled and **Auto**.

DRAM Scrub Time

This setting provides a value that is the number of hours to scrub memory. The options are Disabled, 1 hour, 4 hours, 8 hours, 16 hours, 24 hours, 48 hours and **Auto**.

► CPU1 Memory Configuration

These sections are for informational purposes. They will display some details about the detected memory according to each CPU on the motherboard, such as:

- Detected Size (per slot, in MB)
- Current Speed (MT/s)

► PCIe/PCI/PnP Configuration

This menu provides PCIe/PCI/PnP configuration settings and information.

PCI Bus Driver Version

PCI Devices Common Settings:

Above 4G Decoding

This setting Disables or **Enables** 64-bit capable devices ability to be decoded in above 4G address space (only if the system supports 64-bit PCI decoding).

SR-IOV Support

If the system has SR-IOV capable PCIe devices, this setting will **Disable** or Enable the Single Root IO Virtualization Support for the system.

BME DMA Mitigation

Re-enable Bus Master Attribute is disabled during Pci enumeration for PCI Bridges after SMM Locked. The options are **Disabled** and Enabled.

PCIe Spread Spectrum

Use this setting to enable or disable PCIe Spread Spectrum for your system. The options are Enabled and **Disabled**.

PCIe ARI Support

Use this setting to control the Alternative Routing-ID Interpretation. The options are Disable, Enable and **Auto**.

VGA Priority

Use this setting to select between onboard or offboard VGA support. The options are **Onboard** and Offboard.

NVMe Firmware Source

Use this setting to select between the AMI Native firmware support or the device vendor-defined firmware support. The options are **Vendor Defined Firmware** and AMI Native Support.

M.2 (AHCI) Firmware Source

The options are **Vendor Defined Firmware** and AMI Native Support.

Maximum Read Request

Use this setting to set maximum read request size of PCI Express device or allow system BIOS to select the value. The options are **Auto**, 128 Bytes, 256 Bytes, 512 Bytes, 1024 Bytes, 2048 Bytes, and 4096 Bytes.

PCI Devices Option Rom Setting

Onboard NVME 0 OPROM

Use this setting to enable or disable the Onboard NVME OPROM function. The options include Disabled and **EFI**.

Onboard NVME 1 OPROM

Use this setting to enable or disable the Onboard NVME OPROM function. The options include Disabled and **EFI**.

Onboard NVME 2 OPROM

Use this setting to enable or disable the Onboard NVME OPROM function. The options include Disabled and **EFI**.

Onboard NVME 3 OPROM

Use this setting to enable or disable the Onboard NVME OPROM function. The options include Disabled and **EFI**.

CPU1 SLOT 1 PCIe 4.0 x16 OPROM

This setting enables or disables the listed PCI/PCIX/PCIe Slot OPROM option. The options include Disabled and **EFI**.

CPU1 SLOT 2 PCIe 4.0 x16 OPROM

This setting enables or disables the listed PCI/PCIX/PCIe Slot OPROM option. The options include Disabled and **EFI**.

CPU1 SLOT 3 PCIe 4.0 x16 OPROM

This setting enables or disables the listed PCI/PCIX/PCIe Slot OPROM option. The options include Disabled and **EFI**.

CPU1 SLOT 5 PCIe 4.0 x16 OPROM

This setting enables or disables the listed PCI/PCIX/PCIe Slot OPROM option. The options include Disabled and **EFI**.

CPU1 SLOT 6 PCIe 4.0 x16 OPROM

This setting enables or disables the listed PCI/PCIX/PCIe Slot OPROM option. The options include Disabled and **EFI**.

CPU1 SLOT 7 PCIe 4.0 x16 OPROM

This setting enables or disables the listed PCI/PCIX/PCIe Slot OPROM option. The options include Disabled and **EFI**.

Onboard 10G LAN Enable

This setting enables or disables onboard 10G LAN. The options include Disabled and **Enabled**.

Onboard LAN1 OPROM

This setting enables or disables the onboard LAN 1 Option ROM. The options include Disabled and **EFI**.

Onboard LAN 2 OPROM

This setting enables or disables the onboard LAN 2 Option ROM. The options include Disabled and **EFI**.

► Network Stack Configuration**Network Stack**

This setting allows you to enable or disable the UEFI Network Stack. The options are Disabled and **Enabled**.

IPv4 PXE Support

This setting allows you to enable or disable IPv4 PXE boot support. If disabled, IPv4 PXE boot support will not be available. The options are Disabled and **Enabled**.

IPv4 HTTP Support

This setting allows you to enable or disable IPv4 HTTP boot support. If disabled, IPv4 HTTP boot support will not be available. The options are **Disabled** and Enabled.

IPv6 PXE Support

This setting allows you to enable or disable IPv6 PXE boot support. If disabled, IPv6 PXE boot support will not be available. The options are Disabled and **Enabled**.

IPv6 HTTP Support

This setting allows you to enable or disable IPv6 HTTP boot support. If disabled, IPv6 HTTP boot support will not be available. The options are **Disabled** and Enabled.

PXE boot wait time

This setting allows you to set in a number field the wait time to press <ESC> to abort the PXE boot. The default value is **0**.

Media detect count

This setting allows you set in a number field the number of times presence of media will be checked. The default value is **1**.

►USB Configuration**USB Module Version****USB Devices****Legacy Support**

Select Enabled to support onboard legacy USB devices. Select Auto to disable legacy support if there are no legacy USB devices present. Select Disable to have all USB devices available for EFI applications only. The options include **Enabled**, Disabled and Auto.

XHCI Hand-off

This is a work-around solution for operating systems that do not support XHCI (Extensible Host Controller Interface) hand-off. The XHCI ownership change should be claimed by the XHCI driver. The options include **Enabled** and Disabled.

Port 60/64 Emulation

Select Enabled for I/O port 60h/64h emulation support, which in turn, will provide complete legacy USB keyboard support for the operating systems that do not support legacy USB devices. The options include Disabled and **Enabled**.

► Serial Port Console Redirection

COM1

Console Redirection

Select Enabled to enable console redirection support for a serial port specified by the user. The options are **Disabled** and Enabled.

**If the item above set to Enabled, the following items will become available for user's configuration:*

► Console Redirection Settings

Terminal Type

This feature allows the user to select the target terminal emulation type for Console Redirection. Select VT100 to use the ASCII Character set. Select VT100+ to add color and function key support. Select ANSI to use the Extended ASCII Character Set. Select VT-UTF8 to use UTF8 encoding to map Unicode characters into one or more bytes. The options are VT100, **VT100+**, VT-UTF8, and ANSI.

Bits per second

Use this feature to set the transmission speed for a serial port used in Console Redirection. Make sure that the same speed is used in the host computer and the client computer. A lower transmission speed may be required for long and busy lines. The options are 9600, 19200, 38400, 57600 and **115200** (bits per second).

Data Bits

Use this feature to set the data transmission size for Console Redirection. The options are 7 and **8**.

Parity

A parity bit can be sent along with regular data bits to detect data transmission errors. Select Even if the parity bit is set to 0, and the number of 1's in data bits is even. Select Odd if the parity bit is set to 0, and the number of 1's in data bits is odd. Select None if you do not want to send a parity bit with your data bits in transmission. Select Mark to add a mark as a parity bit to be sent along with the data bits. Select Space to add a Space as a parity bit to be sent with your data bits. The options are **None**, Even, Odd, Mark, and Space.

Stop Bits

A stop bit indicates the end of a serial data packet. Select 1 Stop Bit for standard serial data communication. Select 2 Stop Bits if slower devices are used. The options are **1** and 2.

Flow Control

Use this feature to set the flow control for Console Redirection to prevent data loss caused by buffer overflow. Send a "Stop" signal to stop sending data when the receiving buffer is full. Send a "Start" signal to start sending data when the receiving buffer is empty. The options are **None** and Hardware RTS/CTS.

VT-UTF8 Combo Key Support

Select Enabled to enable VT-UTF8 Combination Key support for ANSI/VT100 terminals. The options are Disabled and **Enabled**.

Recorder Mode

Select Enabled to capture the data displayed on a terminal and send it as text messages to a remote server. The options are **Disabled** and Enabled.

Resolution 100x31

Select Enabled for extended-terminal resolution support. The options are Disabled and **Enabled**.

Putty KeyPad

This feature selects the settings for Function Keys and KeyPad used for Putty, which is a terminal emulator designed for the Windows OS. The options are **VT100**, LINUX, XTERMR6, SC0, ESCN, and VT400.

SOL

Console Redirection

Select Enabled to enable SOL console redirection support for a serial port specified by the user. The options are **Enabled** and Disabled.

****If the item above is set to Enabled, the following items will become available for user's configuration:***

► Console Redirection Settings

Terminal Type

This feature allows the user to select the target terminal emulation type for Console Redirection. Select VT100 to use the ASCII Character set. Select VT100+ to add color and function key support. Select ANSI to use the Extended ASCII Character Set. Select VT-UTF8 to use UTF8 encoding to map Unicode characters into one or more bytes. The options are VT100, **VT100+**, VT-UTF8, and ANSI.

Bits per second

Use this feature to set the transmission speed for a serial port used in Console Redirection. Make sure that the same speed is used in the host computer and the client computer. A lower transmission speed may be required for long and busy lines. The options are 9600, 19200, 38400, 57600 and **115200** (bits per second).

Data Bits

Use this feature to set the data transmission size for Console Redirection. The options are 7 and **8**.

Parity

A parity bit can be sent along with regular data bits to detect data transmission errors. Select Even if the parity bit is set to 0, and the number of 1's in data bits is even. Select Odd if the parity bit is set to 0, and the number of 1's in data bits is odd. Select None if you do not want to send a parity bit with your data bits in transmission. Select Mark to add a mark as a parity bit to be sent along with the data bits. Select Space to add a Space as a parity bit to be sent with your data bits. The options are **None**, Even, Odd, Mark, and Space.

Stop Bits

A stop bit indicates the end of a serial data packet. Select 1 Stop Bit for standard serial data communication. Select 2 Stop Bits if slower devices are used. The options are **1** and 2.

Flow Control

Use this feature to set the flow control for Console Redirection to prevent data loss caused by buffer overflow. Send a "Stop" signal to stop sending data when the receiving buffer is full. Send a "Start" signal to start sending data when the receiving buffer is empty. The options are **None** and Hardware RTS/CTS.

VT-UTF8 Combo Key Support

Select Enabled to enable VT-UTF8 Combination Key support for ANSI/VT100 terminals. The options are Disabled and **Enabled**.

Recorder Mode

Select Enabled to capture the data displayed on a terminal and send it as text messages to a remote server. The options are **Disabled** and Enabled.

Resolution 100x31

Select Enabled for extended-terminal resolution support. The options are Disabled and **Enabled**.

Legacy Console Redirection Resolution

For Legacy OS systems, use this setting to specify the number of Rows and Columns supported for redirection. The options are 80x24 and **80x25**.

Putty KeyPad

This feature selects the settings for Function Keys and KeyPad used for Putty, which is a terminal emulator designed for the Windows OS. The options are **VT100**, LINUX, XTERMR6, SC0, ESCN, and VT400.

Redirection After BIOS POST

For this setting, when the Bootloader is selected, then the Legacy Console Redirection is disabled before booting to the legacy OS. If you select Always Enable, then the Legacy Console Redirection is enabled for legacy OS systems. The options are **Always Enable** and BootLoader.

Legacy Console Redirection

Legacy Serial Redirection Port

For this setting, select a COM port to display redirection of Legacy OS and Legacy OPROM messages. Options include **COM1**.

Serial Port for Out-of-Band Management/Windows Emergency Management Services (EMS)

Console Redirection

Select Enabled to enable EMS console redirection support for a serial port specified by the user. The options are **Enabled** and Disabled.

****If the item above is set to Enabled, the following items will become available for user's configuration:***

► Console Redirection Settings

Out-of-Band Mgmt Port

The feature selects a serial port in a client server to be used by the Microsoft Windows Emergency Management Services (EMS) to communicate with a remote host server. The options are **COM1** and AMT SOL.

Terminal Type

Use this feature to select the target terminal emulation type for Console Redirection. Select VT100 to use the ASCII character set. Select VT100+ to add color and function key support. Select ANSI to use the extended ASCII character set. Select VT-UTF8 to use UTF8 encoding to map Unicode characters into one or more bytes. The options are VT100, VT100+, **VT-UTF8**, and ANSI.

Bits per Second

This item sets the transmission speed for a serial port used in Console Redirection. Make sure that the same speed is used in the host computer and the client computer. A lower transmission speed may be required for long and busy lines. The options are 9600, 19200, 57600, and **115200** (bits per second).

Flow Control

Use this item to set the flow control for Console Redirection to prevent data loss caused by buffer overflow. Send a "Stop" signal to stop sending data when the receiving buffer is full. Send a "Start" signal to start sending data when the receiving buffer is empty. The options are **None**, Hardware RTS/CTS, and Software Xon/Xoff.

Data Bits EMS**Parity EMS****Stop Bits EMS****► Network Configuration**

(Available when EFI is selected in LAN OPROM after reboot)

► VLAN Configuration (MAC: 3CECEF741952)**► Enter Configuration Menu****Create New VLAN****VLAN ID**

This option is an input field used to enter a unique numeric VLAN ID. The valid range is from 0~4096.

Priority

This option is an input field used to enter a unique numeric VLAN 802.1Q priority. The valid range is from 0~7.

Add VLAN

Use this option to create a new VLAN or update an existing VLAN.

Configured VLAN List**Remove VLAN**

Use this option to remove an existing VLAN.

► IPv4 Network Configuration

Configured

Select Enabled to activate IPv4 network configuration. The options include **Disabled** and Enabled.

****If the item above is set to Enabled, the following item will become available for configuration:***

Enable DHCP

This feature allows the user to select the source of the IP address for this computer. If Disabled is selected, you will need to know the local IP address of this computer and enter it to the system manually in the field. If Enabled is selected, the system will search for a DHCP (Dynamic Host Configuration Protocol) server in the network that it is attached to and request the next available IP address for this computer. The options include **Disabled** and Enabled.

****If the item above is set to Disabled, the following items will become available for configuration:***

Local IP Address

This item sets and displays the Local IP address for this computer. This should be in decimal and in dotted quad form.

Local NetMask

This item sets the sub-network that this computer belongs to. The value of each three-digit number separated by dots should not exceed 255.

Local Gateway

This item sets the Gateway IP address for this computer. This should be in decimal and in dotted quad form (i.e., 172.31.0.1).

Local DNS Servers

This item sets the address for the local DNS servers for this computer. This should be in decimal and in dotted quad form (i.e., 172.31.0.1).

Save Changes and Exit

Use this item to save the changes above and exit.

► IPv6 Network Configuration

► Enter Configuration Menu

Enable DHCP

Interface ID

The 64 bit alternative interface ID for the device. .

DAD Transmit Count

The number of consecutive Neighbor Solicitation messages sent while performing Duplicate Address Detection on a tentative address. A value of zero indicates that Duplicate Address Detection is not performed. .

Policy

Options include **automatic** and manual.

Save Changes and Exit

Use this item to save the changes above and exit.

► **SATA Configuration**

This section displays the detected SATA devices installed on the system.

SATA Enable

This setting enables or disables the on chip SATA controller. The options are Disabled, Enabled, and **Auto**.

► **SATA Information**

This section displays information on the detected SATA devices.

► **KMIP Server Configuration**

KMIP Server IP address

Enter IP4 address in dotted-decimal notation.

KMIP TCP Port number

Enter KMIP TCP Port number 100 to 9999. The default value is **5696**.

TimeZone

Enter current timezone GMT+? The default value is GMT+8 Taiwan time.

Client UserName

Enter Client identity: user name, name length is 0 to 63 characters.

Client Password

Enter Client identity: password, password length is 0 to 31 characters.

KMS TLS Certificate

► **CA Certificate**

The options include **Update**, Delete, Export

► **Client Certificate**

The options include **Update**, Delete, Export

► **Client Private Key**

The options include **Update**, Delete, Export

► NVMe Configuration

NVMe Information

NVMe RAID mode

Use the setting to set the NVMe RAID mode. Options include **Disabled** and Enabled.

► NVMe Information

NVMe Configuration

► HTTP Boot Configuration

HTTP Boot Configuration

HTTP Boot Policy

Options include Apply to all LANs, **Apply to each LAN** and Boot Priority #1 instantly.

Priority of HTTP Boot

Instance of Priority 1

Rank targeted port

Select IPv4 or IPv6

Targeted LAN port is boot from IPv4 or IPv6. Options include **IPv4** and IPv6t.

Boot Description

This item must be filled out, otherwise boot option for the URI will not be created. Length of description isn't more than 75.

Boot URI

A new IPv4/IPv6 Boot Option will be created according to this Boot URI. Only supported on Dual or EFI Mode. Length of URI isn't more than 128.

► Intel(R) I210 Gigabit Network Connection

PORT CONFIGURATION MENU

► NIC Configuration

Link Speed

Use the setting to specify the port speed used for the selected boot protocol. Options include **Auto Negotiated**, 10 Mbps Half, 10 Mbps Full, 100 Mbps Half, and 100 Mbps Full.

Wake On Lan

Use the setting to enable or disable the server to be powered on using an in-band magic packet. Option include Disabled and **Enabled**.

Blink LEDs

Use the setting to identify the physical network port by blinking the associated LED.

PORT CONFIGURATION INFORMATION

UEFI Driver

This item displays the UEFI Driver model.

Adapter PBA

This item displays the Adapter PBA.

Chip Type

This item displays the Chip Type.

PCI Device ID

This item displays the PCI Device ID.

PCI Address

This item displays the PCI Address.

Link Status

This item displays Link Status.

MAC Address

This item displays the MAC Address.

Virtual MAC Address

This option displays the programmatically assignable MAC address for port.

▶ TLS Authentication Configuration

This submenu allows the user to configure Transport Layer Security (TLS) settings.

▶ Server CA Configuration

This feature allows the user to configure the client certificate that is to be used by the server.

▶ Enroll Certification

This feature allows the user to enroll the certificate in the system.

▶ Enroll Certification Using File

Use this feature to enroll certification from a file.

Certification GUID

Use this feature to enroll to input the certification GUID.

▶ Commit Changes and Exit

Use this feature to save all changes and exit TLS settings.

▶ Discard Changes and Exit

Use this feature to enroll to discard all changes and exit TLS settings.

▶ Delete Certification

Use this feature to delete certification.

▶ iSCSI Configuration

iSCSI Initiator Name

This feature allows the user to enter the unique name of the iSCSI Initiator in IQN format. Once the name of the iSCSI Initiator is entered into the system, configure the proper settings for the following items.

▶ Add an Attempt

Use this setting to add an attempt.

▶ Delete Attempts

Use this setting to delete one or more attempts.

▶ Change Attempt Order

Use this setting to change the order of attempts.

▶ Driver Health

▶ Intel (R) PR0/1000 6.1.16 PCIe Healthy

This item displays the information/status of driver installed in the system.

4.4 IPMI

Use this feature to configure Intelligent Platform Management Interface (IPMI) settings.

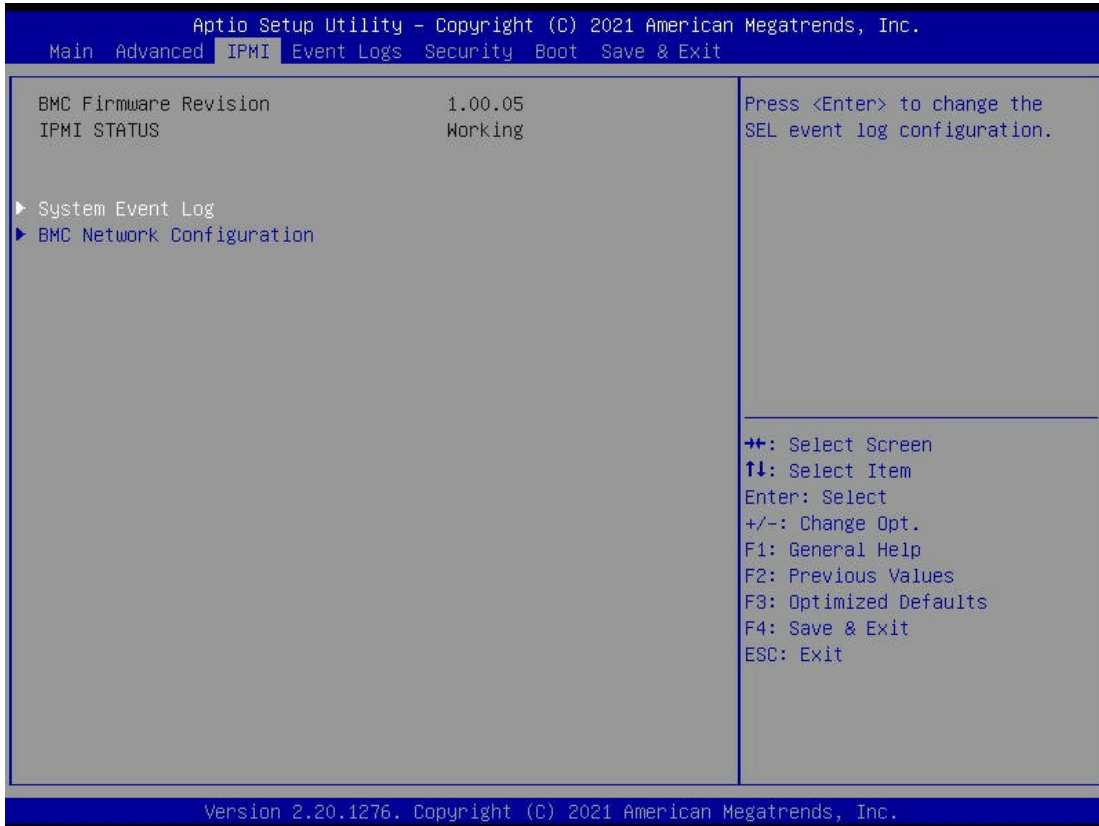

▶ System Event Log

SEL Components

Select Enabled for all system event logging at bootup. The options include Disabled and Enabled.

Erasing Settings

Erase SEL

Select Yes, On next reset to erase all system event logs upon next system reboot. Select Yes, On every reset to erase all system event logs upon each system reboot. Select No to keep all system event logs after each system reboot. The options include **No**, Yes, On next reset, and Yes, On every reset.

When SEL is Full

This feature allows the user to decide what the BIOS should do when the system event log is full. Select Erase Immediately to erase all events in the log when the system event log is full. The options include **Do Nothing** and Erase Immediately.

► BMC Network Configuration

Update IPMI LAN Configuration

Select Yes for the BIOS to implement all IP/MAC address changes at the next system boot. The options include **No** and Yes.

****If the item above is set to Yes, the following item will become available for user's configuration:***

Configuration Address Source

This feature allows the user to select the source of the IP address for this computer. If Static is selected, you will need to know the IP address of this computer and enter it to the system manually in the field. If DHCP is selected, the BIOS will search for a DHCP (Dynamic Host Configuration Protocol) server in the network that is attached to and request the next available IP address for this computer. The options include Static and **DHCP**.

VLAN

This item configures the virtual LAN settings. The options include **Disabled** and Enabled.

IPv6 Support

Use this feature to enable IPv6 support. The options include Enabled and **Disabled**.

4.5 Event Logs

Use this feature to configure Event Log settings.

Note: After you've made a change on a setting below, please be sure to reboot the system for the change to take effect.



▶ Change SMBIOS Event Log Settings

Enabling/Disabling Options

SMBIOS Event Log

Select Enabled to enable SMBIOS (System Management BIOS) Event Logging during system boot. The options are Disabled and **Enabled**.

Erasing Settings

Erase Event Log

The options are **No**, Yes, Next reset, and Yes, Every reset.

Select No to keep the event log without erasing it upon next system bootup. Select Yes, Next Reset to erase the event log upon next system reboot. The options are **No**, Yes, Next reset, and Yes, Every reset.

When Log is Full

Select Erase Immediately to immediately erase all errors in the SMBIOS event log when the event log is full. Select Do Nothing for the system to do nothing when the SMBIOS event log is full. The options are **Do Nothing** and Erase Immediately.

SMBIOS Event Log Standard Settings

Log System Boot Event

Select Enabled to log system boot events. The options are Enabled and **Disabled**.

MECI (Multiple Event Count Increment)

Enter the increment value for the multiple event counter. Enter a number between 1 to 255. The default setting is **1**.

METW (Multiple Event Count Time Window)

This feature is used to determine how long (in minutes) should the multiple event counter wait before generating a new event log. Enter a number between 0 to 99. The default setting is **60**.

4.6 Security Settings

This menu allows the user to configure the following security settings for the system.

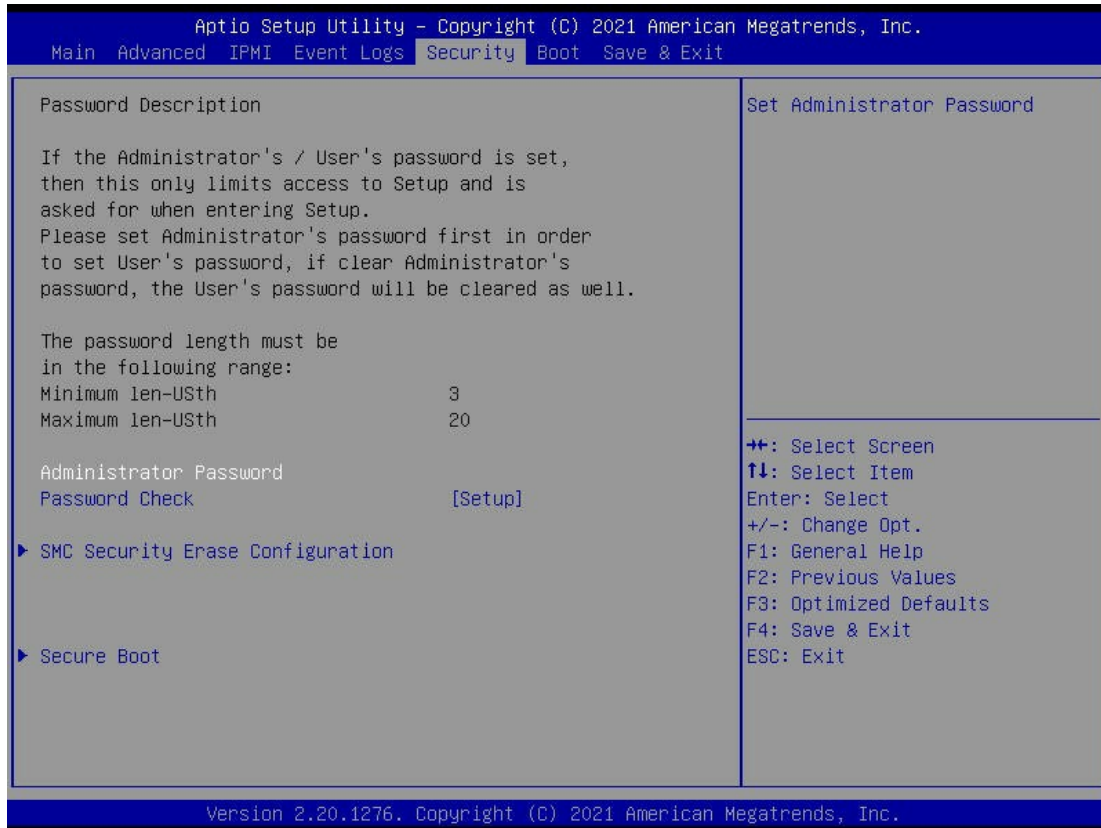

Administrator Password

Use this feature to set the administrator password which is required to enter the BIOS setup utility. The length of the password should be from 3 characters to 20 characters long.

Password Check

Select Setup for the system to check for a password at Setup. Select Always for the system to check for a password at system boot and upon entering the BIOS Setup utility. The options are **Setup** and **Always**.

▶ SMC Security Erase Configuration

▶ Secure Boot

When you select this submenu and press the <Enter> key, the following items will display:

System Mode

Secure Boot

Select Enabled to use Secure Boot settings. The options are Disabled and **Enabled**.

Secure Boot Mode

Use this feature to select the desired secure boot mode for the system. The options are **Standard** and Custom.

****If the item above is set to Custom, the following items become available for configuration:***

▶ Restore Factory Keys

Select Yes to restore manufacturer default keys used to ensure system security. The options are **Yes** and No.

▶ Reset to Setup Mode

Select Yes to reset the system to the Setup Mode. The options are **Yes** and No.

▶ Key Management

Factory Key Provision

The options are Disabled and **Enabled**.

▶ Restore Factory defaults

Select Yes to restore database variables to the manufacturer default settings. The options are **Yes** and No.

▶ Reset To Setup Mode

Select Yes to delete all Secure Boot key databases and force the system to Setup Mode. The options are Yes and No.

▶ Export Secure Boot Variables

Use this feature to copy the NVRAM contents of the secure boot variables to a file.

▶ Enroll Efi Image

This feature allows the image to run in Secure Boot mode.

Device Guard Ready

▶ Remove 'UEFI CA' from DB

Use this feature to remove the Microsoft UEFI CA certificate from the database. The options are Yes and No.

► Restore DB defaults

Select Yes to restore all DBs to the default settings. The options are Yes and No.

Secure Boot variable | Size | Keys# | Key Source**► Platform Key (PK)**

This feature allows the user to enter and configure a set of values to be used as platform firmware keys for the system. The sizes, keys numbers, and key sources of the platform keys will be indicated as well. Select Update to update the platform key.

► Key Exchange Keys

This feature allows the user to enter and configure a set of values to be used as Key-Exchange-Keys for the system. The sizes, keys numbers, and key sources of the Key-Exchange-Keys will be indicated as well. Select Update to update your "Key Exchange Keys". Select Append to append your "Key Exchange Keys".

► Authorized Signatures

This feature allows the user to enter and configure a set of values to be used as Authorized Signatures for the system. These values also indicate the sizes, keys numbers, and the sources of the authorized signatures. Select Update to update your "Authorized Signatures". Select Append to append your "Authorized Signatures". The settings are **Details**, Export, Update, Append and Delete.

► Forbidden Signatures

This feature allows the user to enter and configure a set of values to be used as Forbidden Signatures for the system. These values also indicate sizes, keys numbers, and key sources of the forbidden signatures. Select Update to update your "Forbidden Signatures". Select Append to append your "Forbidden Signatures". The settings are **Details**, Export, Update, Append and Delete.

► Authorized TimeStamps

This feature allows the user to set and save the timestamps for the authorized signatures which will indicate the time when these signatures are entered into the system. Select Update to update your "Authorized TimeStamps". Select Append to append your "Authorized TimeStamps". The settings are **Update**, and Append.

► Os Recovery Signatures

This feature allows the user to set and save the authorized signatures used for OS recovery. Select Update to update your "OS Recovery Signatures". Select Append to append your "OS Recovery Signatures". The settings are **Update**, and Append.

4.7 Boot Settings

Use this feature to configure Boot Settings:

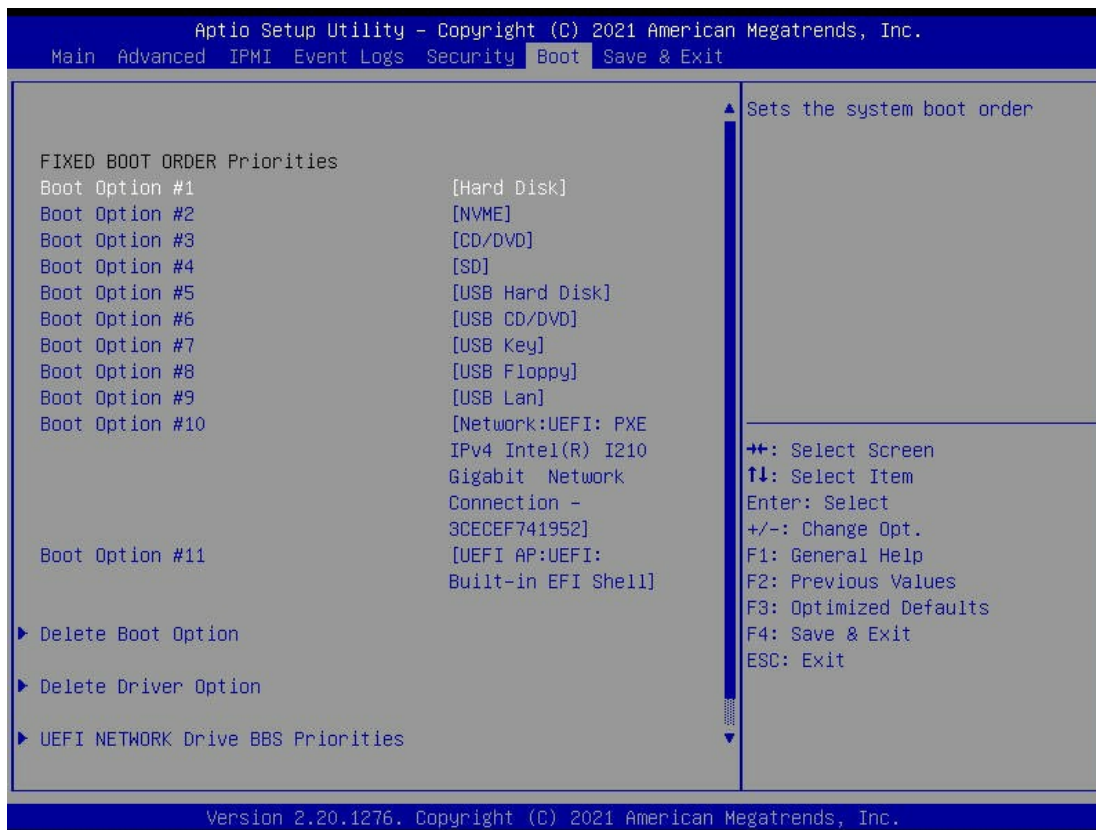

FIXED BOOT ORDER Priorities

This feature prioritizes the order of a bootable device from which the system will boot. Press the <Enter> key on each item sequentially to select devices.

- Boot Option #1
- Boot Option #2
- Boot Option #3
- Boot Option #4
- Boot Option #5
- Boot Option #6

- Boot Option #7
- Boot Option #8
- Boot Option #9
- Boot Option #10
- Boot Option #11

▶ **Delete Boot Option**

Use this feature to select a boot device to delete from the boot priority list.

Delete Boot Option

Use this feature to remove an EFI boot option from the boot priority list.

▶ **Delete Driver Option**

Use this feature to remove an EFI Driver option from the drive order.

Delete Driver Option

Use this feature to remove an EFI boot option from the boot priority list.

▶ **UEFI NETWORK Drive BBS Priorities**

Use this feature to set the system boot order.

▶ **UEFI Application Boot Priorities**

Use this feature to specify the Boot Device Priority sequence from available UEFI Application.

4.8 Save & Exit

Select the Save & Exit menu from the BIOS setup screen to configure the settings below.

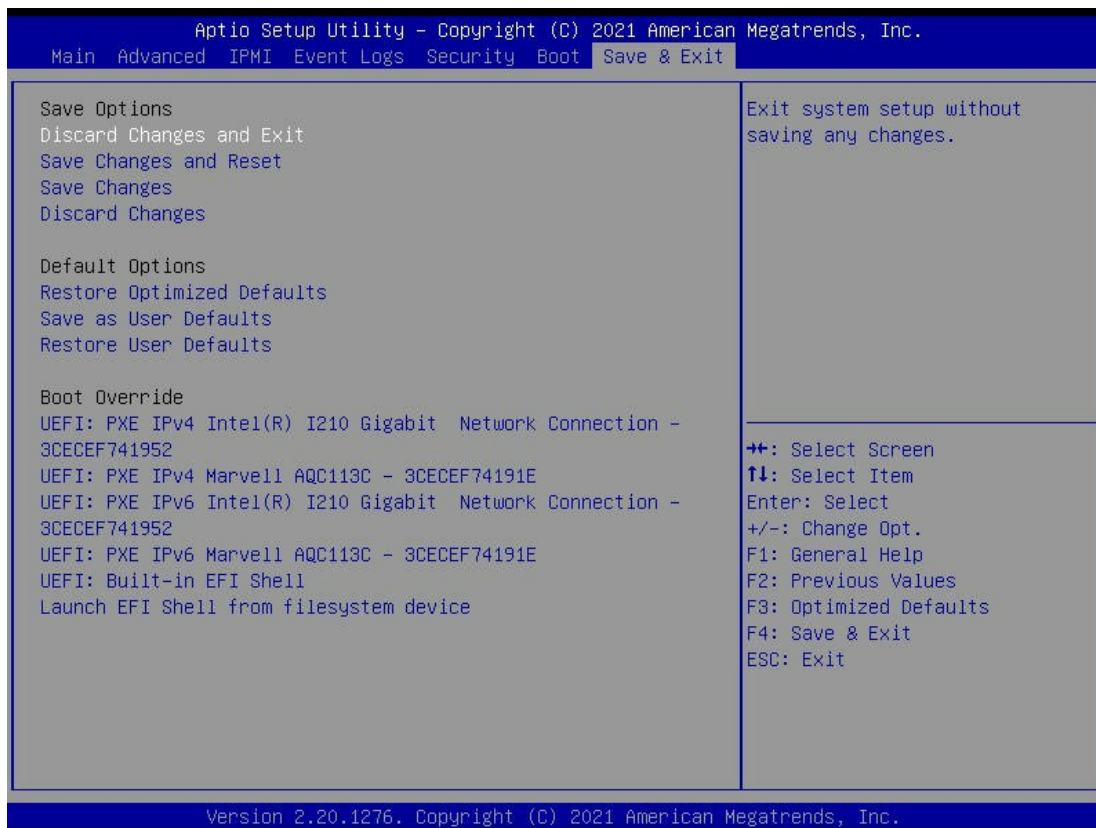

Save Options

Discard Changes and Exit

Select this option to exit from the BIOS setup utility without making any permanent changes to the system configuration and reboot the computer.

Save Changes and Reset

When you have completed the system configuration changes, select this option to leave the BIOS setup utility and reboot the computer for the new system configuration parameters to become effective.

Save Changes

When you have completed the system configuration changes, select this option to save all changes made. This will not reset (reboot) the system.

Discard Changes

Select this option and press the <Enter> key to discard all the changes you've made and return to the AMI BIOS setup utility.

Default Options**Restore Optimized Defaults**

To set this feature, select Restore Defaults from the Exit menu and press the <Enter> key to load manufacturer default settings which are intended for maximum system performance but not for maximum stability.

Save as User Defaults

To set this feature, select Save as User Defaults from the Exit menu and press the <Enter> key. This enables the user to save all changes to the BIOS setup for future use.

Restore User Defaults

To set this feature, select Restore User Defaults from the Exit menu and press the <Enter> key. Use this feature to retrieve user-defined default settings that were saved previously.

Boot Override

This feature allows the user to override the Boot priorities sequence in the Boot menu, and immediately boot the system with a device specified by the user instead of the one specified in the boot list. This is a one-time override.

Launch EFI Shell from filesystem device

This feature attempts to launch EFI Shell application (Shell.efi) from one of the available file system devices.

Appendix A

Software

After the hardware has been installed, you can install the Operating System (OS), configure RAID settings and install the drivers. Note that RAID settings are only available on these operating systems: Microsoft Windows 10 and Red Hat Linux.

A.1 Microsoft Windows OS Installation

If you will be using RAID, you must configure RAID settings before installing the Windows OS and the RAID driver. Refer to the RAID Configuration User Guides posted on our website at www.supermicro.com/support/manuals.

Installing the AMD-RAID Drivers during a Windows OS Installation

1. Create a method to access the MS Windows installation ISO file. That might be a DVD, perhaps using an external USB/SATA DVD drive, or a USB flash drive, or the IPMI KVM console.
2. Boot the system and allow it to access the Microsoft Windows operating system CD-ROM or DVD.
3. In the Windows setup window, select the language, time and keyboard options.
4. Select **Next**, and select **Install Now**.
5. If prompted, select the desired operating system, and then select **Next**.
6. Insert the device with the AMD-RAID drivers, select **Browse**, navigate to the directory containing the saved AMD-RAID drivers and select **OK**.

Note: If the installation has multiple controllers, there will be two or more `rcbottom.inf`'s listed.

7. Select the first **AMD-RAID Bottom Device (rcbottom.inf) driver** in the list and select **Next**.
8. Select **OK** in the Load Driver Warning message:
9. At the Select the Driver window, select **Browse** to navigate to the directory containing the saved AMD-RAID drivers, and select **OK**.
10. Select the **AMD-RAID Controller (rcraid.inf) driver** in the list, and select **Next**.

11. Select **(Check Mark) I Accept the License Terms**, and select **Next**.
12. Select **Custom: Install Windows Only (advanced)**. Once both drivers have been loaded, a valid Virtual Disk appears. Select Load Drivers.
13. Select **Browse** to navigate to the directory containing the saved AMD-RAID drivers, and select **OK**.
14. Select the **AMD-RAID Config Device (rccfg.inf) driver** from the list and select **Next**.
15. In the Where do you want to install Windows window, select **Next**.
16. Follow the on-screen instructions to complete the installation of the Windows operating system.
17. After the OS is installed, open Device Manager and verify the following:
 - Expand Storage Controllers: there is an entry listed as **AMD-RAID Bottom Device**.
 - Expand Storage Controllers: there is an entry listed as **AMD-RAID Controller**.
 - Expand System Devices: there is an entry listed as **AMD-RAID Config Device**.
18. Remove the storage medium and Microsoft Windows OS CD-ROM or DVD from the applicable drive(s) or port.

A.2 Red Hat Linux OS Installation

Installing the AMD-RAID Drivers during a Red Hat Linux Installation

Note: When installing Red Hat Linux, use the Linux dd installation mode instead of the Linux expert mode.

1. Create a method to access the Red Hat Linux installation ISO file. That might be a DVD, perhaps using an external USB/SATA DVD drive, or a USB flash drive, or the IPMI KVM console.
2. Boot the system and allow it to access the Red Hat Linux operating system CD-ROM or DVD.
3. At the Red Hat Enterprise Linux Welcome window, press the **<Up>** arrow key, select Install Red Hat Enterprise Linux 8.x, and press the **<E>** key.
4. Press the **<Down>** arrow key twice, select the **linuxefi /images** string, and press the **<END>** key.

5. Add “**inst.dd modprobe.blacklist=ahci modprobe.blacklist=nvme**” to the end of the string, and press **<Ctrl> <X>**.
 - (Example) linuxefi /images.....quiet inst.dd modprobe.blacklist=ahci modprobe.blacklist=nvme
- Note:** If the shell does not appear (the screen is black), reset and try with the settings below.
6. Add “**inst.dd modprobe.blacklist=ahci modprobe.blacklist=nvme nomodeset**” to the end of the string, and press **<Ctrl> <X>**.
 - (Example) linuxefi /images.....quiet inst.dd modprobe.blacklist=ahci modprobe.blacklist=nvme nomodeset
7. In the Driver Disk Device Selection, insert the USB drive (which contains the AMD-RAID dd-rcraid....x86_64.iso) into the USB port.
 - Press the **<r>** key, and press **<Enter>** to refresh.
 - Press the number key **<2>**, the number of the USB flash drive inserted above, and press **<Enter>**.
8. In the Choose Driver Disk ISO file, press the number key **<1>** (the number of the dd-rcraid-RHEL....el8.x86_64.iso entry), and press **<Enter>**.
9. In the Select Drivers to Install, press the number key **<1>** (the number of the /media/DD/.....x86_64.rpm entry), and press **<Enter>**.
10. The /media/DD/... is now selected and should look like [X] /media/DD/.....x86_64.rpm. Press the **<C>** key and press **<Enter>**.
11. In the Driver Disk Device Selection, press the **<C>** key, press **<Enter>** key, and remove the USB flash drive.
12. In the Welcome to Red Hat Enterprise Linux Screen, select the desired Language, select the desired Country, and click **Continue** in the bottom right corner.
13. At the Installation Summary Screen, configure the following:
 - Under Localization, select these items to review the settings and make any necessary changes:
 - **Keyboard**
 - **Language Support**
 - **Time and Date**

- Under Software, select **Software Selection**.
 - Under Base Environments, select **Server with GUI**, and click **Done** in the upper left corner.
 - Under System, select **Installation Destination**.
 - Under Local Standard Disks, select **AMD-RAID Array 01**.
 - Under Storage Configuration, select **Custom**, click **Done** in the upper left corner, and click the **Click here to create them automatically** link.
 - Under Installation:
 - Select **DATA/home**, change File System from xfs to **ext4**, select **SYSTEM/rhel-root**, change File System from xfs to **ext4**, select **SYSTEM/boot**, change File System from xfs to **ext4**, and click **Done** in the upper left corner.
 - In the Summary of Changes window, click **Accept Changes**.
 - Under Network and Hostname:
 - In the bottom left corner, enter a valid Hostname, and click the **Apply** button.
 - Select an Ethernet Port, and click **Configure** in the bottom right corner.
 - Enter valid entries, and click **Save**.
 - Under Ethernet, click the **ON** button and click **Done** In the upper left corner.
14. Click **Beginning Installation** in the bottom right corner.
15. In the Configuration Window:
- Click **Root Password**, enter an applicable root password, re-enter the root password, and click **Done** in the upper left corner.
 - Click **User Creation**, enter a Full Name, a Username, enter an applicable password, re-enter the user password, and click **Done** in the upper right corner.
 - When the message “Red Hat Enterprise Linux is now successfully installed and ready for you to use! Go ahead and reboot to start using it!” appears, click **Reboot** in the bottom right corner, and remove the installation device.
16. In the Initial Setup Window, click **License Information** under Licensing, review the EULA, select **(Check Mark) I accept the License Agreement** and click **Done** in the upper left corner.

- Under System, configure Subscription Manager in the bottom right corner, and click **Finish Configuration**.
17. Login to the system, select a user, and enter a password.
 18. In the Welcome window, select the desired Language, and click **Next**.
 19. In Typing Window, select the desired Language, and click **Next**.
 20. If desired, Configure Privacy, and click **Next**.
 21. In the Connect your Online Accounts, you can configure or click **Skip**.
 22. Click **Start using Red Hat Enterprise Linux Server**.

A.3 Driver Installation

The Supermicro website contains drivers and utilities for your system at <https://www.supermicro.com/wdl/>. Some of these must be installed, such as the chipset driver.

After accessing the website, go into the CDR_Images (in the parent directory of the above link) and locate the ISO file for your motherboard. Download this file to to a USB flash drive or a DVD. (You may also use a utility to extract the ISO file if preferred.)

Another option is to go to the Supermicro website at <http://www.supermicro.com/products/>. Find the product page for your motherboard, and "Download the Latest Drivers and Utilities". Insert the flash drive or disk and the screenshot shown below should appear.



Figure A-x. Driver & Tool Installation Screen

Note: Click the icons showing a hand writing on paper to view the readme files for each item. Click the computer icons to the right of these items to install each item (from top to the bottom) one at a time. **After installing each item, you must re-boot the system before moving on to the next item on the list.** The bottom icon with a CD on it allows you to view the entire contents.

A.4 SuperDoctor® 5

The Supermicro SuperDoctor 5 is a program that functions in a command-line or web-based interface for Windows and Linux operating systems. The program monitors such system health information as CPU temperature, system voltages, system power consumption, fan speed, and provides alerts via email or Simple Network Management Protocol (SNMP).

SuperDoctor 5 comes in local and remote management versions and can be used with Nagios to maximize your system monitoring needs. With SuperDoctor 5 Management Server (SSM Server), you can remotely control power on/off and reset chassis intrusion for multiple systems with SuperDoctor 5 or IPMI. SuperDoctor 5 Management Server monitors HTTP, FTP, and SMTP services to optimize the efficiency of your operation.

[SuperDoctor® Manual and Resources](#)

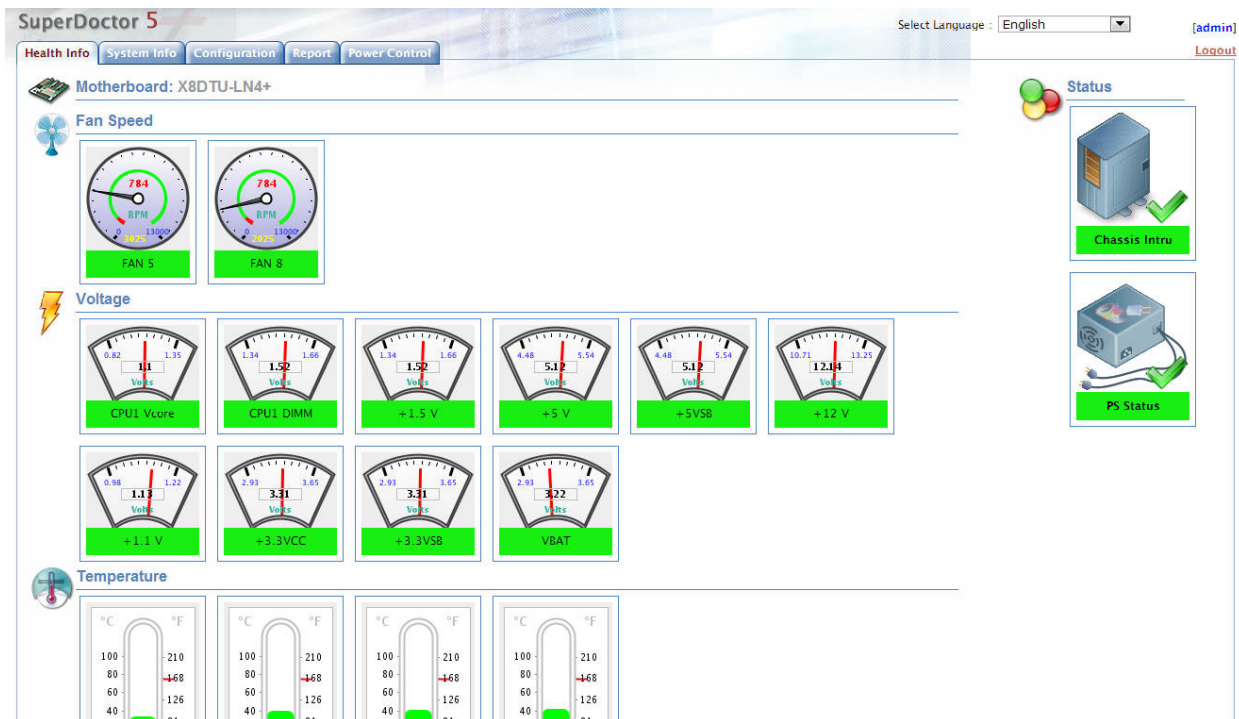

Figure A-x. SuperDoctor 5 Interface Display Screen (Health Information)

A.5 IPMI

The M12SWA-TF supports the Intelligent Platform Management Interface (IPMI). IPMI is used to provide remote access, monitoring and management. There are several BIOS settings that are related to IPMI.

Supermicro ships standard products with a unique password for the BMC ADMIN user. This password can be found on a label on the motherboard.

For general documentation and information on IPMI, please visit our website at: <http://www.supermicro.com/products/nfo/IPMI.cfm>.

Appendix B

Standardized Warning Statements

The following statements are industry standard warnings, provided to warn the user of situations which have the potential for bodily injury. Should you have questions or experience difficulty, contact Supermicro's Technical Support department for assistance. Only certified technicians should attempt to install or configure components.

Read this section in its entirety before installing or configuring components.

These warnings may also be found on our website at http://www.supermicro.com/about/policies/safety_information.cfm.

B.1 Battery Handling



Warning! There is the danger of explosion if the battery is replaced incorrectly. Replace the battery only with the same or equivalent type recommended by the manufacturer. Dispose of used batteries according to the manufacturer's instructions

電池の取り扱い

電池交換が正しく行われなかった場合、破裂の危険性があります。交換する電池はメーカーが推奨する型、または同等のものを使用下さい。使用済電池は製造元の指示に従って処分して下さい。

警告

電池更換不當會有爆炸危險。請只使用同類電池或制造商推薦的功能相當的電池更換原有電池。請按製造商的說明處理廢舊電池。

警告

電池更換不當會有爆炸危險。請使用製造商建議之相同或功能相當的電池更換原有電池。請按照製造商的說明指示處理廢棄舊電池。

Warnung

Bei Einsetzen einer falschen Batterie besteht Explosionsgefahr. Ersetzen Sie die Batterie nur durch den gleichen oder vom Hersteller empfohlenen Batterietyp. Entsorgen Sie die benutzten Batterien nach den Anweisungen des Herstellers.

Attention

Danger d'explosion si la pile n'est pas remplacée correctement. Ne la remplacer que par une pile de type semblable ou équivalent, recommandée par le fabricant. Jeter les piles usagées conformément aux instructions du fabricant.

¡Advertencia!

Existe peligro de explosión si la batería se reemplaza de manera incorrecta. Reemplazar la batería exclusivamente con el mismo tipo o el equivalente recomendado por el fabricante. Desechar las baterías gastadas según las instrucciones del fabricante.

אזהרה!

קיימת סכנת פיצוץ של הסוללה במידה והוחלפה בדרך לא תקינה. יש להחליף את הסוללה בסוג התואם מחברת יצרן מומלצת.

סילוק הסוללות המשומשות יש לבצע לפי הוראות היצרן.

هناك خطر من انفجار في حالة استبدال البطارية بطريقة غير صحيحة فعليك استبدال البطارية فقط بنفس النوع أو ما يعادلها كما أوصت به الشركة المصنعة تخلص من البطاريات المستعملة وفقا لتعليمات الشركة الصانعة

경고!

배터리가 올바르게 교체되지 않으면 폭발의 위험이 있습니다. 기존 배터리와 동일하거나 제조사에서 권장하는 동등한 종류의 배터리로만 교체해야 합니다. 제조사의 안내에 따라 사용된 배터리를 처리하여 주십시오.

Waarschuwing

Er is ontploffingsgevaar indien de batterij verkeerd vervangen wordt. Vervang de batterij slechts met hetzelfde of een equivalent type die door de fabrikant aanbevolen wordt. Gebruikte batterijen dienen overeenkomstig fabrieksvoorschriften afgevoerd te worden.

B.2 Product Disposal



Warning! Ultimate disposal of this product should be handled according to all national laws and regulations.

製品の廃棄

この製品を廃棄処分する場合、国の関係する全ての法律・条例に従い処理する必要があります。

警告

本产品的废弃处理应根据所有国家的法律和规章进行。

警告

本產品的廢棄處理應根據所有國家的法律和規章進行。

Warnung

Die Entsorgung dieses Produkts sollte gemäß allen Bestimmungen und Gesetzen des Landes erfolgen.

¡Advertencia!

Al deshacerse por completo de este producto debe seguir todas las leyes y reglamentos nacionales.

Attention

La mise au rebut ou le recyclage de ce produit sont généralement soumis à des lois et/ou directives de respect de l'environnement. Renseignez-vous auprès de l'organisme compétent.

סילוק המוצר

אזהרה!

סילוק סופי של מוצר זה חייב להיות בהתאם להנחיות וחוקי המדינה.

عند التخلص النهائي من هذا المنتج ينبغي التعامل معه وفقا لجميع القوانين واللوائح الوطنية

경고!

이 제품은 해당 국가의 관련 법규 및 규정에 따라 폐기되어야 합니다.

Waarschuwing

De uiteindelijke verwijdering van dit product dient te geschieden in overeenstemming met alle nationale wetten en reglementen.

Appendix C

UEFI BIOS Recovery

Warning: Do not upgrade the BIOS unless your system has a BIOS-related issue. Flashing the wrong BIOS can cause irreparable damage to the system. In no event shall Supermicro be liable for direct, indirect, special, incidental, or consequential damages arising from a BIOS update. If you need to update the BIOS, do not shut down or reset the system while the BIOS is updating. Doing so may cause a boot failure.

C.1 Overview

The Unified Extensible Firmware Interface (UEFI) provides a software-based interface between the operating system and the platform firmware in the pre-boot environment. The UEFI specification supports an architecture-independent mechanism for add-on card initialization to allow the UEFI OS loader, which is stored in the add-on card, to boot the system. The UEFI offers clean, hands-off control to a computer system at bootup.

C.2 Recovering the UEFI BIOS Image

A UEFI BIOS flash chip consists of a recovery BIOS block and a main BIOS block (a main BIOS image). The boot block contains critical BIOS codes, including memory detection and recovery codes for the user to flash a new BIOS image if the original main BIOS image is corrupted. When the system power is on, the boot block codes execute first. Once it is completed, the main BIOS code will continue with system initialization and bootup.

C.3 Recovering the BIOS Block with a USB Device

If the BIOS file is corrupted and the system is not able to boot up, this feature will allow you to recover the BIOS image using a USB-attached device. A USB flash drive or a USB CD/DVD ROM drive may be used for this purpose. Please note that a USB hard disk drive is NOT supported. Follow the procedures on the next page to recover the BIOS.

Using a different system, copy the standard BIOS binary image file into the root directory of a USB flash drive with FAT16 or FAT32 format and rename the file to SUPER.ROM.

Note: If you cannot locate the "SUPER.ROM" file in your driver disk, visit our website at www.supermicro.com to download the correct BIOS image into a USB flash device and rename it "SUPER.ROM".

1. While the system is turned off, insert the USB device that contains the new BIOS binary image (SUPER.ROM).
2. Power on the system.



3. After the system is turned on, the system will enter the BIOS Recovery menu. Select "Proceed with flash update" to start the BIOS recovery process. **DO NOT INTERRUPT THIS PROCESS UNTIL IT FINISHED!**

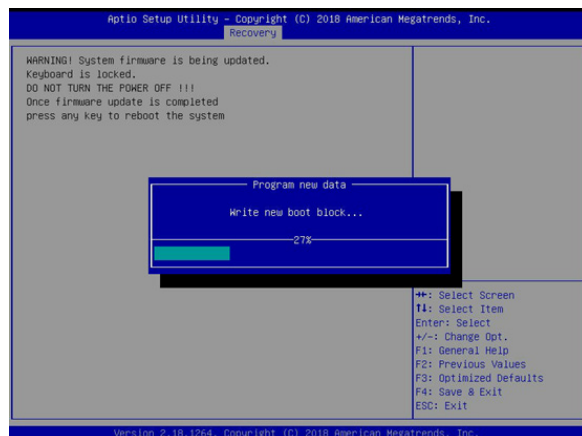
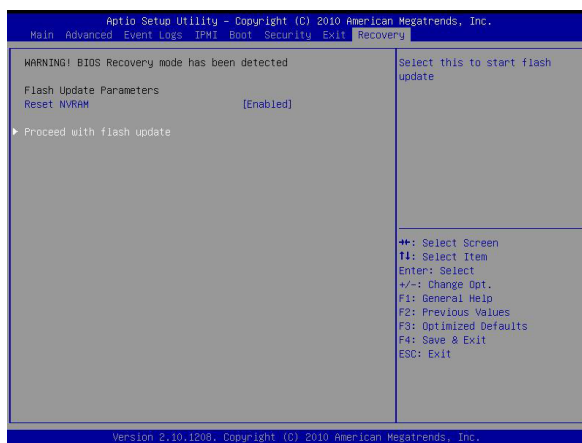

4. After the Boot Sector Recovery Process is complete, press any key to reboot the system.

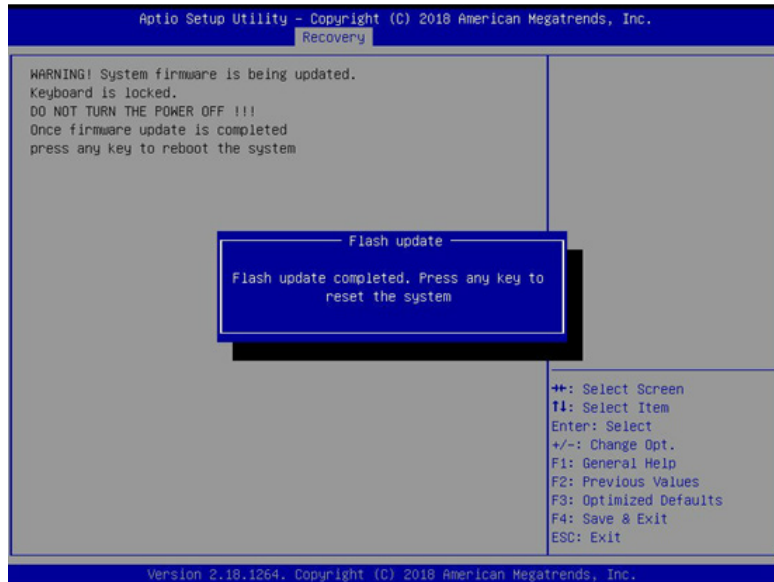
**Notes:**

- The BIOS recovery (SUPER.ROM) will not work if BIOS has a multi-block crash.
- To recover the BIOS using a USB flash drive, insert the drive to one of these USB ports: USB12, USB8, USB6 or USB7.



- If you have purchased an OOB license, you can flash the BIOS again through BMC, WebGUI, or SUM. Please refer to these SUPERMICRO software-related videos:
- Activate OOB license: https://www.youtube.com/watch?v=V4spX_DOV7I
- SUPERMICO BIOS Update: <https://www.youtube.com/watch?v=S8z6iOEHGwY>
- If the BIOS flash recovery fails, contact our RMA Department to have the BIOS chip reprogrammed. This will require shipping the board to Supermicro for repair.
- Submit your RMA request at <https://www.supermicro.com/support/rma>
- Please make sure to follow all instructions when returning the motherboard.

Appendix D

RAID Arrays

Notes:

- RAID configuration support is available for both SATA and NVMe drives, however, mixed use of SATA and NVMe drives is not allowed. You must use hard drives of the same type.
- The onboard M.2 slots do not support M.2 drives with a SATA interface. No RAID configuration support is available for this type of drives.

D.1 Enabling RAID Mode

To enable RAID for AMD processors, configure the settings in BIOS. The following steps are illustrated with the example using SATA drives for RAID configuration.

Enabling RAID Mode

1. Entering the BIOS setup utility and press **<Delete>** while the system is booting-up.

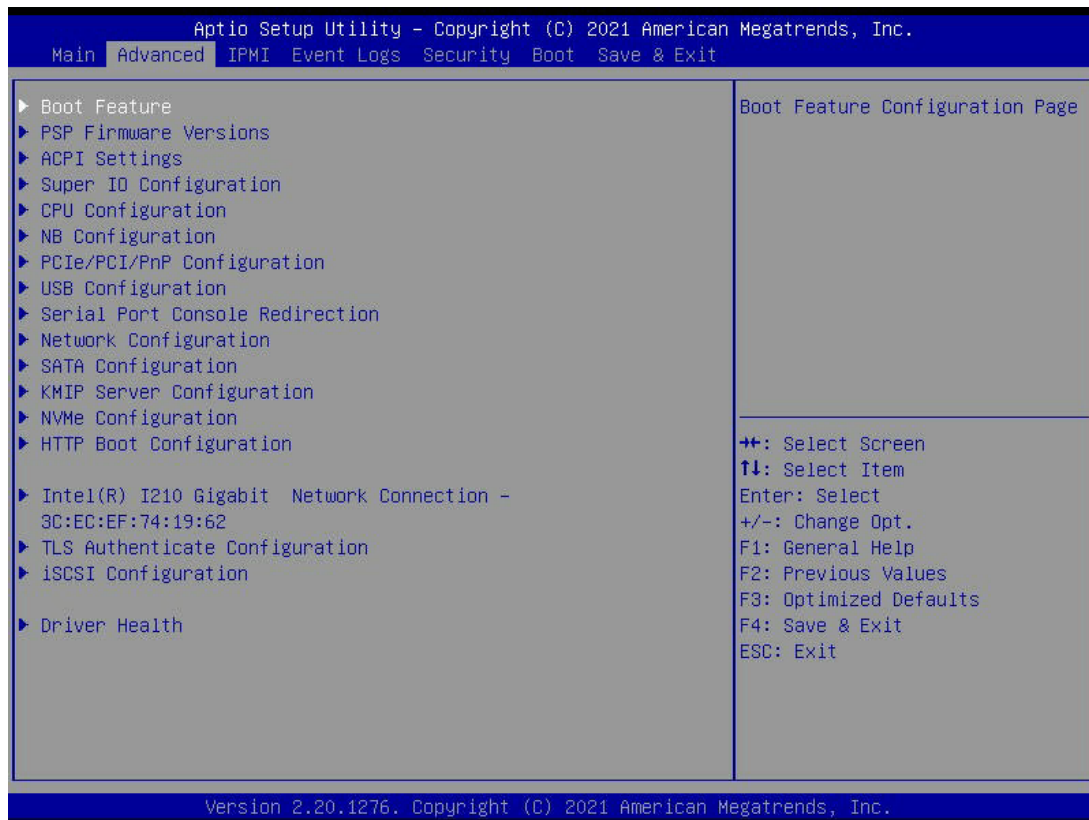

2. Use the arrow key to switch to the Advanced tab.
3. Use the arrow key to locate SATA Configuration and press **<Enter>**.

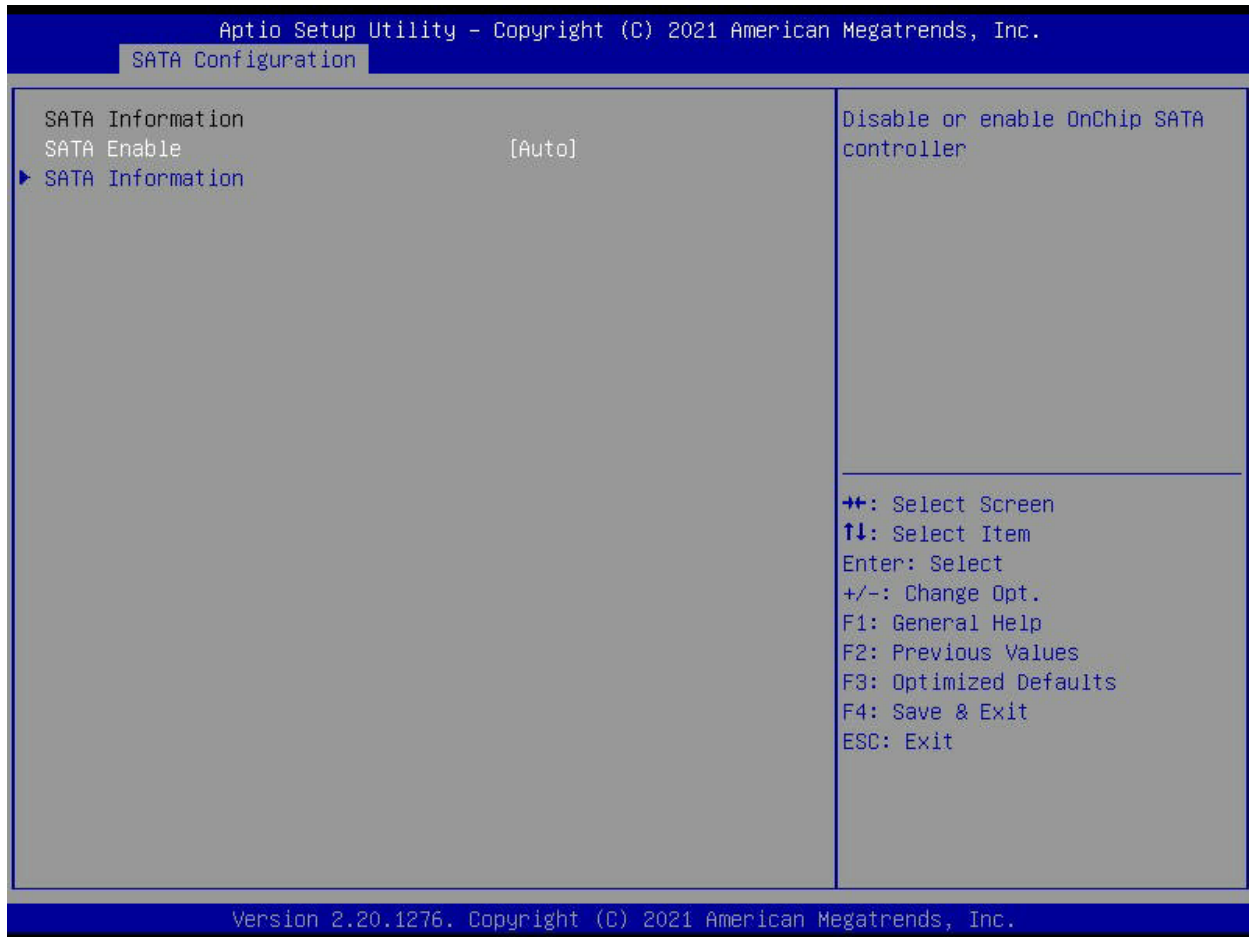

4. Select **SATA Enable**, select **Enabled**, and press **<Enter>** to enable OnChip SATA controller.
5. Follow steps 1 and 2 to enter the Advanced submenu. The item RAIDXpert2 Configuration Utility should appear.

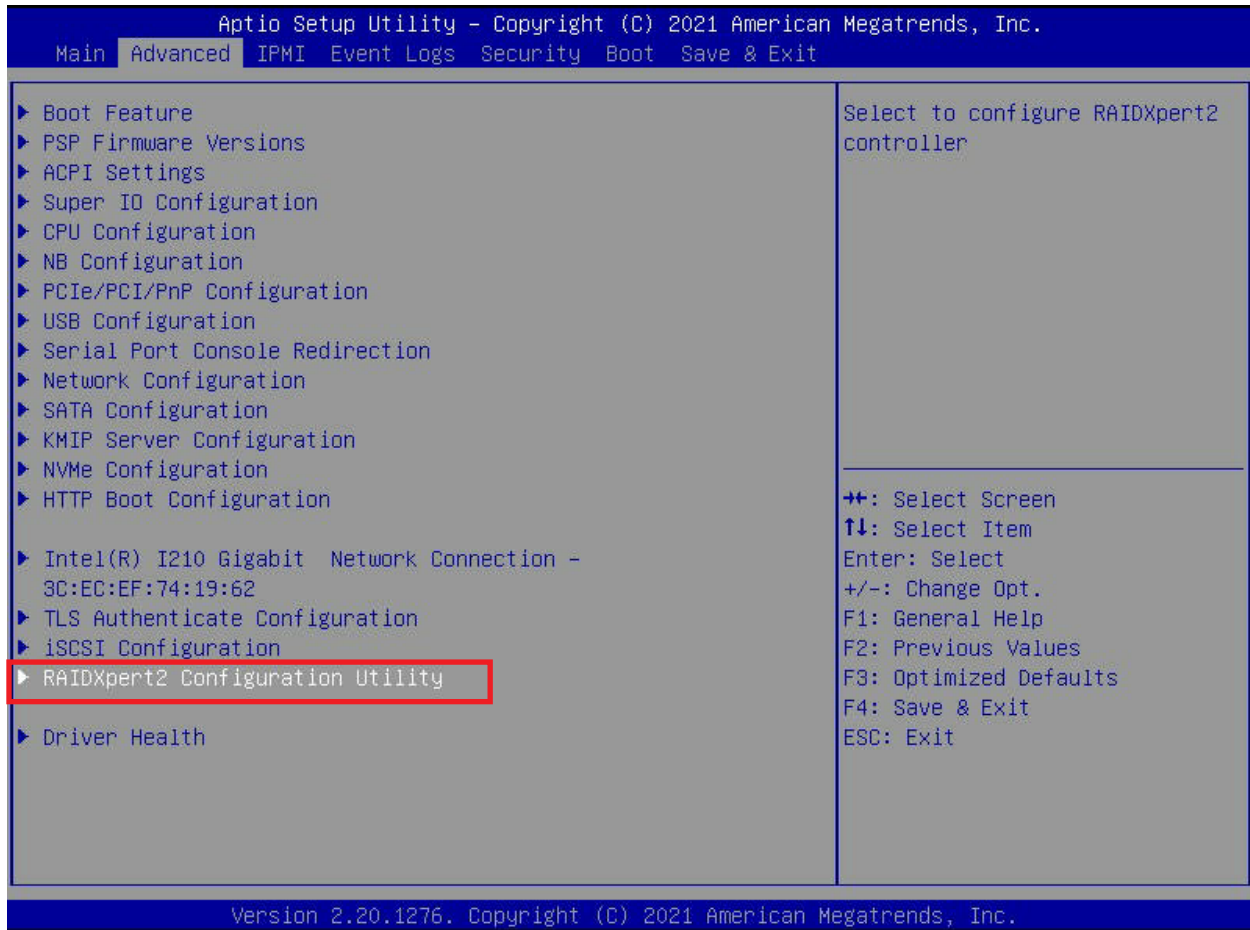

Note: To use NVMe drives for RAID configuration, use the arrow key while on the Advanced tab to locate NVMe Configuration and press **<Enter>**. Select **NVMe RAID mode**, select **Enabled**, press **<Enter>** to enable NVMe RAID mode, and then return to the Advanced submenu.

D.2 Creating RAID Arrays

1. Select the RAIDXpert2 Configuration Utility item on the Advanced submenu and press the <Enter> key.
2. Select **Array Management** and press the <Enter> key.

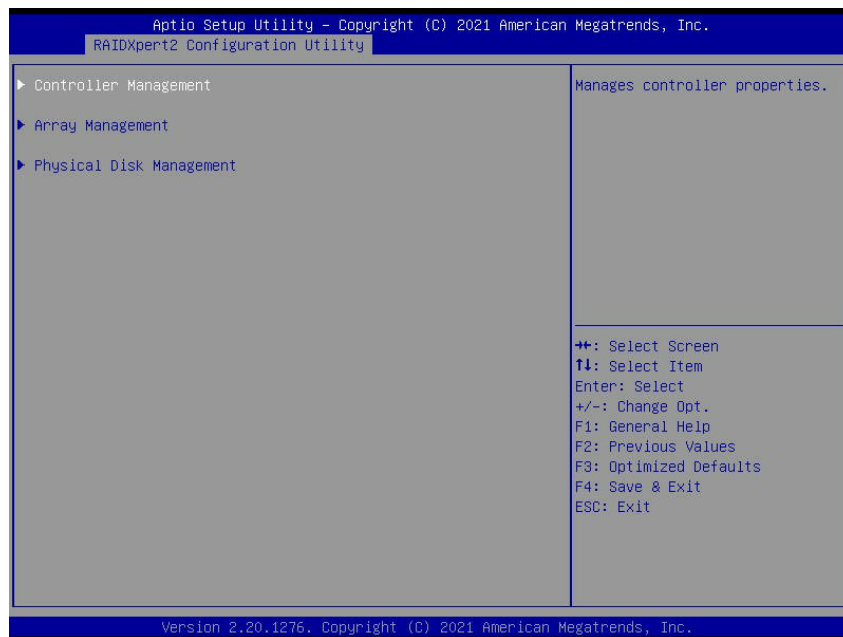

3. Select **Create Array** and press the <Enter> key.

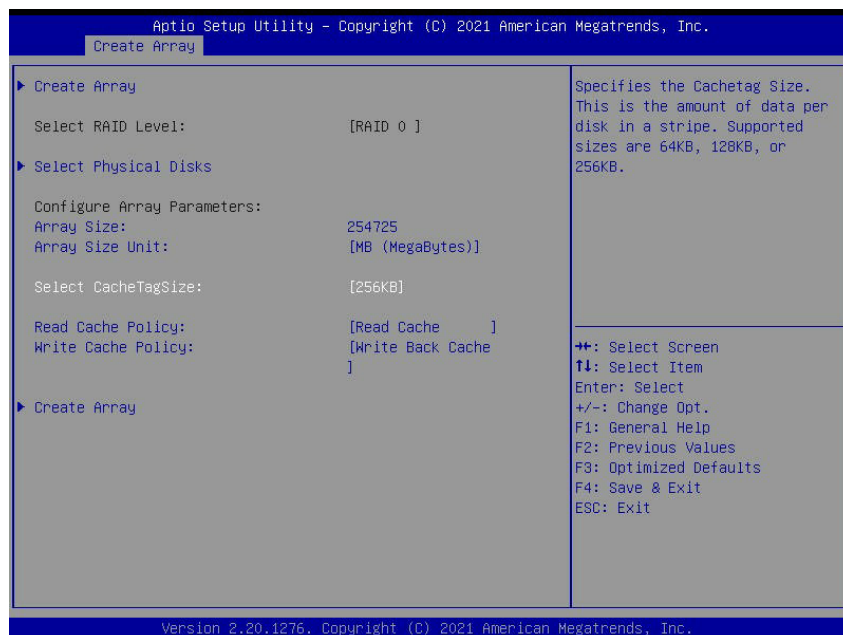

4. Use the arrow key to select **Select RAID Level** and press the **<Enter>** key. Select the option to set your RAID level.
 - **Volume:** Single disk or concatenation of disks (JBOD).
 - **RAIDABLE:** RAID aware single disk for future redundancy.
 - **RAID 0:** Striping two or more disks.
 - **RAID 1:** Mirroring two disks.
 - **RAID 5:** Striping at least three disks.
 - **RAID 10:** Combining both levels 1 (disk mirroring) and 0 (disk striping), also known as RAID 1 + RAID 0.
5. Use the arrow key to select **Select Physical Disks**.

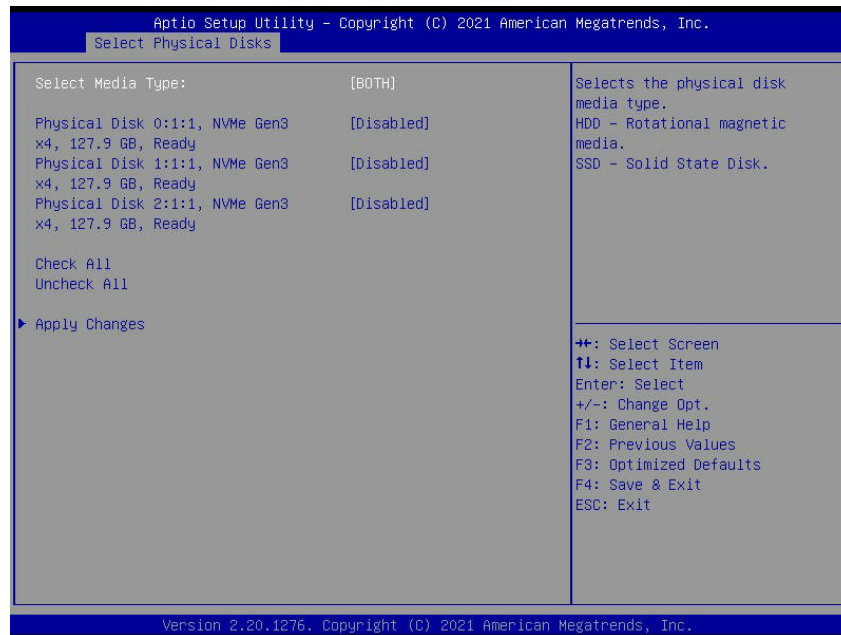

6. Enter **Select Media Type** to select the types of disks. The options include BOTH, HDD and SSD.
7. Select the desired option and press the **<Enter>** key to enable them or select Check All to enable all available disks.
8. Select **Apply Changes** and press the **<Enter>** key.
9. Use the arrow key to select **Create Array** and press the **<Enter>** key to create the array.

D.3 Deleting RAID Arrays

1. Enter the RAIDXpert2 Configuration Utility item on the Advanced Submenu.
2. Select **Array Management**, and **Delete Array**, and press the **<Enter>** key.

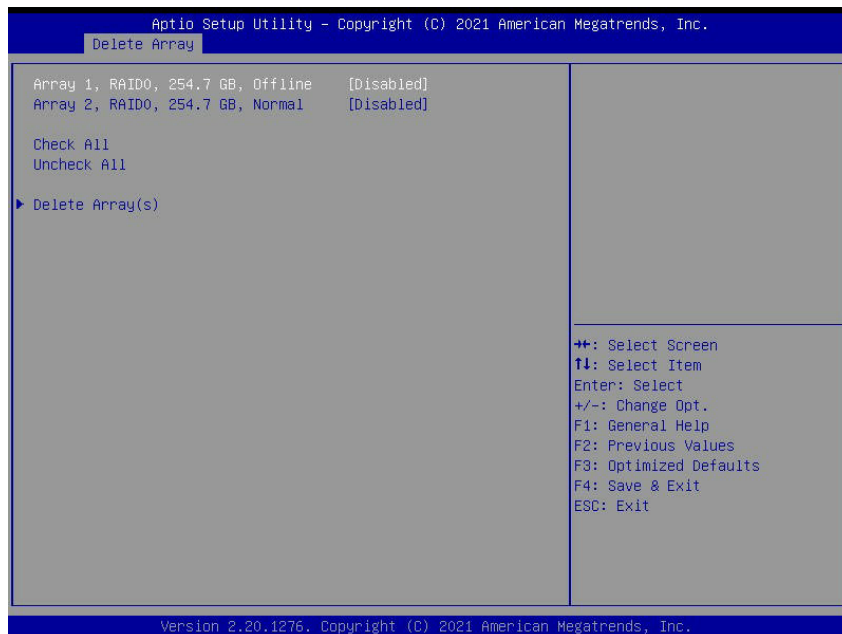

3. Select **Confirm**, press the **<Enter>** key to select **Enabled**, and then use the arrow key to select **YES** to confirm your deletion.

