

SUPER●

SUPER●[®]X6DHP-3G2

USER'S MANUAL

Revision 1.0

The information in this User's Manual has been carefully reviewed and is believed to be accurate. The vendor assumes no responsibility for any inaccuracies that may be contained in this document, makes no commitment to update or to keep current the information in this manual, or to notify any person or organization of the updates.

Please Note: For the most up-to-date version of this manual, please see our web site at www.supermicro.com.

SUPERMICRO COMPUTER reserves the right to make changes to the product described in this manual at any time and without notice. This product, including software, if any, and documentation may not, in whole or in part, be copied, photocopied, reproduced, translated or reduced to any medium or machine without prior written consent.

IN NO EVENT WILL SUPERMICRO COMPUTER BE LIABLE FOR DIRECT, INDIRECT, SPECIAL, INCIDENTAL, OR CONSEQUENTIAL DAMAGES ARISING FROM THE USE OR INABILITY TO USE THIS PRODUCT OR DOCUMENTATION, EVEN IF ADVISED OF THE POSSIBILITY OF SUCH DAMAGES. IN PARTICULAR, THE VENDOR SHALL NOT HAVE LIABILITY FOR ANY HARDWARE, SOFTWARE, OR DATA STORED OR USED WITH THE PRODUCT, INCLUDING THE COSTS OF REPAIRING, REPLACING, INTEGRATING, INSTALLING OR RECOVERING SUCH HARDWARE, SOFTWARE, OR DATA.

Any disputes arising between manufacturer and customer shall be governed by the laws of Santa Clara County in the State of California, USA. The State of California, County of Santa Clara shall be the exclusive venue for the resolution of any such disputes. Supermicro's total liability for all claims will not exceed the price paid for the hardware product.

Unless you request and receive written permission from SUPER MICRO COMPUTER, you may not copy any part of this document.

Information in this document is subject to change without notice. Other products and companies referred to herein are trademarks or registered trademarks of their respective companies or mark holders.

Copyright © 2005 by SUPER MICRO COMPUTER INC.
All rights reserved.

Printed in the United States of America

Preface

About This Manual

This manual is written for system integrators, PC technicians and knowledgeable PC users. It provides information for the installation and use of the **SUPER** X6DHP-3G2 motherboard. The X6DHP-3G2 supports single or dual Intel® Xeon 64-bit processors at a 800 MHz front side bus. Based on Intel's Xeon EM64T Processor (800 MHz) and the E7520 chipset, the X6DHP-3G2 supports Intel's Hyper-Threading Technology (HT), the EM64T Technology, the Enhanced Intel SpeedStep Technology (EIST) and is ideal for high performance server environments with up to two processors on one system bus. The **SUPER** X6DHP-3G2 motherboard is intended to be professionally installed.

Manual Organization:

Chapter 1 describes the features, specifications and performance of the mainboard and provides detailed information about the chipset.

Chapter 2 provides hardware installation instructions. Read this chapter when installing the processor, memory modules and other hardware components into the system. If you encounter any problems, see **Chapter 3**, which describes troubleshooting procedures for the video, the memory and the system setup stored in CMOS.

Chapter 4 includes an introduction to BIOS and provides detailed information on running the CMOS Setup utility.

Appendix A provides BIOS POST Messages.

Appendix B lists BIOS POST Codes.

Appendix C lists Software Installation Instructions.

Conventions Used in the Manual:

Special attention should be given to the following symbols for proper installation and to prevent damage done to the components or injury to yourself:



Danger/Caution: Instructions to be strictly followed to prevent catastrophic system failure or to avoid bodily injury.



Warning: Important information given to ensure proper system installation or to prevent damage to the components.

(***Note**): **Note:** Additional Information given to differentiate various models or to ensure correct system setup.

Table of Contents

Preface

About This Manual	iii
Manual Organization	iii
Conventions Used in the Manual	iii

Chapter 1: Introduction

1-1 Overview	1-1
Checklist	1-1
Contacting Supermicro	1-2
SUPER [®] X6DHP-3G2 Image	1-3
SUPER [®] X6DHP-3G2 Layout	1-4
SUPER [®] X6DHP-3G2 Quick Reference	1-5
Motherboard Features.....	1-6
Intel E7520 (Lindenhurst) Chipset: System Block Diagram	1-8
1-2 Chipset Overview	1-9
1-3 Special Features	1-10
1-4 PC Health Monitoring	1-10
1-5 ACPI Features	1-11
1-6 Power Supply	1-12
1-7 Super I/O	1-12

Chapter 2: Installation

2-1 Static-Sensitive Devices	2-1
Precautions.....	2-1
Unpacking	2-1
2-2 Xeon EM64T Processor and Heatsink Installation	2-2
2-3 Installing DIMMs	2-6
2-4 I/O Ports/Control Panel Connectors	2-7
2-5 Connecting Cables	2-9
ATX Power Connector	2-9
Secondary Power Connector	2-9
NMI Button	2-10
Power LED	2-10
HDD LED	2-11
NIC1/NIC2 LED	2-11
Overheat/Fan Fail LED	2-12
PWR Fail LED	2-12
Front_UID & UID_LED.....	2-13

	Power Button	2-13
	Chassis Intrusion	2-14
	Serial Ports	2-14
	Universal Serial Bus Headers (USB2/3)	2-15
	GLAN (Ethernet Ports)	2-16
	ATX PS/2 Keyboard and Mouse Ports	2-16
	Fan Headers	2-17
	Power LED/Speaker Header	2-17
	Wake-On-Ring	2-18
	Alarm Reset	2-18
	SMB	2-19
	PWR SMB Connector	2-19
2-6	Jumper Settings	2-20
	Explanation of Jumpers	2-20
	GLAN Enable/Disable	2-20
	CMOS Clear	2-21
	SAS Enable/Disable	2-21
	VGA Enable/Disable	2-22
	DOC IDE Slot Bus Select	2-22
	Watch Dog Enable/Disable	2-23
2-7	Onboard Indicators	2-23
	GLAN LEDs	2-23
	SCSI LED Indicators	2-23
	Unit Identification	2-24
2-8	Floppy/Hard Disk Drive, 1U IPMI, and SCSI Connections	2-25
	Floppy Connector	2-25
	IDE Connectors	2-26
	1U IPMI Connection	2-26
 Chapter 3: Troubleshooting		
3-1	Troubleshooting Procedures	3-1
	Before Power On	3-1
	No Power	3-1
	No Video	3-1
	Memory Errors	3-2
	Losing the System's Setup Configuration	3-2
3-2	Technical Support Procedures	3-2
3-3	Frequently Asked Questions	3-3
3-4	Returning Merchandise for Service	3-4

Chapter 4: BIOS

4-1	Introduction	4-1
4-2	Running Setup	4-2
4-3	Main BIOS Setup	4-2
4-4	Advanced Setup	4-6
4-5	Security Setup	4-16
4-6	Boot Setup	4-18
4-7	Exit	4-19

Appendices:

Appendix A: BIOS POST Codes	A-1
Appendix B: Installing Software Drivers and the Operating System	B-1

Chapter 1

Introduction

1-1 Overview

Checklist

Congratulations on purchasing your computer motherboard from an acknowledged leader in the industry. Supermicro boards are designed with the utmost attention to detail to provide you with the highest standards in quality and performance. Check that the following items have all been included with your motherboard. If anything listed here is damaged or missing, contact your retailer.

One (1) Supermicro Mainboard

One (1) ribbon cable for IDE devices (CBL-036)

One (1) floppy ribbon cable (CBL-022)

One (1) User's/BIOS Manual

Contacting Supermicro

Headquarters

Address: SuperMicro Computer, Inc.
980 Rock Ave.
San Jose, CA 95131 U.S.A.

Tel: +1 (408) 503-8000

Fax: +1 (408) 503-8008

Email: marketing@supermicro.com (General Information)
support@supermicro.com (Technical Support)

Web Site: www.supermicro.com

Europe

Address: SuperMicro Computer B.V.
Het Sterrenbeeld 28, 5215 ML
's-Hertogenbosch, The Netherlands

Tel: +31 (0) 73-6400390

Fax: +31 (0) 73-6416525

Email: sales@supermicro.nl (General Information)
support@supermicro.nl (Technical Support)
rma@supermicro.nl (Customer Support)

Asia-Pacific

Address: SuperMicro, Taiwan
4F, No. 232-1 Liancheng Road
Chung-Ho 235, Taipei Hsien, Taiwan, R.O.C.

Tel: +886-(2) 8226-3990

Fax: +886-(2) 8226-3991

Web Site: www.supermicro.com.tw

Technical Support:

Email: support@supermicro.com.tw

Tel: 886-2-8228-1366, ext.132 or 139

Figure 1-1. SUPER[®] X6DHP-3G2 Image



Figure 1-2. SUPER® X6DHP-3G2 Motherboard Layout
(not drawn to scale)

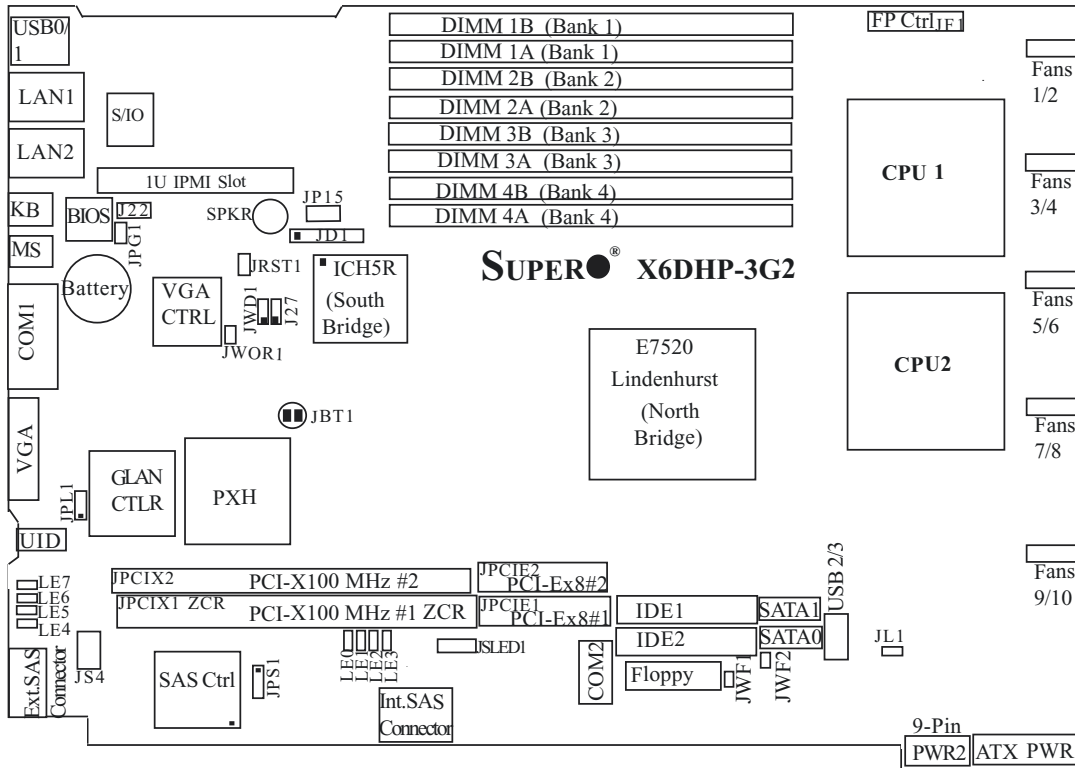

Notes:

1. Jumpers not indicated are for testing only.
2. See Chapter 2 for detailed information on jumpers, I/O ports and JF1 front panel connections.
3. "■" indicates the location of Pin 1.
4. For RAID to function properly, please install the ZCR Card in the right hand-side slot.
5. When the Onboard Standby PWR LED Indicator is on, it indicates that the Power and the system is on. Do not remove or install any components without turning off the system and disconnecting the AC power.
6. The drawings and pictures shown in this manual were based on the latest PCB Revision available at the time of publishing of the manual. The motherboard you've received may or may not look exactly the same as the graphics shown in the manual.

Quick Reference (*See Chapter 2 for details.)

Jumper	Description	Default Setting
J27	BIOS Debug	Pins 1-2 (Enabled)
JP15	Reboot Option	Closed (Enabled)
JBT1	CMOS Clear	See Chapter 2
JPG1	VGA Enable	Pins 1-2 (Enabled)
JPL1	GLAN Enable	Pins 1-2 (Enabled)
JPS1	SAS Enable	Pins 1-2 (Enabled)
JWD1	Watch Dog Enable	Pins 1-2 (Reset)

Connector	Description
ATX PWR1 (JWR1)	Primary 20-Pin ATX PWR Connector
PWR2 (JPWR1)	9-pin Secondary PWR Connector
COM1/COM2 (JCOM1/2)	COM1/COM2 Serial Port Connectors
DIMM#1A-DIMM#4B	DDR DIMM Memory (RAM) Slots
Fans 1-10	CPU/Chassis/Overheat Fan Headers
Floppy (JFDD1)	Floppy Disk Drive Connector
IDE1/2 (JIDE1/2)	IDE#1/IDE#2 Hard Disk Drive Connectors
I-SATA 0/1	ICH5R Serial ATA0/1 Ports
J1	1U IPMI slot
J22	System Management Bus Connector
JD1	PWR LED(pins1-3)/SpeakerHeader(pins 4-7)
JF1	Front Control Panel Connector
JFW1/JFW2 (*OEM Only)	DOC Power Connectors (JFW1: IDE1, JFW2: IDE2)
JL1	Chassis Intrusion Header
JLAN 1/2	G-bit Ethernet (GLAN) Ports 1/2
JRST 1	Alarm Reset
JS4	Power System Management Bus Connector
JSLED1	SAS Activity LED Connector
JWOR1	Wake-on-Ring (WOR) Header
KB/Mouse (JKB1/JMS1)	PS2 Keyboard Connector (JKB1)/Mouse (JMS1)
PCI-X#1/PCI-X#2	PCI-X 100 MHz ZCR Slot1/PCI-X 100 MHz (Slim)Slot2
PCI-E#1/PCI-E#2	PCI-Express x8 Slot1/Slot2 (JPCIE1/2)
Ext. SAS Conn.(JSM1)	External SAS Connector
Int. SAS Conn. (JSM2)	Internal SAS (x4) Connector
Speaker (SP1)	Internal Speaker
UID	Unit Identification Button
USB 0/1 (JUSB1)	Back Panel USB0/USB1 Headers
USB 2/3 (JUSB2)	Front Panel Universal Serial Bus USB2/USB3 Ports
VGA (JVGA1)	Video Connector
LED	Description
LE 0-3	Internal SAS Activity LED Indicators
LE 4-7	External SAS Activity LED Indicators

Motherboard Features

CPU

- Single or dual Intel[®] Xeon[™] 64-bit processors at 800 MHz front side (system) bus speed with support of Hyper-Threading (HT), EM64T and Enhanced Intel SpeedStep (EIST)

Using the EM64T Feature

- Install a 64-bit OS (Windows XP Professional x64 Ed, Server 2003x64 Ed.)
- Install a 64-bit OS (Windows XP Professional x64 Ed, Server 2003x64 Ed.)
- Install the 64-bit drivers for all MB components, devices and add-on cards

Using the Hyper-Threading (HT) Technology

- Install an OS that supports HT, including Windows XP/2003 Server and Linux 2.4x. (Under Linux, use the HT compiler to compile the code. For other operating systems, be sure to disable the HT feature in the BIOS.)
- Enable the HT feature in the BIOS (under "Advanced" Setting) before installing a supported OS. (*Note: visit www.Intel.com for CPU support and driver updates.)

Memory

- Eight 240-pin DIMM sockets supporting up to 16 GB Registered ECC, dual channel, DDR II 400 (PC3200) SDRAM

Chipset

- Intel E7520
- Intel ICH5R + PXH

Expansion Slots

- One PCI-X 100 MHz ZCR slot (Slot#1), One PCI-X 100MHz slot (Slot#2)
- Two PCI-Express x8 slots

BIOS

- 8 Mb Phoenix[®] Flash ROM
- APM 1.2, DMI 2.1, PCI 2.2, ACPI 1.0, Plug and Play (PnP), SMBIOS 2.3

PC Health Monitoring

- Onboard voltage monitors for CPU cores, chipset voltage, 3.3V, +5V, +12V, -12V and +5V standby
- Fan status monitor with firmware control
- CPU/chassis temperature monitors
- Environmental temperature monitor and control
- CPU fan auto-off in sleep mode
- CPU slow-down on temperature overheat

- CPU thermal trip support for processor protection, +5V standby alert LED
- Power-up mode control for recovery from AC power loss
- Auto-switching voltage regulator for CPU core
- System overheat/Fan Fail LED Indicator and control
- Chassis intrusion detection
- System resource alert via Supero Doctor III

ACPI Features

- Microsoft OnNow
- ACPI/ACPM Power Management
- Wake-On Ring (WOR) Header
- Internal/External Modem Ring On
- Wake-On LAN (WOL) Header
- Slow blinking LED for suspend state indicator
- Main switch override mechanism

Onboard I/O

- SAS 9410 Controller supports 4 External and 4 Internal SAS ports
- One 1U IPMI slot
- Intel 82546GB Gigabit Ethernet controller support two GLAN ports
- 2 EIDE Ultra DMA/100 bus master interfaces
- 1 floppy port interface
- PS/2 mouse and PS/2 keyboard ports
- Up to 4 USB 2.0 (Universal Serial Bus) (2 ports, 2 Headers)
- Super I/O (Winbond W83627 HF) w/Hardware Monitoring (W83792D)
- Intel ICH5R supports 2 SATA ports (2 drives) (RAID 0, 1, JBOD)
- ATI 8 MB Rage XL Graphic Card
- 1 COM Port and 1 Header

Other

- Internal/external modem ring-on
- Console redirection
- SMBus for SMC Power Supply
- Fan Speed Control by Thermal Management (via BIOS)

CD/Diskette Utilities

- BIOS flash upgrade utility and device drivers

Dimensions

- 11.2" x 16.2" (244.5 x 411.5 mm)

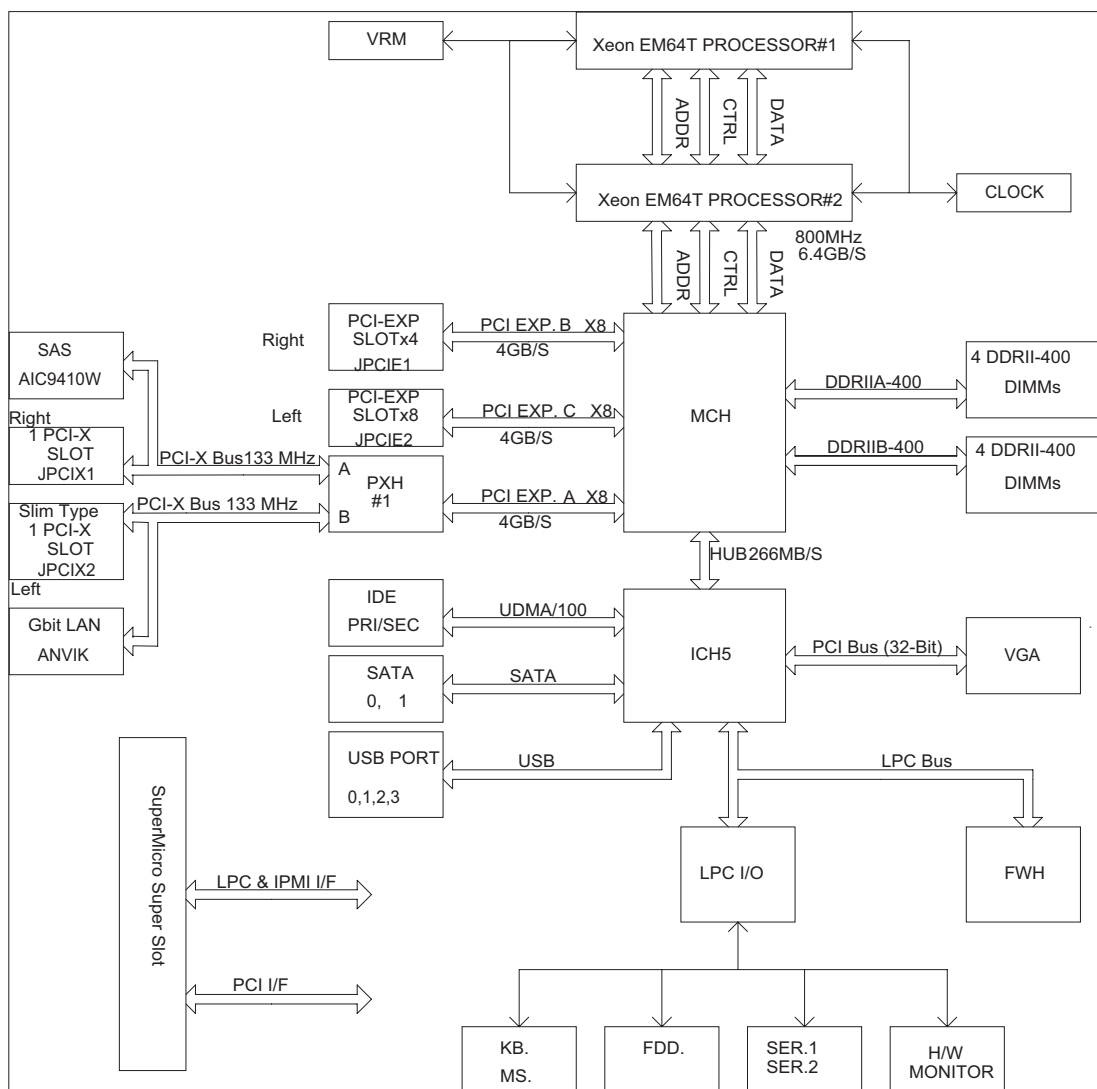

Figure 1-9. Block Diagram of the E7520 (Lindenhurst) Chipset

Note: This is a general block diagram. Please see the previous Motherboard Features pages for details on the features of the motherboard.

1-2 Chipset Overview

Built upon the functionality and the capability of the 7520 Lindenhurst chipset, the X6DHP-3G2 motherboard provides the performance and feature set required for dual processor-based servers, with configuration options optimized for communications, presentation, storage, computation or database applications. The Intel E7520 (Lindenhurst) chipset consists of the following components: the Lindenhurst Memory Controller Hub (MCH), the ICH5R I/O Controller Hub, and the Intel PCI-X Hub (PXH).

The E7520 MCH supports single or dual Xeon EMT64 (Nocona) processors with Front Side Bus speeds of 800 MHz. Its memory controller provides direct connection to two channels of registered DDR-II 400 with a marched system bus address and data bandwidths. The E7520 also supports the new PCI high speed serial I/O interface for superior I/O bandwidth. The MCH interfaces with the ICH5R I/O Controller Hub (ICH5R) via a dedicated Hub Interface. The PXH provides connection between a PCI interface and two independent PCI bus interfaces that can be configured for standard PCI -X 1.0 protocol.

ICH5R System Features

In addition to providing the I/O subsystem with access to the rest of the system, the ICH5R I/O Controller Hub integrates many I/O functions.

The ICH5R I/O Controller Hub integrates: 2-channel Ultra ATA/100 Bus Master IDE Controller, two Serial ATA (SATA) Host w/RAID0, RAID1 support, SMBus 2.0 Controller, LPC/Flash BIOS Interface, PCI 2.2 Interface and System Management Controller.

1-3 Special Features

Recovery from AC Power Loss

BIOS provides a setting for you to determine how the system will respond when AC power is lost and then restored to the system. You can choose for the system to remain powered off (in which case you must hit the power switch to turn it back on) or for it to automatically return to a power-on state. See the Power Lost Control setting in the Advanced BIOS Setup section (Peripheral Device Configuration) to change this setting. The default setting is Stay Off.

1-4 PC Health Monitoring

This section describes the PC health monitoring features of the SUPER X6DHP-3G2. All have an onboard System Hardware Monitor chip that supports PC health monitoring.

Onboard Voltage Monitors for the CPU Cores, +3.3V, +5V, +12V, and -12V

An onboard voltage monitor will scan these voltages continuously. Once a voltage becomes unstable, a warning is given or an error message is sent to the screen. Users can adjust the voltage thresholds to define the sensitivity of the voltage monitor.

Fan Status Monitor via BIOS and SDIII

The PC health monitor can check the RPM status of the cooling fans. The onboard CPU and chassis fans are controlled by Thermal Management via BIOS and Supero Doctor III.

Environmental Temperature Control

The thermal control sensor monitors the CPU temperature in real time and will turn on the thermal control fan whenever the CPU temperature exceeds a user-defined threshold. The overheat circuitry runs independently from the CPU. It can continue to monitor for overheat conditions even when the CPU is in sleep mode. Once it detects that the CPU temperature is too high, it will automatically turn on the thermal control fan to prevent any overheat damage to the CPU. The onboard chassis thermal circuitry can monitor the overall system temperature and alert users when the chassis temperature is too high.

CPU Fan Auto-Off in Sleep Mode

The CPU fan activates when the power is turned on. It continues to operate when the system enters Standby mode. When in sleep mode, the CPU will not run at full power, thereby generating less heat.

CPU Overheat LED and Fan Fail Control

This feature is available when the user enables the CPU overheat/Fan Fail warning function in the BIOS. This allows the user to define an overheat temperature. When this temperature is exceeded, both the overheat fan and the warning LED are triggered.

System Resource Alert

This feature is available when used with Supero Doctor III in the Windows OS environment or used with Supero Doctor II in Linux. SDIII is used to notify the user of certain system events. For example, if the system is running low on virtual memory and there is insufficient hard drive space for saving the data, you can be alerted of the potential problem.

1-5 ACPI Features

ACPI stands for Advanced Configuration and Power Interface. The ACPI specification defines a flexible and abstract hardware interface that provides a standard way to integrate power management features throughout a PC system, including its hardware, operating system and application software. This enables the system to automatically turn on and off peripherals such as CD-ROMs, network cards, hard disk drives and printers. This also includes consumer devices connected to the PC such as VCRs, TVs, telephones and stereos.

In addition to enabling operating system-directed power management, ACPI provides a generic system event mechanism for Plug and Play and an operating system-independent interface for configuration control. ACPI leverages the Plug and Play BIOS data structures while providing a processor architecture-independent implementation that is compatible with Windows 2000, Windows XP and Windows 2003.

Slow Blinking LED for Suspend-State Indicator

When the CPU goes into a suspend state, the chassis power LED will start blinking to indicate that the CPU is in suspend mode. When the user presses any key, the CPU will wake-up and the LED will automatically stop blinking and remain on.

Main Switch Override Mechanism

When an ATX power supply is used, the power button can function as a system suspend button to make the system enter a SoftOff state. The monitor will be suspended and the hard drive will spin down. Depressing the power button again will cause the whole system to wake-up. During the SoftOff state, the ATX power supply provides power to keep the required circuitry in the system alive. In case the system malfunctions and you want to turn off the power, just depress and hold the power button for 4 seconds. This option can be set in the Power section of the BIOS Setup routine.

External Modem Ring-On

Wake-up events can be triggered by a device such as the external modem ringing when the system is in the SoftOff state. Note that external modem ring-on can only be used with an ATX 2.01 (or above) compliant power supply.

1-6 Power Supply

As with all computer products, a stable power source is necessary for proper and reliable operation. It is even more important for processors that have high CPU clock rates. It is recommended that you use Supermicro's 816 chassis with the X6DHP-3G2 motherboard.

1-7 Super I/O

The disk drive adapter functions of the Super I/O chip include a floppy disk drive controller that is compatible with industry standard 82077/765, a data separator, write pre-compensation circuitry, decode logic, data rate selection, a clock generator, drive interface control logic and interrupt and DMA logic. The wide range of functions integrated onto the Super I/O greatly reduces the number of components required for interfacing with floppy disk drives. The Super I/O supports 360 K, 720K, 1.2 M, 1.44 M or 2.88 M disk drives and data transfer rates of 250 Kb/s, 500 Kb/s or 1 Mb/s. It also provides two high-speed, 16550 compatible serial communication ports (UARTs), one of which supports serial infrared communication. Each UART includes a 16-byte send/receive FIFO, a programmable baud rate generator, complete modem control capability and a processor interrupt system. Both UARTs provide legacy speed with baud rate of up to 115.2 Kbps as well as an advanced speed with baud rates of 250 K, 500 K, or 1 Mb/s, which support higher speed modems.

The Super I/O supports one PC-compatible printer port (SPP), Bi-directional Printer Port (BPP), Enhanced Parallel Port (EPP) or Extended Capabilities Port (ECP).

The Super I/O provides functions that comply with ACPI (Advanced Configuration and Power Interface), which includes support of legacy and ACPI power management through an SMI or SCI function pin.

The IRQs, DMAs and I/O space resources of the Super I/O can flexibly adjust to meet ISA PnP requirements, which support ACPI and APM (Advanced Power Management).

Chapter 2

Installation

2-1 Static-Sensitive Devices

Electric-Static-Discharge (ESD) can damage electronic components. To prevent damage to your system board, it is important to handle it very carefully. The following measures are generally sufficient to protect your equipment from ESD.

Precautions

- Use a grounded wrist strap designed to prevent static discharge.
- Touch a grounded metal object before removing the board from the antistatic bag.
- Handle the board by its edges only; do not touch its components, peripheral chips, memory modules or gold contacts.
- When handling chips or modules, avoid touching their pins.
- Put the motherboard and peripherals back into their antistatic bags when not in use.
- For grounding purposes, make sure your computer chassis provides excellent conductivity between the power supply, the case, the mounting fasteners and the motherboard.
- Use only the correct type of onboard CMOS battery. Do not install the onboard upside down battery to avoid possible explosion.

Unpacking

The motherboard is shipped in antistatic packaging to avoid static damage. When unpacking the board, make sure the person handling it is static protected.

2-2 Processor and Heatsink Installation



When handling the processor package, avoid placing direct pressure on the label area of the fan. Also, do not place the motherboard on a conductive surface, which can damage the BIOS battery and prevent the system from booting up.

IMPORTANT: Always connect the power cord last and always remove it before adding, removing or changing any hardware components. Make sure that you install the processor into the CPU socket **before** you install the CPU heat sink.

CPU Installation

1. Lift the lever on the CPU socket: lift the lever completely as shown on the picture on the right; otherwise, you will damage the CPU socket when power is applied. (Install CPU1 first.)

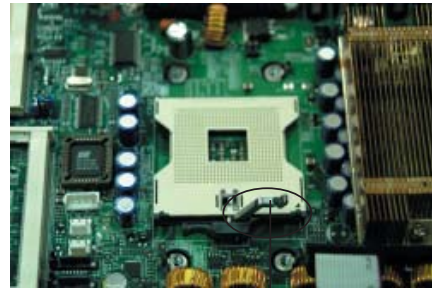

Socket lever

2. Insert the CPU in the socket, making sure that pin 1 of the CPU aligns with pin 1 of the socket (both corners are marked with a triangle). When using only one CPU, install it into CPU socket #1 (socket #2 is automatically disabled if only one CPU is used).



Pin 1

3. Press the lever down until you hear the *click* so you can be sure that the CPU is securely installed in the CPU socket.



Socket lever in the locking Position

CEK Heatsink Installation

(The CEK Heatsink is heavy; please handle with care.)

1. Do not apply any thermal compound to the heatsink or the CPU die-the required amount has already been applied.

2. Place the heatsink on top of the CPU so that the four mounting holes are aligned with those on the retention mechanism.

3. Screw in two diagonal screws (ie the #1 and the #2 screws) until just snug (-do not fully tighten the screws to avoid possible damage to the CPU.)

4. Finish the installation by fully tightening all four screws.

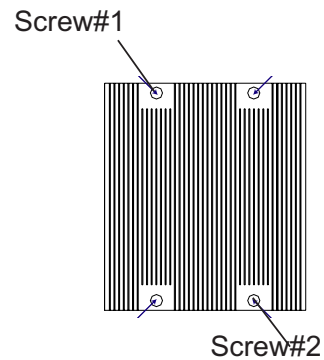
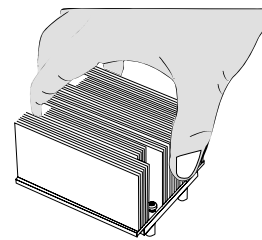
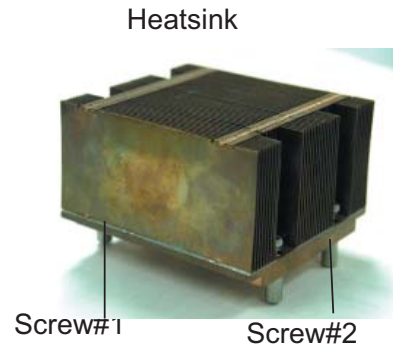

To Un-install the Heatsink



(Warning! We do not recommend that the CPU or the heatsink be removed. However, if you do need to un-install the heatsink, please follow the instructions below to un-install the heatsink to prevent damage done to the CPU or the CPU socket.)

1. Unscrew and remove the heatsink screws from the motherboard in the sequence as show in the picture on the right.

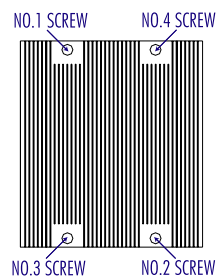

2. Hold the heatsink as show in the picture on the right and gently wriggle the heatsink to loosen it from the CPU. (Do not use excessive force when wriggling the heatsink!!)

3. Once the CPU is loosened, remove the heatsink from the CPU socket.

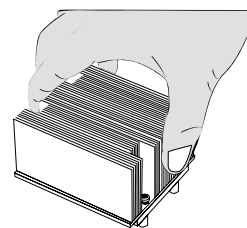

4. Clean the surface of the CPU and the heatsink to get rid of the old thermal grease. Reapply the proper amount of thermal grease on the surface before you re-install the CPU and the heatsink.

Figure 2-1. Processor Socket: Empty and with Processor Installed

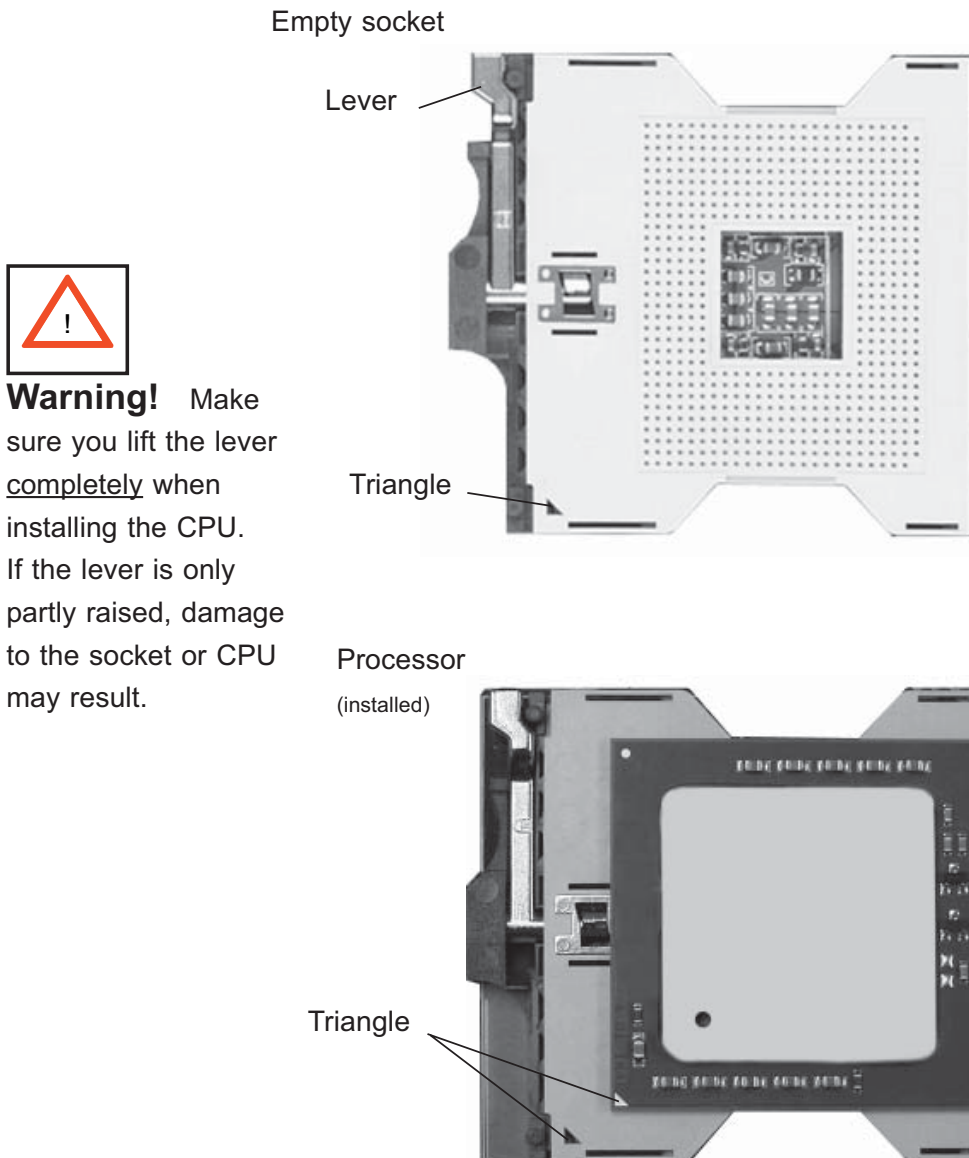

Warning! Make sure you lift the lever completely when installing the CPU. If the lever is only partly raised, damage to the socket or CPU may result.

Mounting the Motherboard in the Chassis

All motherboards have standard mounting holes to fit different types of chassis. Make sure that the locations of all mounting holes for both the motherboard and the chassis match. Although a chassis may have both plastic and metal mounting fasteners, metal ones are highly recommended because they ground the motherboard to the chassis. Make sure that the metal standoffs click in or are screwed in tightly. Then, use a screwdriver to secure the motherboard onto the motherboard tray. (*Note: Some of the components are located near to the mounting holes, please take caution when mounting the motherboard into the chassis to prevent damage done to these components.)

2-3 Installing DIMMs

CAUTION

Exercise extreme care when installing or removing DIMM modules to prevent any possible damage. Also note that the memory is interleaved to improve performance (see step 1).

DIMM Installation (See Figure 2-2 on Page 2-7)

1. Insert the desired number of DIMMs into the memory slots, starting with Bank 1. The memory scheme is interleaved so you must install two modules at a time, beginning with Bank 1, then Bank 2, and so on.
2. Insert each DIMM module vertically into its slot. Pay attention to the notch along the bottom of the module to prevent inserting the DIMM module incorrectly.
3. Gently press down on the DIMM module until it snaps into place in the slot. Repeat for all modules (see step 1 above).

(*Note: Check the Supermicro web site for recommended memory modules:
http://www.supermicro.com/TECHSUPPORT/FAQs/Memory_vendors.htm)

Memory Support

The X6DHP-3G2 supports up to 16 GB Registered ECC DDR-II 400 memory. The motherboard was designed to support 512MB, 1GB, 2GB (DDR-II 400) modules in each slot. Please refer to Supermicro's web site at www.supermicro.com for memory updates.

Figure 2-2. Installing and Removing DIMMs

To Install:

Insert module vertically and press down until it snaps into place. Pay attention to the alignment notch at the bottom.

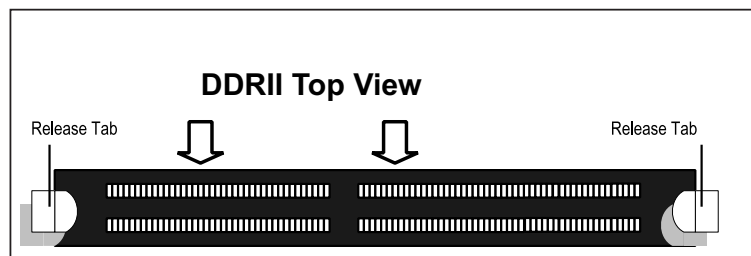
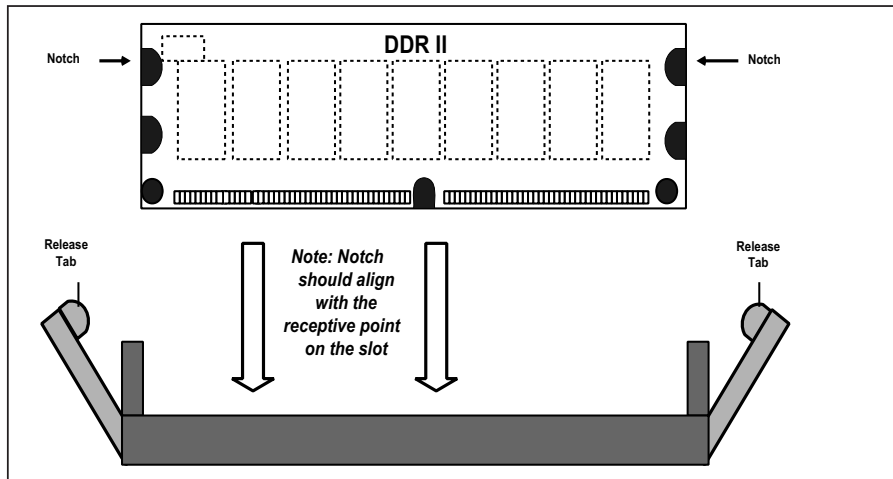
**To Remove:**

Use your thumbs to gently push near the edge of both ends of the module. This should release it from the slot.

2-4 I/O Ports/Control Panel Connectors

The I/O ports are color coded in conformance with the PC 99 specification. See Figure 2-3 below for the colors and locations of the various I/O ports.

Figure 2-3. I/O Port Locations and Definitions

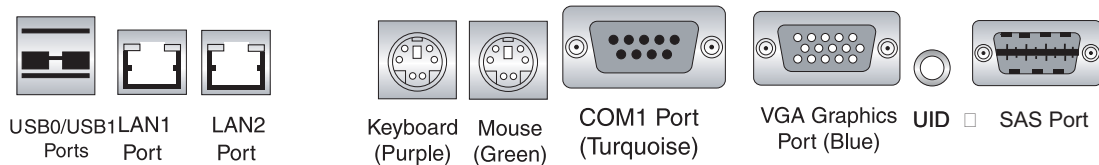

Front Control Panel

JF1 contains header pins for various buttons and indicators that are normally located on a control panel at the front of the chassis. These connectors are designed specifically for use with Supermicro server chassis. See Figure 2-4 for the descriptions of the various control panel buttons and LED indicators. Refer to the following section for descriptions and pin definitions.

Figure 2-4. JF1 Header Pins

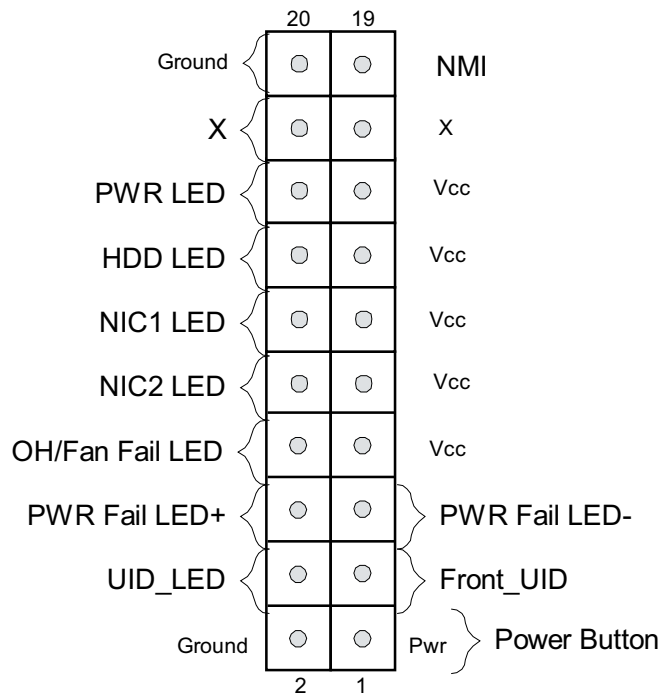

2-5 Connecting Cables

ATX Power Connector

The main power supply connector (JPW1) on the X6DHP-3G2 meets the SSI (Superset ATX) specification. You can only use a 20-pin power supply cable on the motherboard. Make sure that the orientation of the connector is correct.

ATX Power 20-pin Connector Pin Definitions (ATX)			
Pin#	Definition	Pin #	Definition
11	GND8	1	GND1
12	+5V1	2	GND2
13	+5V2	3	GND3
14	3.3V1	4	GND4
15	3.3V2	5	GND5
16	+5V/SB	6	GND6
17	+12V4	7	GND7
18	+12V5	8	+12V1
19	+12V6	9	+12V2
20	Blcked	10	+12V3

Secondary Power Connector

In addition to the Primary ATX power connector (above), the 9-pin Secondary Power Connector at JPWR1 must also be connected to your power supply for Secondary power consumption to avoid power-up failure.

9-pin Power Connector Pin Definitions			
Pin#	Definition	Pin#	Definition
1	SMB_CLK	2	GND
3	SMB_DATA	4	PWR_Fail
5	GND	6	PWR_OK
7	PWR_ON	8	-12V
9	NC	X	Key

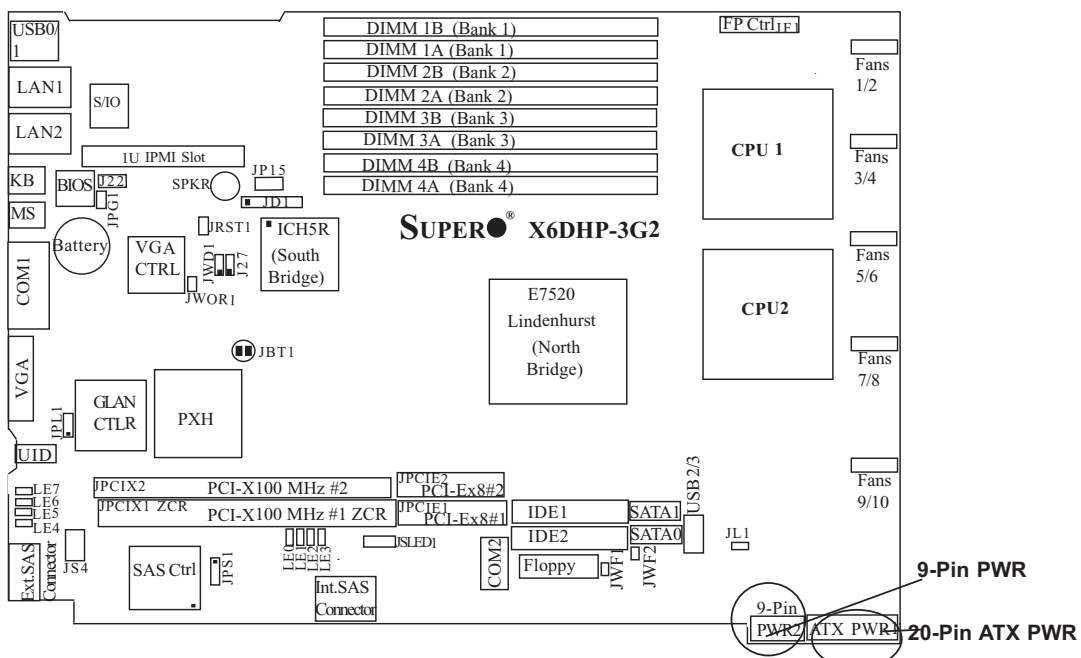

NMI Button

The non-maskable interrupt button header is located on pins 19 and 20 of JF1. Refer to the table on the right for pin definitions.

NMI Button Pin Definitions (JF1)	
Pin#	Definition
19	Control
20	Ground

Power LED

The Power LED connection is located on pins 15 and 16 of JF1. Refer to the table on the right for pin definitions.

Power LED Pin Definitions (JF1)	
Pin#	Definition
15	+5V
16	Ground

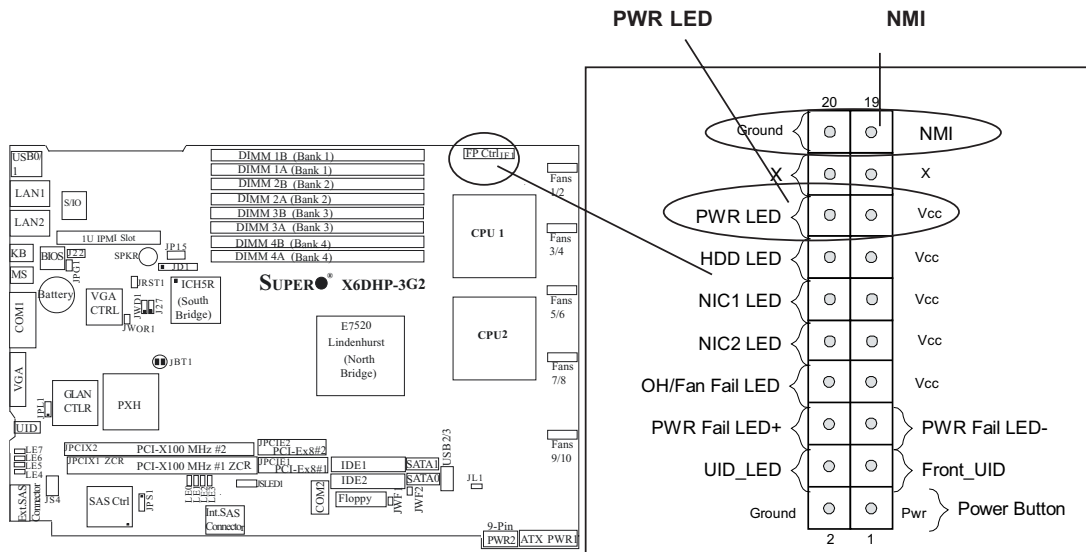

HDD LED

The HDD LED connection is located on pins 13 and 14 of JF1. Attach the hard drive LED cable here to display disk activity (for any hard drives on the system, including SCSI, Serial ATA and IDE). See the table on the right for pin definitions.

HDD LED Pin Definitions (JF1)	
Pin#	Definition
13	+5V
14	HD Active

NIC1/NIC2 LED Indicators

The NIC (Network Interface Controller) LED connections for the GLAN port1 is located on pins 11 and 12 of JF1, and for the GLAN port2 is located on pins 9 and 10 of JF1. Attach the NIC LED cables to display network activity. Refer to the tables on the right for pin definitions.

GLAN1/2 LED Pin Definitions (JF1)	
Pin#	Definition
9/11	Vcc
11/12	Ground

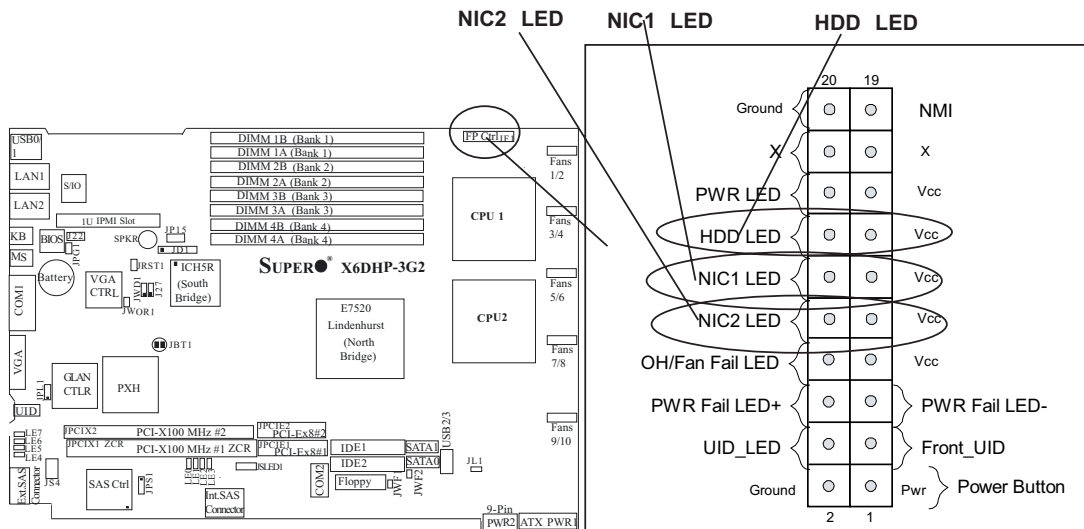

Overheat/Fan_Fail LED

Connect an LED to the OH/Fan Fail connection on pins 7 and 8 of JF1 to provide advanced warning of chassis overheating or system fan failure. Refer to the table on the right for pin definitions.

OH/Fan Fail LED Pin Definitions (JF1)	
Pin#	Definition
7	Vcc
8	Ground

OH/Fan Fail Indicator Status	
State	Definition
Off	Normal
On	Overheat
Flashing	Fan Fail

PWR Fail LED

The Power Fail LED connection is located on pins 5 and 6 of JF1. Refer to the tables on the right for pin definitions and color messages.

PWR Fail LED Pin Definitions (JF1)	
Pin#	Definition
5	Vcc
6	Ground

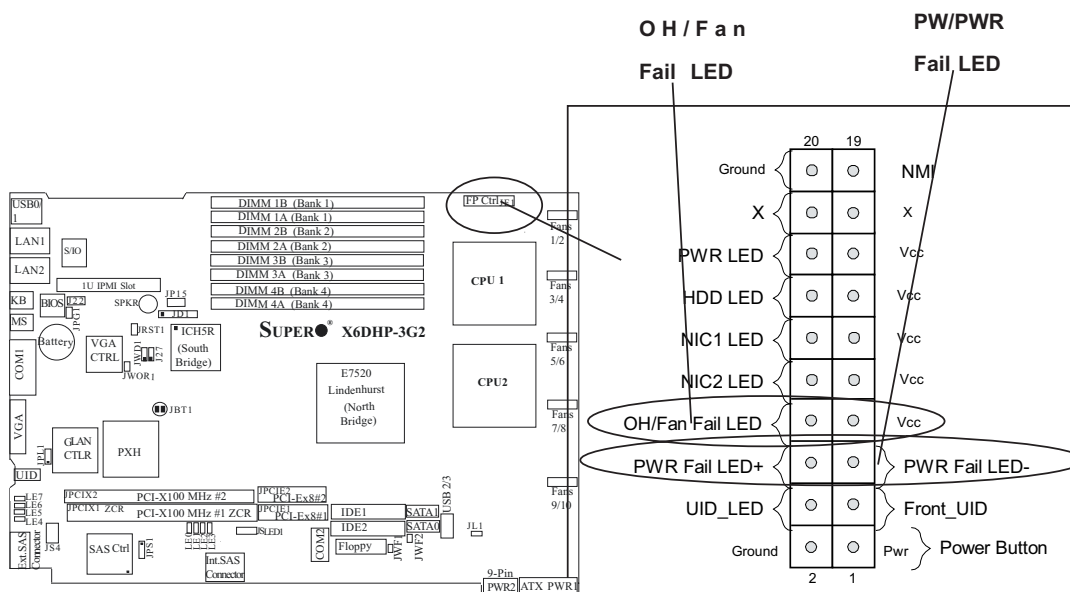

Front_UID Button/ UID_LED

There is a Universal Indicator located next to the VGA Connector on the motherboard. The Front_UID Button/UID_LED connection is located on pins 3 and 4 of JF1. Refer to the table on the right for pin definitions.

UID & UID_LED Pin Definitions (JF1)	
Pin#	Definition
3	Front UID Button
4	UID_LED

Power Button

The Power Button connection is located on pins 1 and 2 of JF1. Momentarily contacting both pins will power on/off the system. This button can also be configured to function as a suspend button (with a setting in BIOS - see Chapter 4). To turn off the power when set to suspend mode, depress the button for at least 4 seconds. Refer to the table on the right for pin definitions.

Power Button Pin Definitions (JF1)	
Pin#	Definition
1	Signal
2	+3V Standby

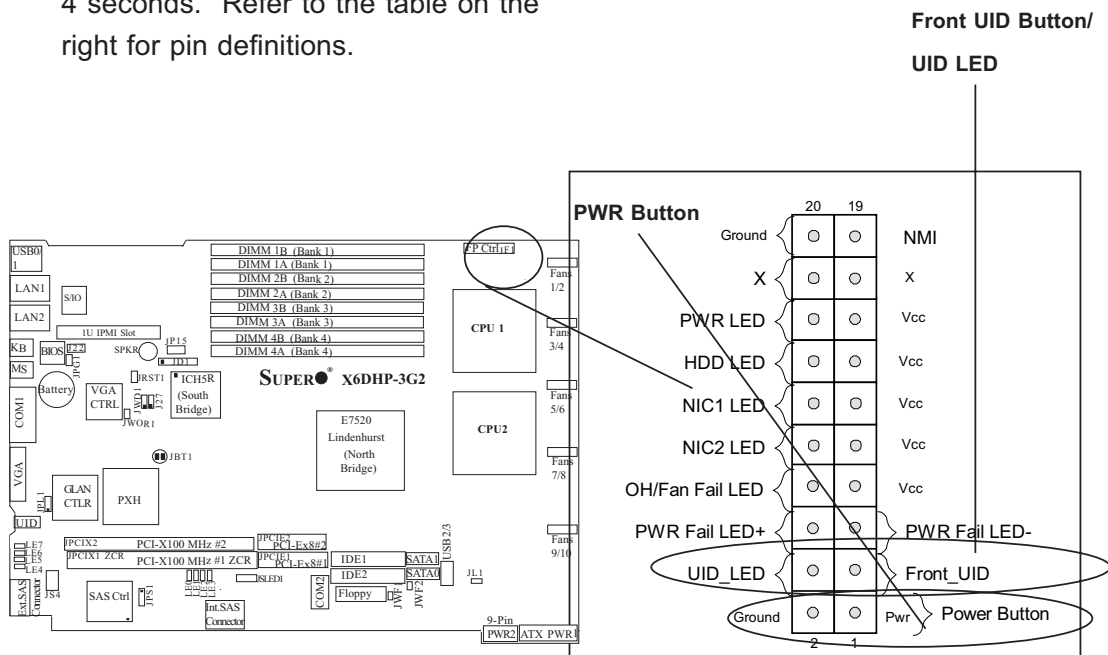

Chassis Intrusion

A Chassis Intrusion header is located at JL1. Attach the appropriate cable to inform you of a chassis intrusion.

Chassis Intrusion Pin Definitions (JL1)	
Pin#	Definition
1	Intrusion Input
2	Ground

Serial Ports

There are two COM headers (JCOM1 and JCOM2) located between SCSI Channel A and IDE Drives. See the table on the right for pin definitions.

Serial Port Pin Definitions (COM1/COM2)			
Pin #	Definition	Pin #	Definition
1	CD	6	DSR
2	RD	7	RTS
3	TD	8	CTS
4	DTR	9	RI
5	Ground	10	NC

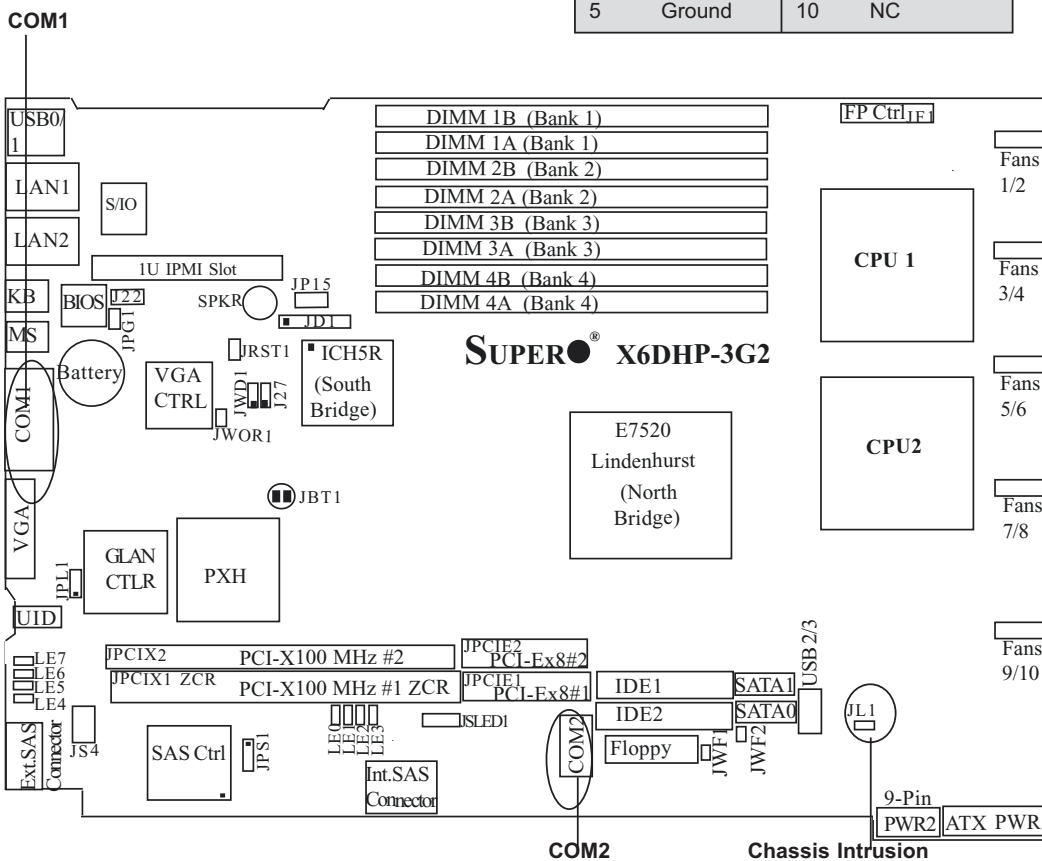

Universal Serial Bus (USB0/1)

Two USB 2.0 ports (JUSB1) are located beside the GLAN1 port. USB0 is the bottom connector and USB1 is the top connector. An Extra USB header: JUSB2 (USB2/USB3) can be used for front side USB access. You will need a USB cable to use the connections. Refer to the tables on the right for pin definitions. See the table on the right for pin definitions.

Universal Serial Bus Pin Definitions			
USB 0/1 Pin #	Definition	(FP) Pin #	USB 2/3 Definition
1	+5V	1	+5V
2	PO-	2	PO-
3	PO+	3	PO+
4	Ground	4	Ground
5	N/A	5	Key

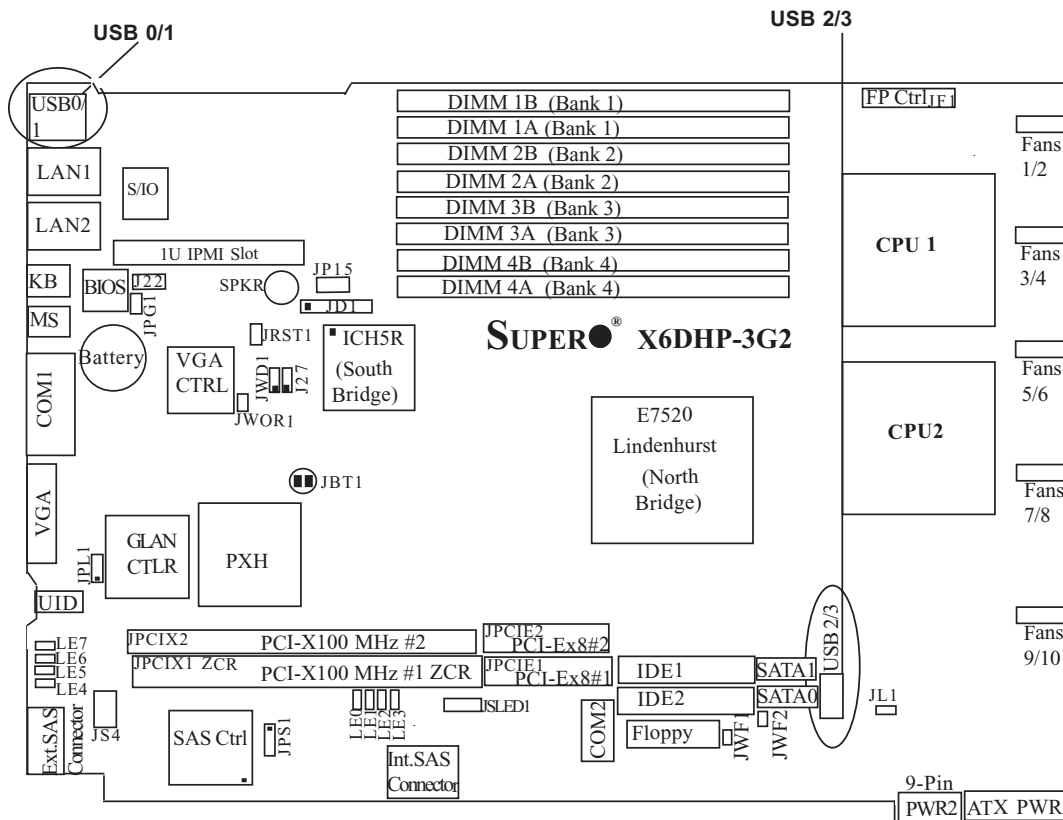

GLAN (Giga-bit Ethernet Ports)



Two G-bit Ethernet ports (designated LAN1/LAN2) are located next to the USB 0/1 ports. This port accepts RJ45 type cables.

ATX PS/2 Keyboard and PS/2 Mouse Ports

The ATX PS/2 keyboard and PS/2 mouse are located next to the COM1 connector. See the table at right for pin definitions. (See Figure 2-3 for the locations of each.)

Pin#	Definition
1	Data
2	NC
3	Ground
4	VCC
5	Clock
6	NC

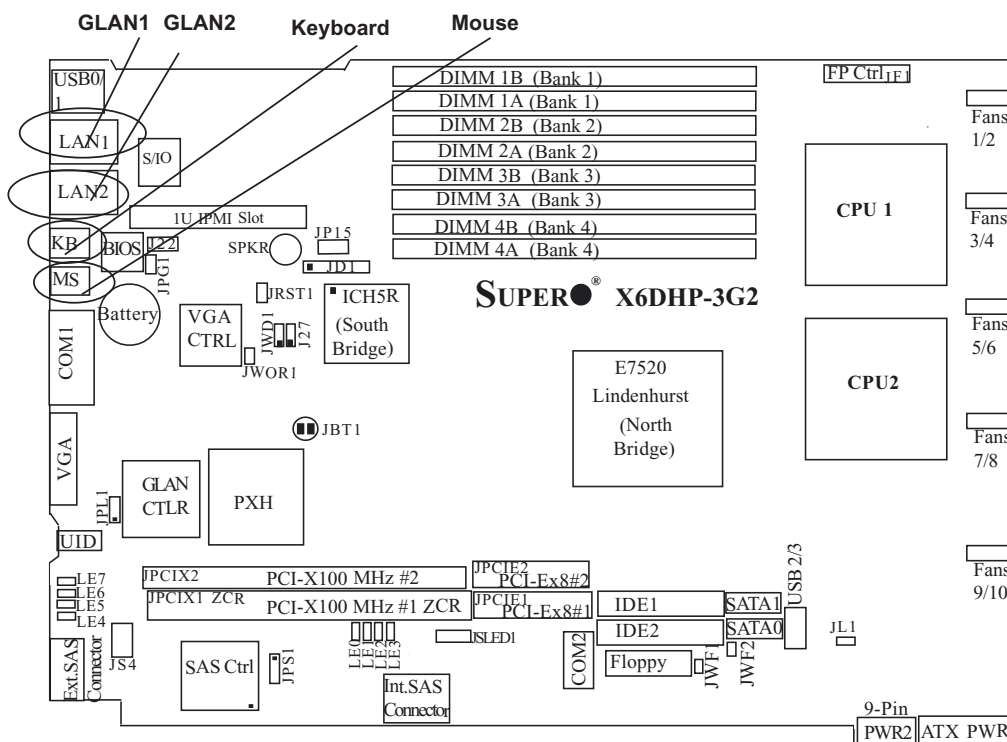

Fan Headers

The X6DHP-3G2 has ten fan headers (Fan1 to Fan10). These fan headers use DC Power. *Note: please be sure to use Supermicro's Fan (P/N: Fan-0079) on the motherboard. See the table on the right for pin definitions.

Fan Header Pin Definitions		
Definition	Pin#	Color
Fan PWR	1	Red
Tachometer	2	Yellow
GND	3	Black
GND	4	Grey
Tachometer	5	White
Fan PWR	6	Orange

Power LED/Speaker

On the JDI header, pins 1-3 are for a power LED and pins 4-7 are for the speaker. See the table on the right for speaker pin definitions. Note: The speaker connector pins are for use with an external speaker. If you wish to use the onboard speaker, you should close pins 6-7 with a jumper.

Speaker Connector	
Pin Setting	Definition
Pins 6-7	Internal Speaker
Pins 4-7	External Speaker

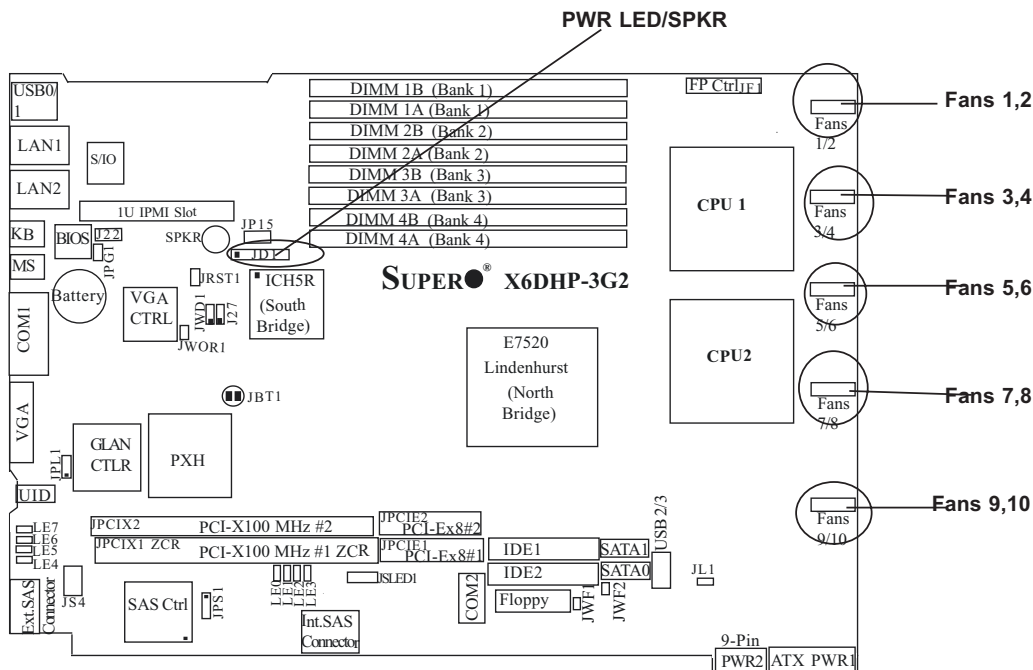

Wake-On-Ring

The Wake-On-Ring header is designated JWOR1. This function allows your computer to receive and "wake-up" by an incoming call to the modem when in suspend state. See the table on the right for pin definitions. You must have a Wake-On-Ring card and cable to use this feature.

Wake-On-Ring Pin Definitions (JWOR1)	
Pin#	Definition
1	Ground (Black)
2	Wake-up

Alarm Reset

The system will notify you in the event of a power supply failure. This feature assumes that Supermicro redundant power supply units are installed in the chassis. If you only have a single power supply installed, you should leave the pins open (the default setting) to prevent false alarms. See the table on the right for jumper settings.

Alarm Reset Pin Definitions	
Jumper Position	Definition
Open	Normal (*Default)
Short	Clear Alarm

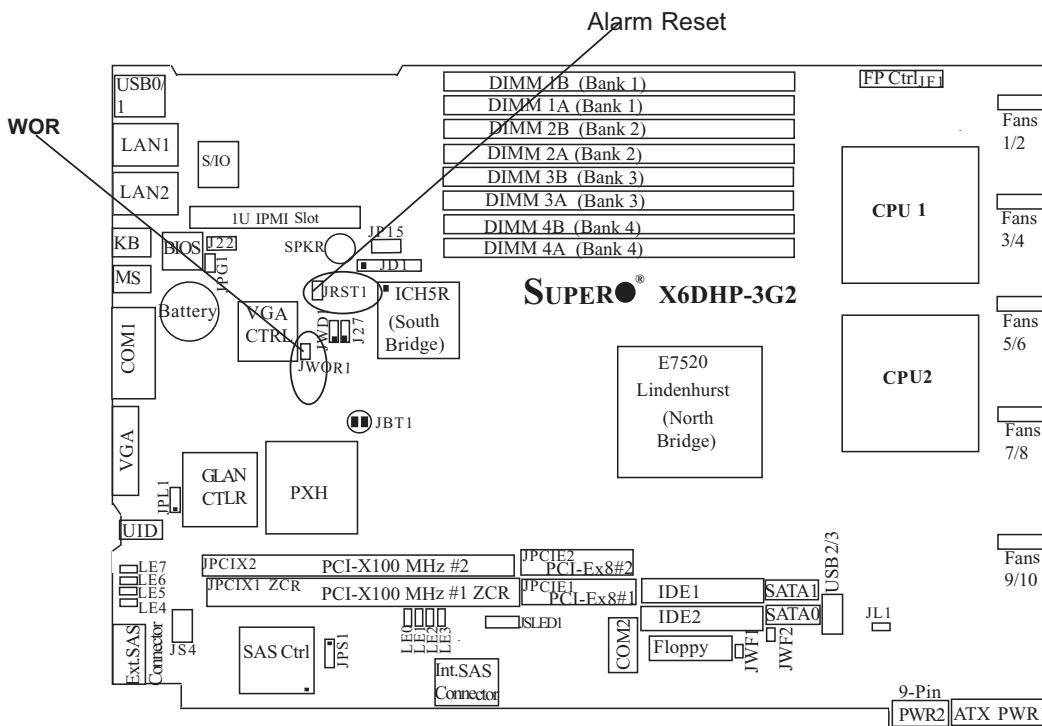

SMB

A System Management Bus header is located at J22. Connect the appropriate cable here to utilize SMB on your system.

SMB Header Pin Definitions	
Pin#	Definition
1	Data
2	Ground
3	Clock
4	No Connection

Power SMB (I²C) Connector

I²C Connector (JS4), located next to the External SAS Connector monitors the status of PWR Supply, Fan and system temperature.

SMB PWR Header Pin Definitions	
Pin#	Definition
1	Clock
2	Data
3	PWR Fail
4	Ground
5	+3.3V

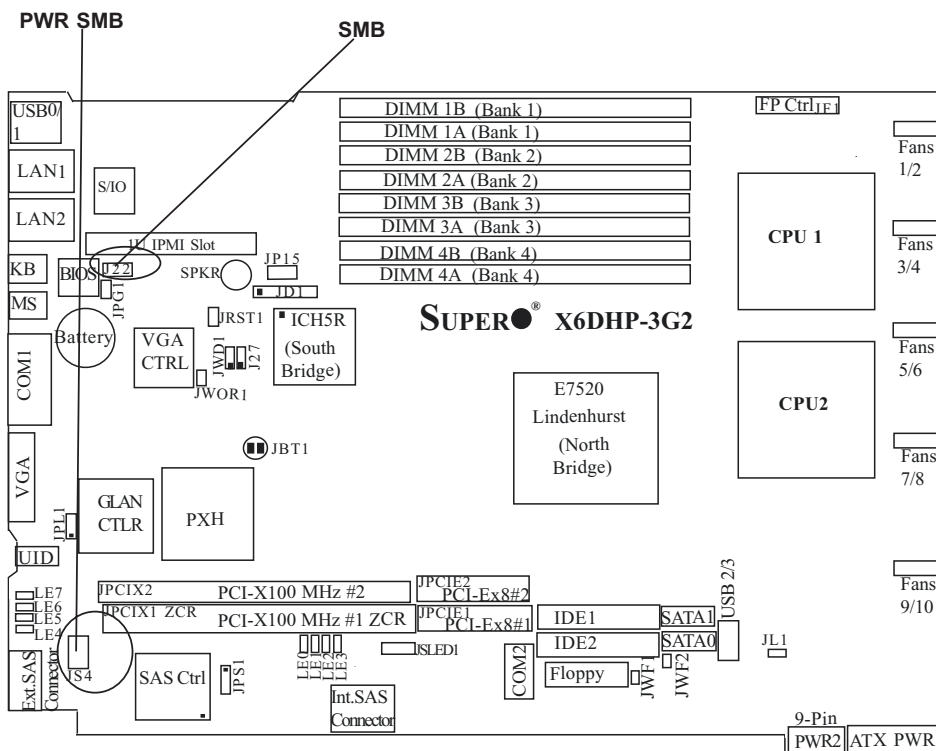

2-6 Jumper Settings

Explanation of Jumpers

To modify the operation of the motherboard, jumpers can be used to choose between optional settings. Jumpers create shorts between two pins to change the function of the connector. Pin 1 is identified with a square solder pad on the printed circuit board. See the motherboard layout pages for jumper locations.

Note: On two pin jumpers, "Closed" means the jumper is on and "Open" means the jumper is off the pins.

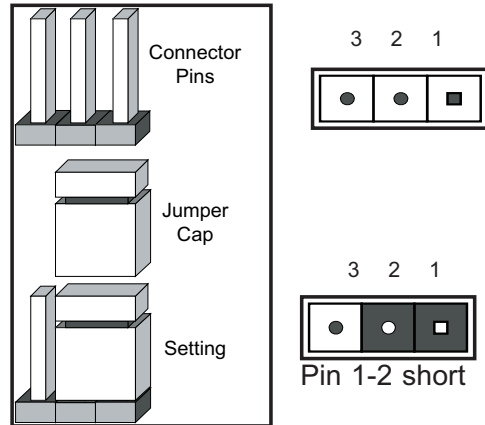

GLAN Enable/Disable

JPL1 enables or disables the GLAN ports on the motherboard. See the table on the right for jumper settings. The default setting is enabled.

GLAN Enable Jumper Settings	
Jumper Setting	Definition
Pins 1-2	Enabled
Pins 2-3	Disabled

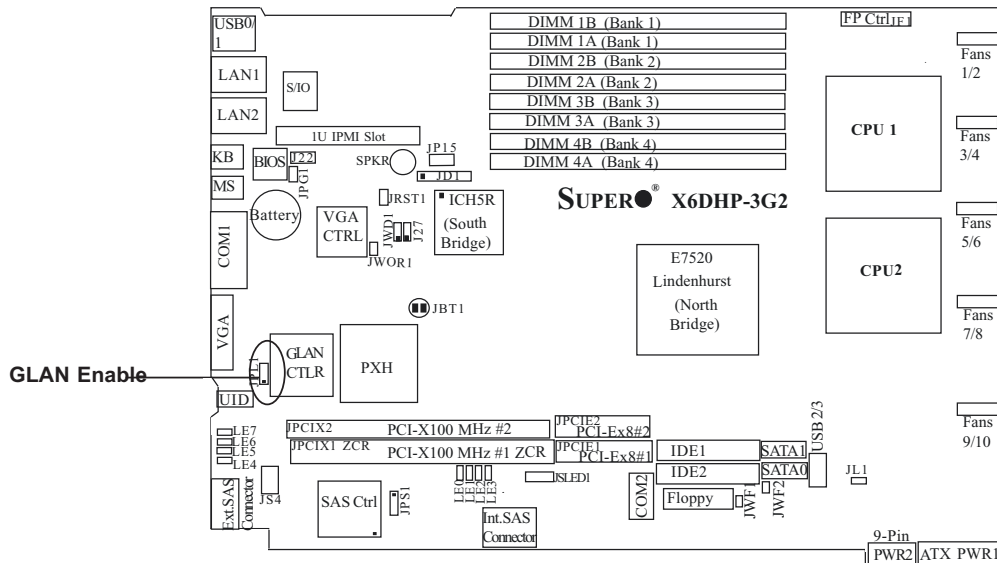

CMOS Clear

JBT1 is used to clear CMOS. Instead of pins, this "jumper" consists of contact pads to prevent the accidental clearing of CMOS. To clear CMOS, use a metal object such as a small screwdriver to touch both pads at the same time to short the connection. Always remove the AC power cord from the system before clearing CMOS.



Note: For an ATX power supply, you must completely shut down the system, remove the AC power cord and then short JBT1 to clear CMOS. ***Do not use the PW_ON connector to clear CMOS.***

SAS Enable/Disable

JPS1 enables or disables the SAS Controller on the motherboard. The default setting is pins 1-2 to enable all four headers. See the table on the right for jumper settings. The default setting is enabled.

SAS Enable/Disable Jumper Settings	
Jumper Setting	Definition
Pins 1-2	Enabled
Pins 2-3	Disabled

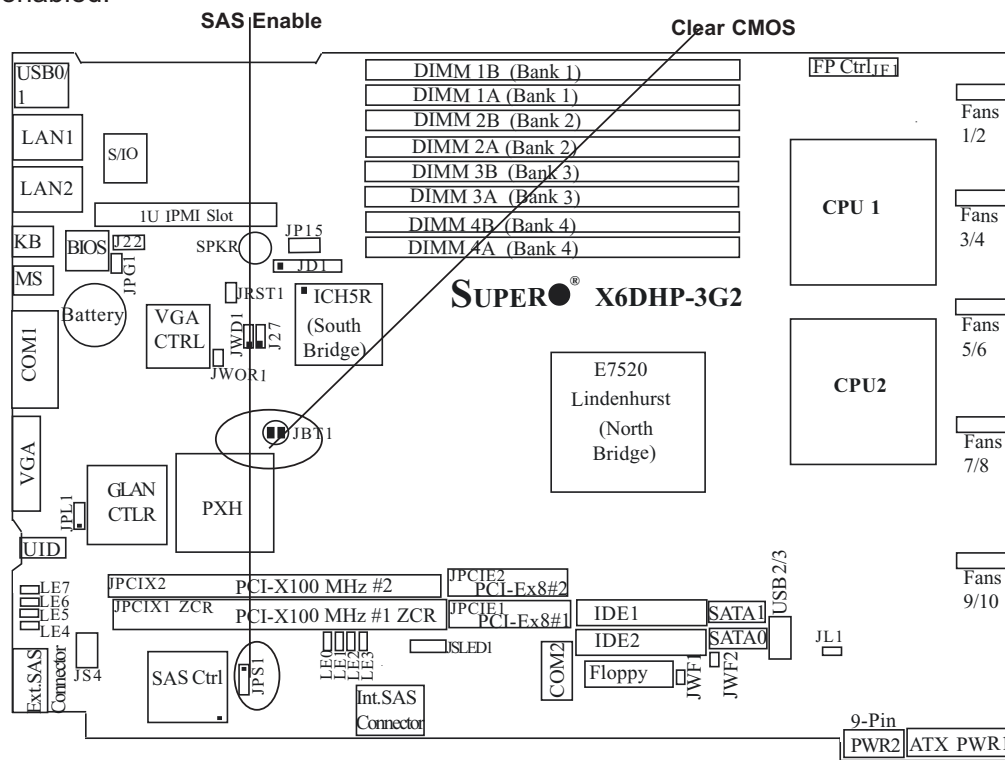

VGA Enable/Disable

JPG1 enables or disables the VGA Connector on the motherboard. See the table on the right for jumper settings. The default setting is enabled.

VGA Enable/Disable Jumper Settings	
Jumper Setting	Definition
Pins 1-2	Enabled
Pins 2-3	Disabled

Watch Dog Enable

JWD1 controls Watch Dog, a system monitor that takes action when a software application freezes the system. Pins 1-2 will have WD reset the system if a program freezes. Pins 2-3 will generate a non-maskable interrupt for the program that has frozen (requires software implementation). Watch Dog must also be enabled in BIOS.

Watch Dog Jumper Settings (JWD)	
Jumper Setting	Definition
Pins 1-2	Reset
Pins 2-3	NMI
Open	Disabled

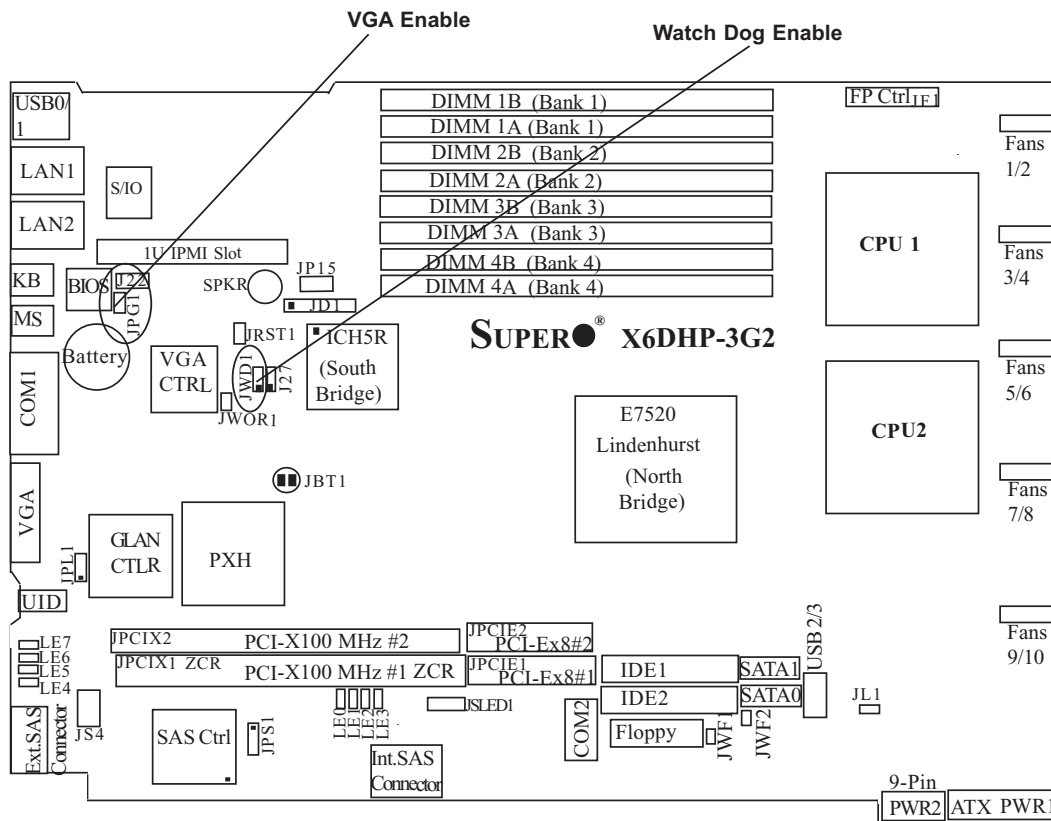

2-7 Onboard Indicators

GLAN LEDs

Each of the Gigabit Ethernet LAN ports (LAN1/LAN2) has two LEDs on the back of the connectors. The yellow LED indicates activity while the other LED may be green, orange or off to indicate the speed of the connection. See the table at right for the functions associated with the second LED.

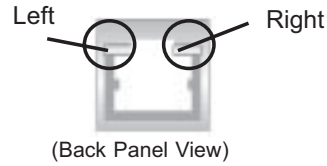

GLAN Left LED Connection Speed Indicator	
LED Color	Definition
Off	10Mbps or No Connection
Green	100 Mbps
Amber	1 Gbps

GLAN Right LED Connection Speed Indicator	
LED Color	Definition
Amber	Flashing: 10Mbps/ 100Mbps/1 Gbps

SAS Activity LED Indicators

SAS Activity LED Indicators (LE0-LE3) indicate the activity status of Internal SAS Connector (JSM2), and SAS Activity LED Indicators (LE4-7) indicate the activity status of External SAS Connector (JSM1). See the table on the right for pin definitions.

SAS_ACT_Output (DS1-DS8) Definitions			
DS#	Definition	DS#	Definition
LE0	SAS0:Act	LE4	SAS4:Act
LE1	SAS1:Act	LE5	SAS5:Act
LE2	SAS2:Act	LE6	SAS6:Act
LE3	SAS3:Act	LE7	SAS7:Act

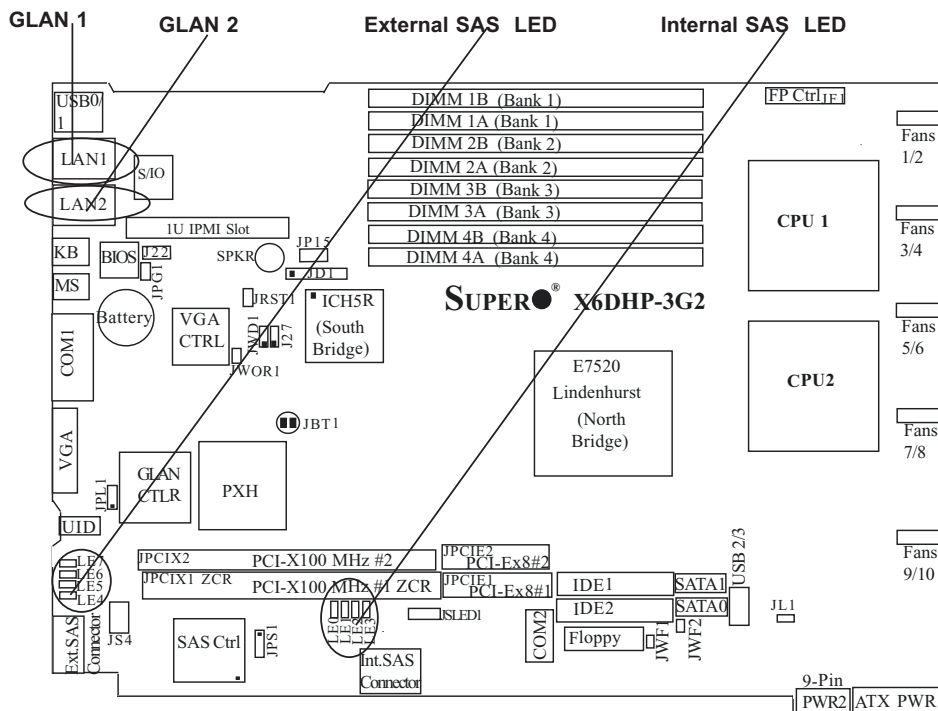

Unit Identification Indicators

There are two Unit Identification (UID) Indicators on the motherboard. The Front Panel (FP) UID is connected to the Front Control Panel. The Back Panel (BP) UID Indicator (UID1) is located between External SAS Connector and the VGA Connector. When you push the UID button on the Front Control Panel, both BP UID and FP UID Indicators will be activated. Push the UID button again to turn off both Indicators. These UID Indicators provide easy identification of a system unit that may be in need of service.

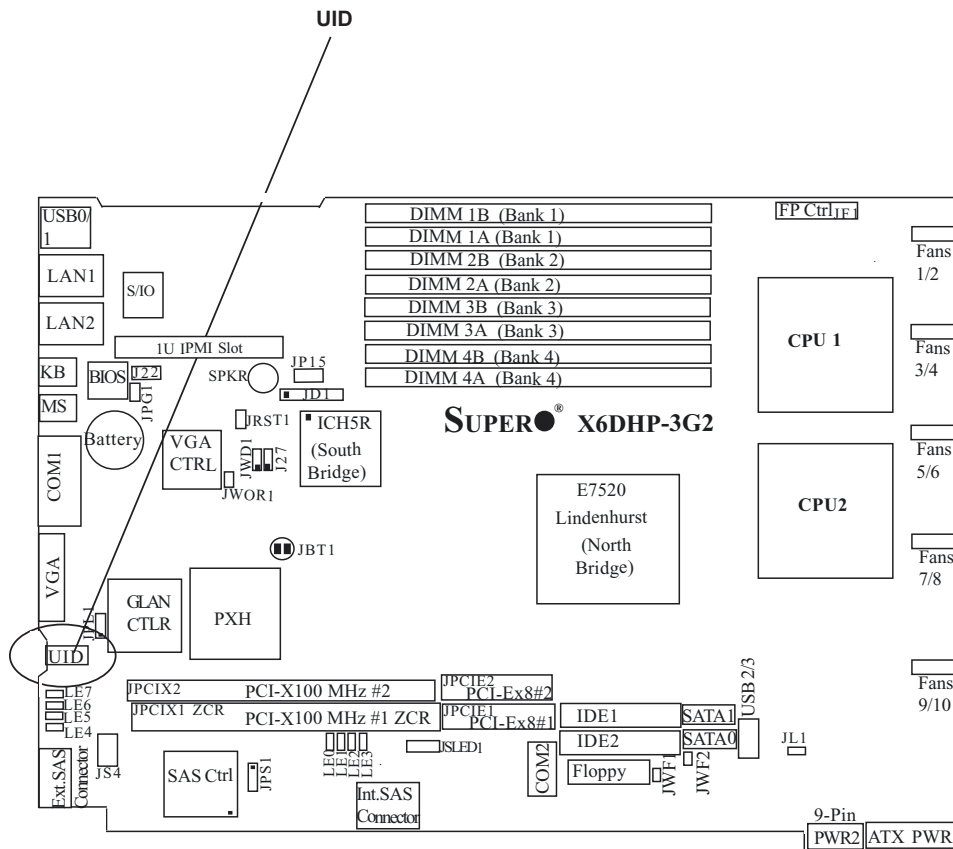

2-8 Floppy Drive, Hard Disk Drive and IPMI Connections

Note the following when connecting the floppy and hard disk drive cables:

- The floppy disk drive cable has seven twisted wires.
- A red mark on a wire typically designates the location of pin 1.
- A single floppy disk drive ribbon cable has 34 wires and two connectors to provide for two floppy disk drives. The connector with twisted wires always connects to drive A, and the connector that does not have twisted wires always connects to drive B.

Floppy Connector

The floppy connector is located next to the IDE connectors. See the table below for pin definitions.

Floppy Drive Connector Pin Definitions (Floppy)			
Pin#	Definition	Pin #	Definition
1	Ground	2	FDHDIN
3	Ground	4	Reserved
5	Key	6	FDEDIN
7	Ground	8	Index
9	Ground	10	Motor Enable
11	Ground	12	Drive Select B
13	Ground	14	Drive Select B
15	Ground	16	Motor Enable
17	Ground	18	DIR
19	Ground	20	STEP
21	Ground	22	Write Data
23	Ground	24	Write Gate
25	Ground	26	Track 00
27	Ground	28	Write Protect
29	Ground	30	Read Data
31	Ground	32	Side 1 Select
33	Ground	34	Diskette

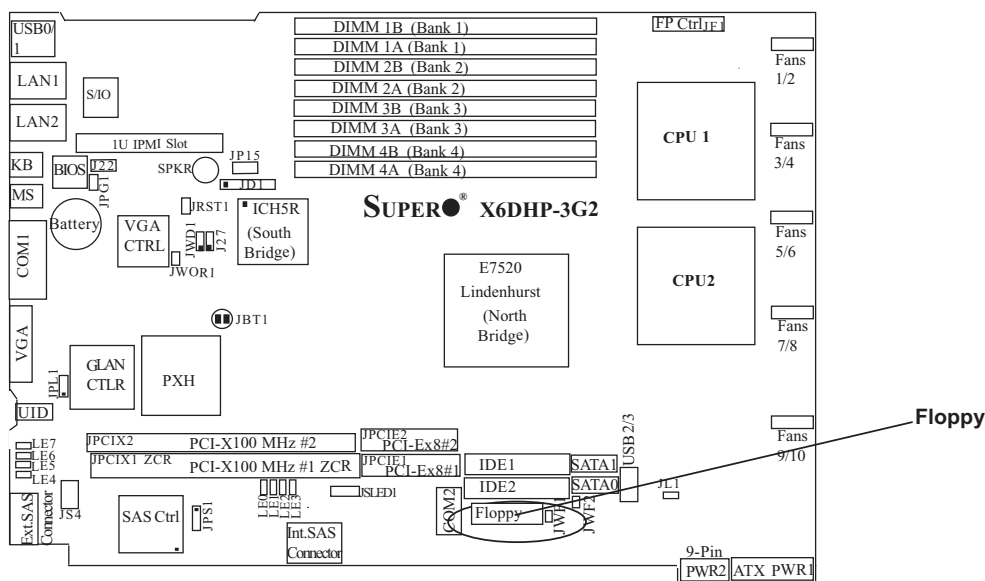

IDE Connectors

There are no jumpers to configure the onboard IDE#1 and #2 connectors (at JIDE1 and JIDE2, respectively). See the table on the right for pin definitions.

IDE Drive Connectors Pin Definitions (IDE)			
Pin#	Definition	Pin #	Definition
1	Reset IDE	2	Ground
3	Host Data 7	4	Host Data 8
5	Host Data 6	6	Host Data 9
7	Host Data 5	8	Host Data 10
9	Host Data 4	10	Host Data 11
11	Host Data 3	12	Host Data 12
13	Host Data 2	14	Host Data 13
15	Host Data 1	16	Host Data 14
17	Host Data 0	18	Host Data 15
19	Ground	20	Key
21	DRQ3	22	Ground
23	I/O Write	24	Ground
25	I/O Read	26	Ground
27	IOCHRDY	28	BALE
29	DACK3	30	Ground
31	IRQ14	32	IOCS16
33	Addr1	34	Ground
35	Addr0	36	Addr2
37	Chip Select 0	38	Chip Select 1
39	Activity	40	Ground

1U IPMI

There is an 1U IPMI Socket on the motherboard. Refer to the layout below for the IPMI Socket location.

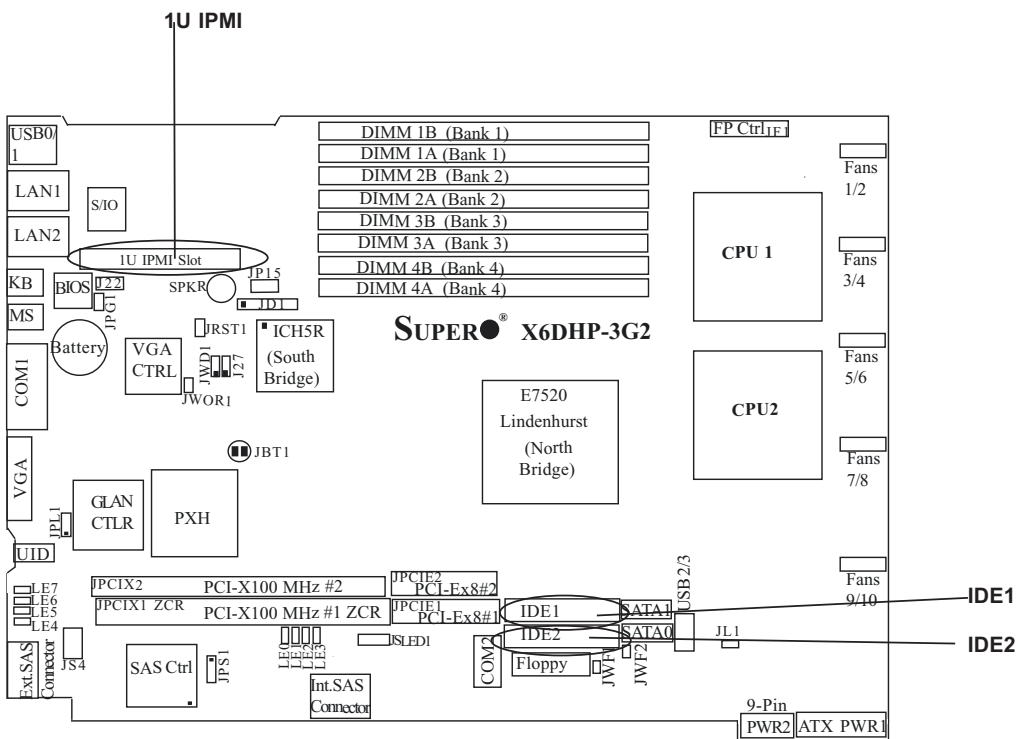

Chapter 3

Troubleshooting

3-1 Troubleshooting Procedures

Use the following procedures to troubleshoot your system. If you have followed all of the procedures below and still need assistance, refer to the 'Technical Support Procedures' and/or 'Returning Merchandise for Service' section(s) in this chapter.

Note: Always disconnect the power cord before adding, changing or installing any hardware components.

Before Power On

1. Make sure that there is not any short circuit between the motherboard and chassis.
2. Disconnect all ribbon/wire cables from the motherboard, including those for the keyboard and mouse.
3. Remove all add-on cards.
4. Properly install the CPU and make sure that the CPU is fully seated in the socket. Connect the chassis speaker and the power LED to the motherboard. (Check all jumper settings as well.)
5. Use only the correct type of CMOS onboard battery as recommended by the Manufacturer. Do not install the onboard battery upside down to avoid possible explosion.

No Power

1. Make sure that there is not any short circuit between the motherboard and the chassis.
2. Verify that all jumpers are set to their default positions.
3. Check that the 115V/230V switch on the power supply is properly set.
4. Turn the power switch on and off to test the system.
5. The battery on your motherboard may be old. Check to verify that it still supplies ~3VDC. If it does not, replace it with a new one.

No Video

1. If the power is on but you have no video, remove all the add-on cards and cables.
2. Use the speaker to determine if any beep codes exist. Refer to the Appendix for details on beep codes.

NOTE

If you are a system integrator, VAR or OEM, a POST diagnostics card is recommended. For I/O port 80h codes, refer to App. B.

Memory Errors

1. Make sure the DIMM modules are properly and fully installed.
2. Determine if different speeds of DIMMs have been installed and verify that the BIOS setup is configured for the fastest speed of RAM used. It is recommended to use the same RAM speed for all DIMMs in the system.
3. Make sure you are using the correct type of Registered ECC DDR-II 400 SDRAM (*Please refer to Page 2-5 for the instruction on DDR-II 400 DIMM population and installation.)
4. Check for bad DIMM modules or slots by swapping a single module between two slots and noting the results.
5. Make sure all memory modules are fully seated in their slots. As an interleaved memory scheme is used, you must install two modules at a time, beginning with Bank 1, then Bank 2, and so on (see Section 2-3).
6. Check the position of the 115V/230V switch on the power supply.

Losing the System's Setup Configuration

1. Ensure that you are using a high quality power supply. A poor quality power supply may cause the system to lose the CMOS setup information. Refer to Section 1-6 for details on recommended power supplies.
2. The battery on your motherboard may be old. Check to verify that it still supplies ~3VDC. If it does not, replace it with a new one.
3. If the above steps do not fix the Setup Configuration problem, contact your vendor for repairs.

3-2 Technical Support Procedures

Before contacting Technical Support, please take the following steps. Also, note that as a motherboard manufacturer, Super Micro does not sell directly to end-users, so it is best to first check with your distributor or reseller for troubleshooting services. They should know of any possible problem(s) with the specific system configuration that was sold to you.

1. Please go through the 'Troubleshooting Procedures' and 'Frequently Asked Question' (FAQ) sections in this chapter or see the FAQs on our web site (<http://www.supermicro.com/support/faqs/>) before contacting Technical Support.

2. BIOS upgrades can be downloaded from our web site at [\(http://www.supermicro.com/support/bios/\)](http://www.supermicro.com/support/bios/).

Note: Not all BIOS can be flashed depending on the modifications to the boot block code.

3. If you still cannot resolve the problem, include the following information when contacting Super Micro for technical support:

- Motherboard model and PCB revision number
- BIOS release date/version (this can be seen on the initial display when your system first boots up)
- System configuration

An example of a Technical Support form is on our web site at <http://www.supermicro.com/support/contact.cfm>.

4. Distributors: For immediate assistance, please have your account number ready when placing a call to our technical support department. We can be reached by e-mail at support@supermicro.com, by phone at: (408) 503-8000, option 2, or by fax at (408)503-8019.

3-3 Frequently Asked Questions

Question: What are the various types of memory that my motherboard can support?

Answer: The X6DHP-3G2 has eight 240-pin DIMM slots that support registered ECC DDR-II 400 SDRAM modules. It is strongly recommended that you do not mix memory modules of different speeds and sizes. (*In order to support 8 DIMMs, single rank memory modules must be used.)

Question: How do I update my BIOS?

Answer: It is recommended that you **do not** upgrade your BIOS if you are experiencing no problems with your system. Updated BIOS files are located on our web site at <http://www.supermicro.com>. Please check our BIOS warning message and the info on how to update your BIOS on our web site. Also, check the current BIOS revision and make sure it is newer than your BIOS before downloading. Select your motherboard model and download the BIOS file to your computer. Unzip the BIOS update file and you will find the readme.txt (flash instructions), the phlash.exe (BIOS flash utility), the platform.bin (platform file) and the BIOS image (xxxxxx.rom) files. Copy these files into a bootable floppy and reboot your system. Then, follow Readme.txt to continue flashing the BIOS.



(***Warning:** Do not shut down or reset the system while updating BIOS to prevent possible system boot failure!)

Question: What's on the CD that came with my motherboard?

Answer: The supplied compact disc has quite a few drivers and programs that will greatly enhance your system. We recommend that you review the CD and install the applications you need. Applications on the CD include chipset drivers for Windows and security and audio drivers.

3-4 Returning Merchandise for Service

A receipt or copy of your invoice marked with the date of purchase is required before any warranty service will be rendered. You can obtain service by calling your vendor for a Returned Merchandise Authorization (RMA) number. When returning to the manufacturer, the RMA number should be prominently displayed on the outside of the shipping carton, and mailed prepaid or hand-carried. Shipping and handling charges will be applied for all orders that must be mailed when service is complete.

This warranty only covers normal consumer use and does not cover damages incurred in shipping or from failure due to the alternation, misuse, abuse or improper maintenance of products.

During the warranty period, contact your distributor first for any product problems.

Chapter 4

BIOS

4-1 Introduction

This chapter describes the Phoenix BIOS™ Setup utility for the X6DHP-3G2. The Phoenix ROM BIOS is stored in a flash chip and can be easily upgraded using a floppy disk-based program.

Note: Due to periodic changes to the BIOS, some settings may have been added or deleted and might not yet be recorded in this manual. Please refer to the Manual Download area of the Supermicro web site <<http://www.supermicro.com>> for any changes to BIOS that may not be reflected in this manual.

System BIOS

The BIOS is the Basic Input Output System used in all IBM® PC, XT™, AT®, and PS/2® compatible computers. The Phoenix BIOS flash chip stores the system parameters, such type of disk drives, video displays, etc. in the CMOS. The CMOS memory requires very little electrical power. When the computer is turned off, a backup battery provides power to the BIOS flash chip, enabling it to retain system parameters. Each time the computer is powered-on the computer is configured with the values stored in the BIOS ROM by the system BIOS, which gains control at boot-up.

How To Change the Configuration Data

The CMOS information that determines the system parameters may be changed by entering the BIOS Setup utility. This Setup utility can be accessed by pressing the <Delete> key at the appropriate time during system boot, see below.

Starting the Setup Utility

Normally, the only visible POST (Power On Self Test) routine is the memory test. As the memory is being tested, press the <Delete> key to enter the main menu of the BIOS Setup utility. From the main menu, you can access the other setup screens, such as the Security and Power menus. Beginning with Section 4-3, detailed descriptions are given for each parameter setting in the Setup utility.

4-2 Running Setup

**Default settings are in bold text unless otherwise noted.*

The BIOS setup options described in this section are selected by choosing the appropriate text from the main BIOS Setup screen. All displayed text is described in this section, although the screen display is often all you need to understand how to set the options (see on next page).

When you first power on the computer, the Phoenix BIOS™ is immediately activated.

While the BIOS is in control, the Setup program can be activated in one of two ways:

1. By pressing <Delete> immediately after turning the system on, or
2. When the message shown below appears briefly at the bottom of the screen during the POST (Power On Self-Test), press the <Delete> key to activate the main Setup menu:

Press the <Delete> key to enter Setup

(*Note: Please load "System Setup Default" when using the system the first time.)

4-3 Main BIOS Setup

All main Setup options are described in this section. The main BIOS Setup screen is displayed below.

Use the Up/Down arrow keys to move among the different settings in each menu. Use the Left/Right arrow keys to change the options for each setting.

Press the <Esc> key to exit the CMOS Setup Menu. The next section describes in detail how to navigate through the menus.

Items that use submenus are indicated with the ► icon. With the item highlighted, press the <Enter> key to access the submenu.

Main BIOS Setup Menu

PhoenixBIOS Setup - Copyright 1985-2004 Phoenix Technologies Ltd.				
Main	Advanced	Security	Boot	Exit
System Time:	[17:47:12]	Item Specific Help <Tab>, <Shift-Tab>, or <Enter> selects field.		
System Date:	[08-22-2005]			
BIOS Date				
Legacy Diskette A:	[1.44/1.25 MB 3½"]			
Parallel ATA:	[Both]			
Serial ATA:	[Enabled]			
SATA RAID Enable	[Disabled]			
Native Mode Operation:	[Auto]			
▶ IDE Channel 0 Master				
▶ IDE Channel 0 Slave				
▶ IDE Channel 1 Master				
▶ IDE Channel 1 Slave				
▶ IDE Channel 2 Master				
▶ IDE Channel 3 Master				
System Memory:	[XXXX KB]			
Extended Memory:	[XXXX KB]			
F1 Help ↑↓ Select Item -/+ Change Values F9 Setup Defaults Esc Exit ←→ Select Menu Enter Select ▶ Sub-Menu F10 Previous Values				

Main Setup Features

System Time

To set the system date and time, key in the correct information in the appropriate fields. Then press the <Enter> key to save the data.

System Date

Using the arrow keys, highlight the month, day and year fields and enter the correct data. Press the <Enter> key to save the data.

BIOS Date

This feature allows BIOS to automatically display the BIOS date.

Legacy Diskette A

This setting allows the user to set the type of floppy disk drive installed as diskette A. The options are Disabled, 360Kb 5.25 in, 1.2MB 5.25 in, 720Kb 3.5 in, **1.44/1.25MB, 3.5 in** and 2.88MB 3.5 in.

Parallel ATA

This setting allows the user to enable or disable the function of Parallel ATA. The options are Disabled, Channel 0, Channel 1 and **Both**.

Serial ATA

This setting allows the user to enable or disable the function of Serial ATA. The options are Disabled and **Enabled**.

Serial ATA RAID Enable

Select Enable to enable Serial ATA RAID Functions. (*For the OS environment, use the RAID driver if this feature is set to Enabled.) The options are **Disabled** and Enabled.

Native Mode Operation

This option allows the user to select the Native Mode Operation for ATA. The options are: Parallel ATA, Serial ATA, Both, and **Auto**.

► IDE Channel 0 Master/Slave, IDE Channel 1 Master/Slave, IDE Channel 2 Master, IDE Channel 3 Master

These settings allow the user to set the parameters of IDE Channel 0 Master/Slave, IDE Channel 1 Master/Slave, IDE Channel 2 Master, IDE Channel 3 Master slots. Hit <Enter> to activate the following sub-menu screen for detailed options of these items. Set the correct configurations accordingly. The items included in the sub-menu are:

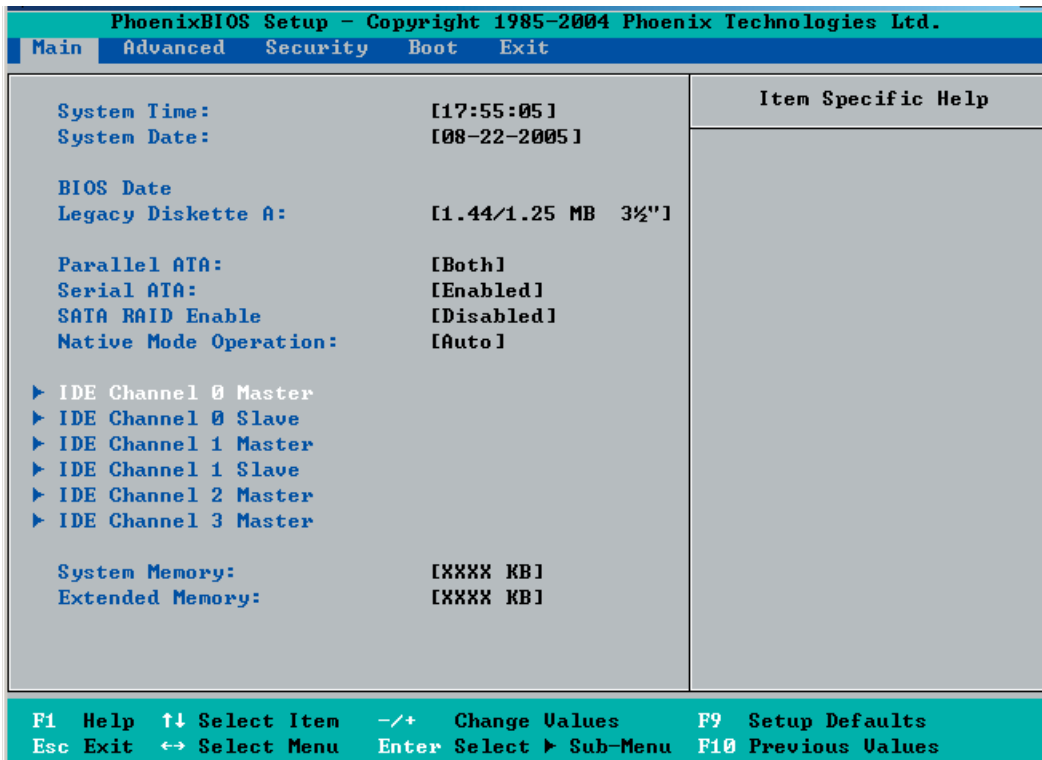

Type

This setting allows the user to select the type of IDE hard drive. The options are **Auto**, (which allows BIOS to automatically determine the hard drive's capacity, number of heads, etc.), a number from 1-39 to select a predetermined type of hard drive, CDROM and ATAPI Removable. The option- "User" will allow the user to enter the parameters of the HDD installed at this connection. The option-"Auto" will allow BIOS to automatically configure the parameters of the HDD installed at the connection. Choose the option 1-39 to select a predetermined HDD type. Select CDROM if a CDROM drive is installed. Select ATAPI if a removable disk drive is installed.

Multi-Sector Transfer

This item allows the user to specify the number of sectors per block to be used in multi-sector transferring. The options are Disabled, 4 Sectors, 8 Sectors and **16 Sectors**.

LBA Mode Control

This item determines if the Phoenix BIOS will access the IDE Channel 0 Master Device via the LBA mode. The options are **Enabled** and Disabled.

32 Bit I/O

This option allows the user to enable or disable the function of 32-bit data transfer. The options are Enabled and **Disabled**.

Transfer Mode

This option allows the user to select the transfer mode. The options are **Standard**, Fast PIO1, Fast PIO2, Fast PIO3, Fast PIO4, FPIO3/DMA1 and FPIO4/DMA2.

Ultra DMA Mode

This option allows the user to select the Ultra DMA Mode. The options are **Disabled**, Mode 0, Mode 1, Mode 2, Mode 3, Mode 4 and Mode 5.

System Memory

This display informs you how much system memory is recognized and detected by the OS in the system.

Extended Memory

This display informs you how much extended memory is recognized and detected by the OS in the system.

4-4 Advanced Setup

Choose Advanced from the Phoenix BIOS Setup Utility main menu with the arrow keys. You should see the following display. The items with a triangle beside them have sub menus that can be accessed by highlighting the item and pressing <Enter>. Options for PIR settings are displayed by highlighting the setting option using the arrow keys and pressing <Enter>. All Advanced BIOS Setup options are described in this section.

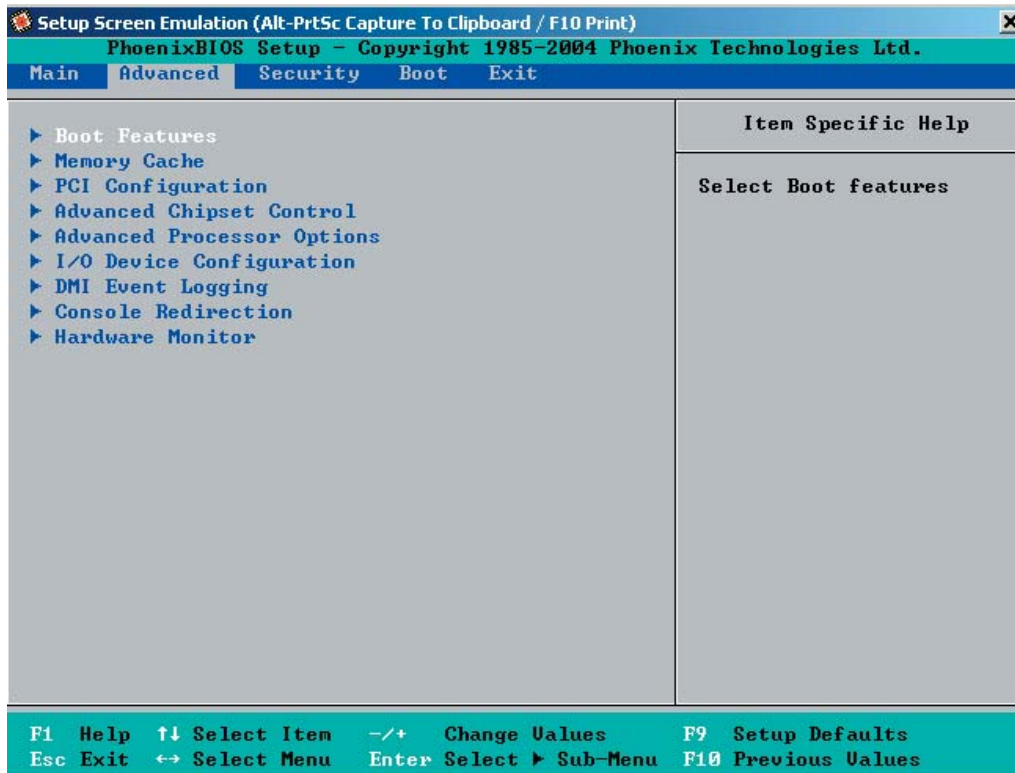

► Boot Features

Access the submenu to make changes to the following settings.

Quick Boot Mode

If enabled, this feature will speed up the POST (Power On Self Test) routine by skipping certain tests after the computer is turned on. The settings are **Enabled** and Disabled. If Disabled, the POST routine will run at normal speed.

Quiet Boot

This setting allows you to Enable or **Disable** the diagnostic screen during boot-up.

ACPI Mode

Use the setting to determine if you want to employ ACPI (Advanced Configuration and Power Interface) power management on your system. The options are **Yes** and No.

Power Button Behavior

If set to Instant-Off, the system will power off immediately as soon as the user hits the power button. If set to 4-sec., the system will power off when the user presses the power button for 4 seconds or longer. The options are **instant-off** and 4-sec override.

After Power Failure

This setting allows you to choose how the system will react when power returns after an unexpected loss of power. The options are **Stay Off** and Power On.

Watch Dog

If enabled, this option will automatically reset the system if the system is not active for more than 5 minutes. The options are Enabled and **Disabled**.

Summary Screen

This setting allows you to **Enable** or Disable the summary screen which displays the system configuration during bootup.

► Memory Cache

Cache System BIOS Area

This setting allows you to designate a reserve area in the system memory to be used as a System BIOS buffer to allow the BIOS write (cache) its data into this reserved memory area. Select **"Write Protect"** to enable this function, and this area will be reserved for BIOS ROM access only. Select "Uncached" to disable this function and make this area available for other devices.

Cache Video BIOS Area

This setting allows you to designate a reserve area in the system memory to be used as a Video BIOS buffer to allow the BIOS write (cache) its data into this reserved memory area. Select **"Write Protect"** to enable the function and this area will be reserved for Video BIOS ROM access only. Select "Uncached" to disable this function and make this area available for other devices.

Cache Base 0-512K

If enabled, this feature will allow the data stored in the base memory area: block 0-512K to be cached (written) into a buffer, a storage area in the Static DRAM (SDROM) or to be written into L1, L2 cache inside the CPU to speed up CPU operations. Select "Uncached" to disable this function. Select "Write Through"

to allow data to be cached into the buffer and written into the system memory at the same time. Select "Write Protect" to prevent data from being written into the base memory area of Block 0-512K. Select "Write Back" to allow CPU to write data back directly from the buffer without writing data to the System Memory for fast CPU data processing and operation. The options are "Uncached", "Write Through", "Write Protect", and **"Write Back"**.

Cache Base 512K-640K

If enabled, this feature will allow the data stored in the memory area: 512K-640K to be cached (written) into a buffer, a storage area in the Static DRM (SDROM) or written into L1, L2, L3 cache inside the CPU to speed up CPU operations. Select "Uncached" to disable this function. Select "Write Through" to allow data to be cached into the buffer and written into the system memory at the same time. Select "Write Protect" to prevent data from being written into the base memory area of Block 0-512K. Select "Write Back" to allow CPU to write data back directly from the buffer without writing data to the System Memory for fast CPU data processing and operation. The options are "Uncached", "Write Through", "Write Protect", and **"Write Back"**.

Cache Extended Memory

If enabled, this feature will allow the data stored in the extended memory area to be cached (written) into a buffer, a storage area in the Static DRM (SDROM) or written into L1, L2, L3 cache inside the CPU to speed up CPU operations. Select "Uncached" to disable this function. Select "Write Through" to allow data to be cached into the buffer and written into the system memory at the same time. Select "Write Protect" to prevent data from being written into the base memory area of Block 0-512K. Select "Write Back" to allow CPU to write data back directly from the buffer without writing data to the System Memory for fast CPU data processing and operation. The options are "Uncached", "Write Through", "Write Protect", and **"Write Back"**.

Discrete MTRR Allocation

If enabled, MTRRs (-Memory Type Range Registers) are configured as distinct, separate units and cannot be overlapped. If enabled, the user can achieve better graphic effects when using a Linux graphic driver that requires the write-combining configuration with 4GB or more memory. The options are Enabled and **Disabled**.

► PCI Configuration

Access the submenu to make changes to the following settings for PCI devices.

Onboard GLAN (Gigabit- LAN) OPROM Configure

Enabling this option provides the capability to boot from GLAN. The options are **Disabled** and **Enabled**.

Onboard SCSI OPROM Configure

Enabling this option provides the capability to boot from SCSI. The options are **Disabled** and **Enabled**.

Default Primary Video Adapter

This option allows the user to decide which video adapt is the default primary video adapter for the system. The options are **Onboard** and **Other**.

PCI Parity Error Forwarding

If set to **Enabled**, NMI signals will be generated when a PCI Parity Error occurs. The options are **Enabled** and **Disabled**.

ROM Scan Order

If set to **Onboard First**, the Onboard PCI Option ROM will be activated first before the Add-On Device Option ROM is activated. The options are **Add-On First** and **Onboard First**.

Reset Configuration Data

If set to **Yes**, this setting clears the Extended System Configuration Data- (ESCD) area. The options are **Yes** and **No**.

Frequency for PCIX#1/GLAN, PCIX#2/MASS, PCIX#1/MASS, PCIX#2/GLAN

This option allows the user to change the bus frequency for the devices installed in the slot indicated. The options are **Auto**, **PCI 33 MHz**, **PCI 66 MHz**, **PCI-X 66 MHz**, **PCI-X 100 MHz**, and **PCI-X 133 MHz**.

► PCI-X 100MHz Slot#1 w/ZCR, PCI-X 100 MHz Slot#2, PCI-Express x8 Slot#1, PCI-Express x8 Slot#2

Access the submenu for each of the settings above to make changes to the following:

Option ROM Scan

When enabled, this setting will initialize the device expansion ROM. The options are **Enabled** and **Disabled**.

Enable Master

This setting allows you to enable the selected device as the PCI bus master. The options are **Enabled** and **Disabled**.

Latency Timer

This setting allows you to set the clock rate for Bus Master. A high-priority, high-throughput device may benefit from a greater Clock rate. The options are **Default**, 0020h, 0040h, 0060h, 0080h, 00A0h, 00C0h, and 00E0h. For Unix, Novell and other Operating Systems, please select the option: other. If a drive fails after the installation of a new software, you might want to change this setting and try again. Different OS requires different Bus Master clock rate.

Large Disk Access Mode

This setting determines how large hard drives are to be accessed. The options are **DOS** or Other (for Unix, Novelle NetWare and other operating systems).

► Advanced Chipset Control

Access the submenu to make changes to the following settings.

Force Compliance Mode

This feature allows you to enable the PCI-Express Compliance Mode. The options are: **Disabled** or Enabled.

Memory RAS Feature Control

Select this option in order to enable the special feature of DIMM sparing or memory mirroring. The options are Mirroring, Sparing and **Standard**.

Clock Spectrum Feature

If "Enabled", BIOS will monitor the level of Electromagnetic Interference caused by the components and will attempt to decrease the interference whenever needed. The options are Enabled and **Disabled**.

Memory Remap Function Control

Set to Enabled to re-allocate memory resources for PCI slots. The options are **Enabled** and Disabled.

DRAM Data Integrity Mode

If enabled, this feature allows the data stored in the DRMA memory to be integrated for faster data processing. The options are 72-bit ECC, 144-bit ECC, **Auto** and Disabled.

ECC Error Type

This setting lets you select which type of interrupt to be activated as a result of an ECC error. The options are None, NMI (Non-Maskable Interrupt), **SMI** (System Management Interrupt) and SCI (System Control Interrupt.)

SERR Signal Condition

This setting specifies the ECC Error conditions that an SERR# is to be asserted. The options are None, **Single Bit**, Multiple Bit and Both.

Enabling Multi-Media Timer

Select Yes to enable Multi-Media Timer. The options are Yes and **No**.

USB Function

This setting allows you to **Enable** or Disable all functions for the Onboard USB devices. The options are **Enabled** and Disabled.

Legacy USB Support

This setting allows you to enable support for Legacy USB devices. The settings are **Enabled** and Disabled.

►Advanced Processor Options

Access the submenu to make changes to the following settings.

CPU Speed

This is a display that indicates the speed of the installed processor.

Hyper-threading

This setting allows you to **Enable** or Disable the function of hyper-threading. Enabling hyper-threading results in increased CPU performance. (Applicable for the XP systems.)

Machine Checking

Enable to allow the operating system to debug a system crash after a reset. The options are **Disabled** and Enabled.

C1 Enhanced Mode (*Available when supported by the CPU.)

Set to Enabled to enable the Enhanced Halt State. The options are Enabled and **Disabled**. (***Note:** please refer to Intel's web site for detailed information.)

No Execute Mode Memory Protection (*Available when supported by the CPU.)

Enable this feature to enable the functionality of Execute Disable Bit and allow the processor to classify areas in the memory where an application code can execute and where it cannot, and thus preventing a worm or a virus from inserting and creating a flood of codes that will overwhelm the processor or damage the system during an attack. (*Note: this feature is available when your OS and your CPU support the function of Execute Disable Bit.) The options are Disabled and **Enabled**. (*Note: For more information regarding hardware/software support for this function, please refer to Intel's and Microsoft's web sites.)

Thermal Management 2 (*Available when supported by the CPU.)

If enabled, this feature allows you to select between Thermal Manager 1 and Thermal Manager 2. Set to **Disable** to activate the function of TM1, allowing the CPU to regulate its power consumption based upon the modulation of the CPU Internal clock when the CPU temperature reaches a pre-defined overheat threshold. Set to Enable to activate the function of TM2, which will allow the CPU to reduce its power consumption by lowering the CPU frequency and the CPU voltage when the CPU temperature reaches a pre-defined overheat threshold. (*Note: please refer to Intel's web site for detailed information.)

Adjacent Cache Line Prefetch

The CPU fetches the cache line for 64 bytes if Disabled. The CPU fetches both cache lines for 128 bytes as comprised if **Enabled**.

► **I/O Device Configuration**

Access the submenu to make changes to the following settings.

KBC Clock input

This setting allows you to set the clock frequency for the Keyboard Clock. The options are 8MHz, **12 MHz** and 16MHz.

Onboard COM1

This setting allows you to assign control of Onboard COM1. The options are **Enabled** (user defined), Disabled, and Auto (BIOS- or OS- controlled).

Base I/O Address

Select the base I/O address for COM1. The options are **3F8/IRQ4**, 2F8/IRQ3, 3E8/IRQ4 and 2E8/IRQ3.

Onboard COM2

This setting allows you to assign control of Onboard COM2. The options are **Enabled** (user defined), Disabled, and Auto (BIOS- or OS- controlled).

Base I/O Address

Select the base I/O address for COM2. The options are 3F8/IRQ4, **2F8/IRQ3**, 3E8/IRQ4 and 2E8/IRQ3.

Floppy Disk Controller

This setting allows you to assign control of the floppy disk controller. The options are **Enabled** (user defined), Disabled, and Auto (BIOS and OS controlled).

Base I/O Address

Select the base I/O address for the parallel port. The options are **Primary** and Secondary.

► DMI Event Logging

Access the submenu to make changes to the following settings.

Event Log Validity

This is a display to inform you of the event log validity. It is not a setting.

Event Log Capacity

This is a display to inform you of the event log capacity. It is not a setting.

View DMI Event Log

Highlight this item and press <Enter> to view the contents of the event log.

Event Logging

This setting allows you to **Enable** or Disable event logging.

ECC Event Logging

This setting allows you to **Enable** or Disable ECC event logging.

Mark DMI Events as Read

Highlight this item and press <Enter> to mark the DMI events as read.

Clear All DMI Event Logs

Select Yes and press <Enter> to clear all DMI event logs. The options are Yes and **No**.

► Console Redirection

Access the submenu to make changes to the following settings.

COM Port Address

This item allows you to specify to redirect the console to Onboard COM A or Onboard COM B. This setting can also be **Disabled**.

BAUD Rate

This item allows you to select the BAUD rate for console redirection. The options are 300, 1200, 2400, 9600, **19.2K**, 38.4K, 57.6K and 115.2K.

Console Type

This item allows you to choose from the available options to select the console type for console redirection. The options are VT100, VT100,8bit, PC-ANSI, 7bit, **PC ANSI**, VT100+, VT-UTF8.

Flow Control

This item allows you to choose from the available options to select the flow control for console redirection. The options are: None, XON/XOFF, and **CTS/RTS**.

Console Connection

This item allows you to choose select the console connection: either **Direct** or Via Modem.

Continue CR after POST

Choose whether to continue with console redirection after the POST routine. The options are On and **Off**.

► Hardware Monitor Logic

CPU Temperature Threshold

This option allows the user to set a CPU temperature threshold that will activate the alarm system when the CPU temperature reaches this pre-set temperature threshold. The options are 75°C, **80°C**, 85°C and 90°C.

Highlight this and hit <Enter> to see the data for the following items:

Temperature: These items display the Temperature status of the following items.

CPU1 Temperature

CPU2 Temperature

LM93 Temperature

LM30 Temperature

Fan Speed Control Modes [Disable, 3-pin (Server)]

This feature allows the user to decide how the system controls the speeds of onboard fans. Select "Disable" to disable of the function of fan speed control and the system will run at the full speed (12V.) Select "3-pin Server" to optimize the fan speed control via BIOS Thermal management.

Fan 1 - FAN 10: If the feature of Auto Fan Control is enabled, BIOS will automatically display the status of the fans indicated in this item.

Voltage: These items display the Voltage status of the following items.

P12V_CPU1-_Scaled

P12V_CPU2_Scaled

P12V_Scaled

CPU vio

MCH/PXH Vcore

ICH Vcore

CPU1 Vcore

CPU2 Vcore

P3V3

P5V

Vdimm

HECETA_MEM_VTT

P1V0_NIC

N12V_Scaled

P3V3_STBY

4-5 Security

Choose Security from the Phoenix BIOS Setup Utility main menu with the arrow keys. You should see the following display. Security setting options are displayed by highlighting the setting using the arrow keys and pressing <Enter>. All Security BIOS settings are described in this section.

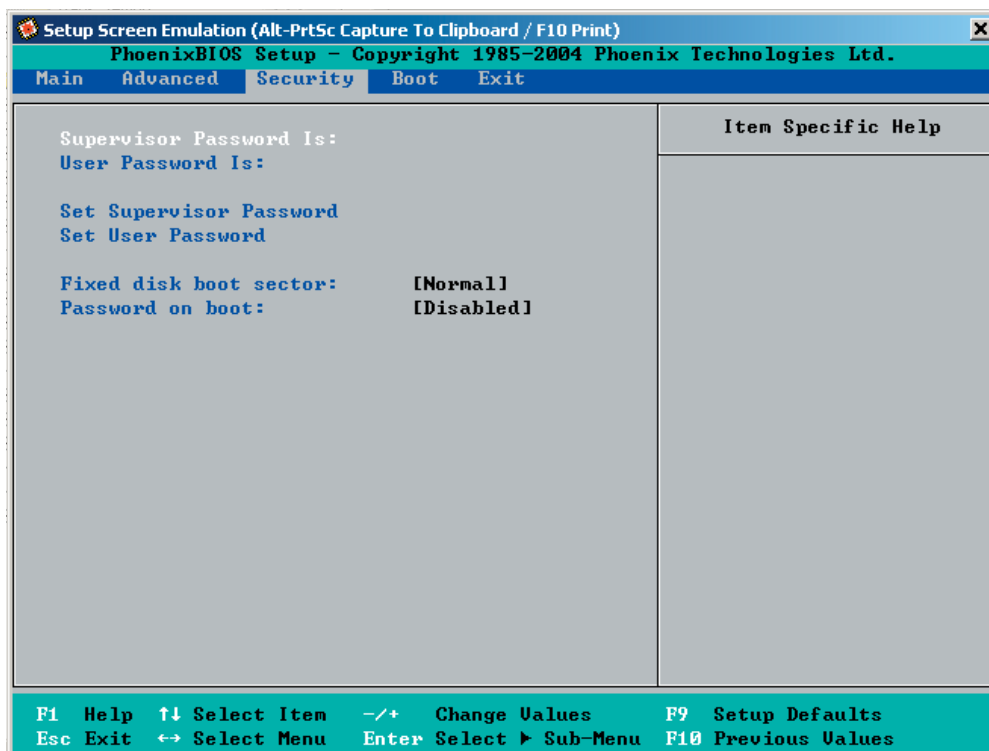

Supervisor Password Is:

This displays whether a supervisor password has been entered for the system. Clear means such a password has not been used and Set means a supervisor password has been entered for the system.

User Password Is:

This displays whether a user password has been entered for the system. Clear means such a password has not been used and Set means a user password has been entered for the system.

Set Supervisor Password

When the item "Set Supervisor Password" is highlighted, hit the <Enter> key. When prompted, type the Supervisor's password in the dialogue box to set or to change supervisor's password, which allows access to BIOS.

Set User Password

When the item "Set User Password" is highlighted, hit the <Enter> key. When prompted, type the user's password in the dialogue box to set or to change the user's password, which allows access to the system at boot-up.

Fixed Disk Boot Sector

This setting may offer some protection against viruses when set to Write Protect, which protects the boot sector on the hard drive from having a virus written to it. The other option is **Normal**.

Password on Boot

This setting allows you to require a password to be entered when the system boots up. The options are Enabled (password required) and Disabled (password not required).

4-6 Boot

Choose Boot from the Phoenix BIOS Setup Utility main menu with the arrow keys. You should see the following display. Highlighting a setting with a + or - will expand or collapse that entry. See details on how to change the order and specs of boot devices in the Item Specific Help window. All Boot BIOS settings are described in this section.

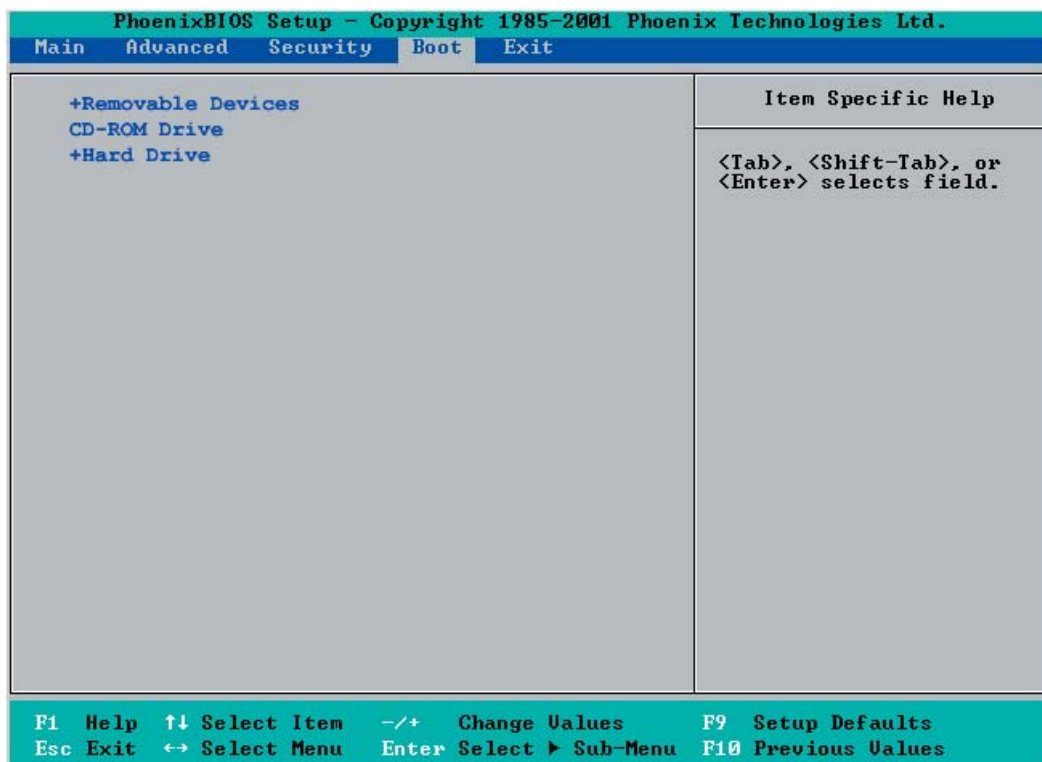

+Removable Devices

Highlight and press <Enter> to expand the field. See details on how to change the order and specs of devices in the Item Specific Help window.

CDROM Drive

See details on how to change the order and specs of the CDROM drive in the Item Specific Help window.

+Hard Drive

Highlight and press <Enter> to expand the field. See details on how to change the order and specs of hard drives in the Item Specific Help window.

4-7 Exit

Choose Exit from the Phoenix BIOS Setup Utility main menu with the arrow keys. You should see the following display. All Exit BIOS settings are described in this section.

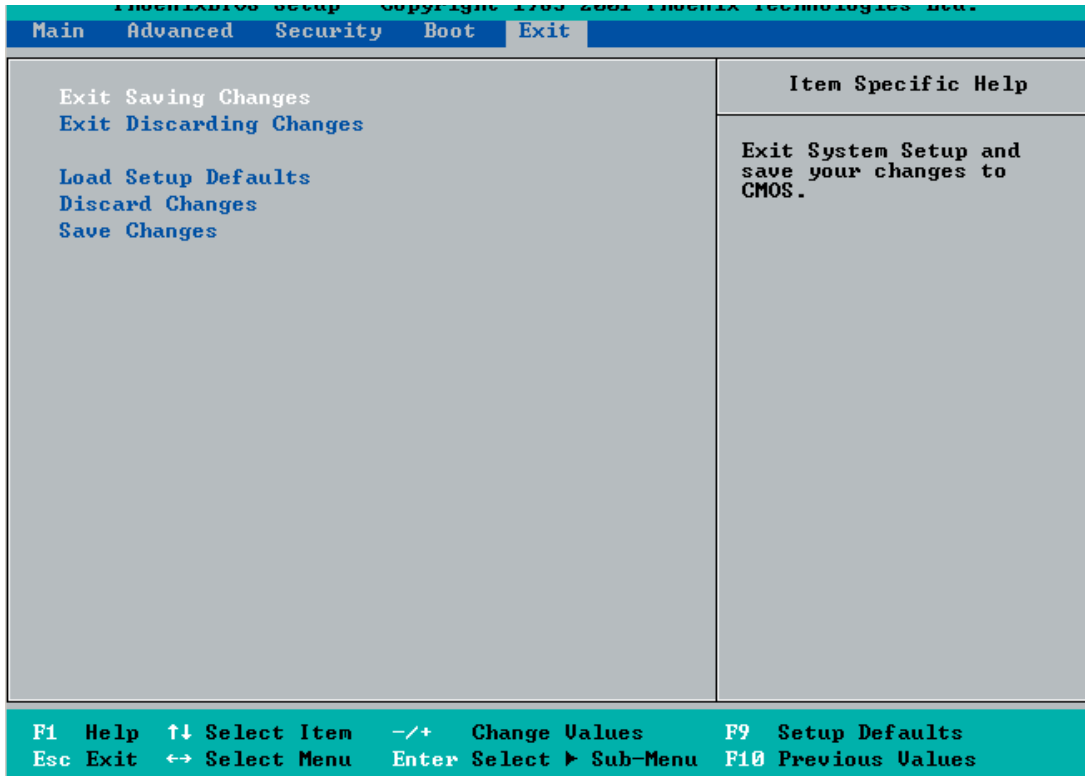

Exit Saving Changes

Highlight this item and hit <Enter> to save any changes you made and to exit the BIOS Setup utility.

Exit Discarding Changes

Highlight this item and hit <Enter> to exit the BIOS Setup utility without saving any changes you may have made.

Load Setup Defaults

Highlight this item and hit <Enter> to load the default settings for all items in the BIOS Setup. These are the safest settings to use.

Discard Changes

Highlight this item and hit <Enter> to discard (cancel) any changes you made. You will remain in the Setup utility.

Save Changes

Highlight this item and hit <Enter> to save any changes you made. You will remain in the Setup utility.

Notes

Appendix A

BIOS POST Codes

This section lists the POST (Power On Self Test) codes for the Phoenix BIOS. POST codes are divided into two categories: recoverable and terminal.

Recoverable POST Errors

When a recoverable type of error occurs during POST, the BIOS will display an POST code that describes the problem. BIOS may also issue one of the following beep codes:

1 long and two short beeps - video configuration error

1 repetitive long beep - no memory detected

Terminal POST Errors

If a terminal type of error occurs, BIOS will shut down the system. Before doing so, BIOS will write the error to port 80h, attempt to initialize video and write the error in the top left corner of the screen. The following is a list of codes that may be written to port 80h.

POST Code	Description
02h	Verify Real Mode
03h	Disable Non-Maskable Interrupt (NMI)
04h	Get CPU type
06h	Initialize system hardware
07h	Disable shadow and execute code from the ROM.
08h	Initialize chipset with initial POST values
09h	Set IN POST flag
0Ah	Initialize CPU registers
0Bh	Enable CPU cache
0Ch	Initialize caches to initial POST values
0Eh	Initialize I/O component
0Fh	Initialize the local bus IDE
10h	Initialize Power Management
11h	Load alternate registers with initial POST values
12h	Restore CPU control word during warm boot
13h	Initialize PCI Bus Mastering devices
14h	Initialize keyboard controller
16h	1-2-2-3 BIOS ROM checksum
17h	Initialize cache before memory Auto size

POST Code	Description
18h	8254 timer initialization
1Ah	8237 DMA controller initialization
1Ch	Reset Programmable Interrupt Controller
20h	1-3-1-1 Test DRAM refresh
22h	1-3-1-3 Test 8742 Keyboard Controller
24h	Set ES segment register to 4 GB
28h	Auto size DRAM
29h	Initialize POST Memory Manager
2Ah	Clear 512 kB base RAM
2Ch	1-3-4-1 RAM failure on address line xxxx*
2Eh	1-3-4-3 RAM failure on data bits xxxx* of low byte of memory bus
2Fh	Enable cache before system BIOS shadow
32h	Test CPU bus-clock frequency
33h	Initialize Phoenix Dispatch Manager
36h	Warm start shut down
38h	Shadow system BIOS ROM
3Ah	Auto size cache
3Ch	Advanced configuration of chipset registers
3Dh	Load alternate registers with CMOS values
41h	Initialize extended memory for RomPilot
42h	Initialize interrupt vectors
45h	POST device initialization
46h	2-1-2-3 Check ROM copyright notice
47h	Initialize I20 support
48h	Check video configuration against CMOS
49h	Initialize PCI bus and devices
4Ah	Initialize all video adapters in system
4Bh	QuietBoot start (optional)
4Ch	Shadow video BIOS ROM
4Eh	Display BIOS copyright notice
4Fh	Initialize MultiBoot
50h	Display CPU type and speed
51h	Initialize EISA board
52h	Test keyboard
54h	Set key click if enabled
55h	Enable USB devices
58h	2-2-3-1 Test for unexpected interrupts
59h	Initialize POST display service
5Ah	Display prompt "Press F2 to enter SETUP"
5Bh	Disable CPU cache

POST Code	Description
5Ch	Test RAM between 512 and 640 kB
60h	Test extended memory
62h	Test extended memory address lines
64h	Jump to UserPatch1
66h	Configure advanced cache registers
67h	Initialize Multi Processor APIC
68h	Enable external and CPU caches
69h	Setup System Management Mode (SMM) area
6Ah	Display external L2 cache size
6Bh	Load custom defaults (optional)
6Ch	Display shadow-area message
6Eh	Display possible high address for UMB recovery
70h	Display error messages
72h	Check for configuration errors
76h	Check for keyboard errors
7Ch	Set up hardware interrupt vectors
7Dh	Initialize Intelligent System Monitoring
7Eh	Initialize coprocessor if present
80h	Disable onboard Super I/O ports and IRQs
81h	Late POST device initialization
82h	Detect and install external RS232 ports
83h	Configure non-MCD IDE controllers
84h	Detect and install external parallel ports
85h	Initialize PC-compatible PnP ISA devices
86h	Re-initialize onboard I/O ports.
87h	Configure Motherboard Configurable Devices (optional)
88h	Initialize BIOS Data Area
89h	Enable Non-Maskable Interrupts (NMIs)
8Ah	Initialize Extended BIOS Data Area
8Bh	Test and initialize PS/2 mouse
8Ch	Initialize floppy controller
8Fh	Determine number of ATA drives (optional)
90h	Initialize hard-disk controllers
91h	Initialize local-bus hard-disk controllers
92h	Jump to UserPatch2
93h	Build MPTABLE for multi-processor boards
95h	Install CD ROM for boot
96h	Clear huge ES segment register
97h	Fix up Multi Processor table
98h	1-2 Search for option ROMs. One long, two short beeps on checksum failure

POST Code	Description
99h	Check for SMART Drive (optional)
9Ah	Shadow option ROMs
9Ch	Set up Power Management
9Dh	Initialize security engine (optional)
9Eh	Enable hardware interrupts
9Fh	Determine number of ATA and SCSI drives
A0h	Set time of day
A2h	Check key lock
A4h	Initialize typematic rate
A8h	Erase F2 prompt
AAh	Scan for F2 key stroke
ACh	Enter SETUP
AEh	Clear Boot flag
B0h	Check for errors
B1h	Inform RomPilot about the end of POST.
B2h	POST done - prepare to boot operating system
B4h	1 One short beep before boot
B5h	Terminate QuietBoot (optional)
B6h	Check password (optional)
B7h	Initialize ACPI BIOS
B9h	Prepare Boot
BAh	Initialize SMBIOS
BBh	Initialize PnP Option ROMs
BCh	Clear parity checkers
BDh	Display MultiBoot menu
BEh	Clear screen (optional)
BFh	Check virus and backup reminders
C0h	Try to boot with INT 19
C1h	Initialize POST Error Manager (PEM)
C2h	Initialize error logging
C3h	Initialize error display function
C4h	Initialize system error handler
C5h	PnPnd dual CMOS (optional)
C6h	Initialize note dock (optional)
C7h	Initialize note dock late
C8h	Force check (optional)
C9h	Extended checksum (optional)
CAh	Redirect Int 15h to enable remote keyboard
CBh	Redirect Int 13h to Memory Technologies Devices such as ROM, RAM, PCMCIA, and serial disk
CCh	Redirect Int 10h to enable remote serial video

POST Code	Description
CDh	Re-map I/O and memory for PCMCIA
CEh	Initialize digitizer and display message
D2h	Unknown interrupt

The following are for boot block in Flash ROM

POST Code	Description
E0h	Initialize the chipset
E1h	Initialize the bridge
E2h	Initialize the CPU
E3h	Initialize system timer
E4h	Initialize system I/O
E5h	Check force recovery boot
E6h	Checksum BIOS ROM
E7h	Go to BIOS
E8h	Set Huge Segment
E9h	Initialize Multi Processor
EAh	Initialize OEM special code
EBh	Initialize PIC and DMA
ECh	Initialize Memory type
EDh	Initialize Memory size
EEh	Shadow Boot Block
EFh	System memory test
F0h	Initialize interrupt vectors
F1h	Initialize Run Time Clock
F2h	Initialize video
F3h	Initialize System Management Manager
F4h	Output one beep
F5h	Clear Huge Segment
F6h	Boot to Mini DOS
F7h	Boot to Full DOS

* If the BIOS detects error 2C, 2E, or 30 (base 512K RAM error), it displays an additional word-bitmap (xxxx) indicating the address line or bits that failed. For example, "2C 0002" means address line 1 (bit one set) has failed. "2E 1020" means data bits 12 and 5 (bits 12 and 5 set) have failed in the lower 16 bits. The BIOS also sends the bitmap to the port-80 LED display. It first displays the checkpoint code, followed by a delay, the high-order byte, another delay, and then the loworder byte of the error. It repeats this sequence continuously.

Notes

Appendix B

Installing Software Drivers and the Windows Operating System

B-1 The Adaptec Embedded SAS/SATA with HostRAID Controller Driver

Introduction to SATA (Serial ATA) and SAS (Serial Attached SCSI)

Serial ATA(SATA) is a physical storage interface. It uses a single cable with a minimum of four wires to create a point-to-point connection between devices. It is a serial link which supports SATA transfer rates from 150MBps. Because the serial cables used in SATA are thinner than the traditional cables used in Parallel ATA (PATA), SATA systems provide more efficient system cooling, faster data transfer and better functionality than Parallel ATA.

With the functionality provided by the onboard SAS controller, the Supermicro X6DHP-3G2 offers unprecedented I/O throughput, reliability and scalability to the IT industry. In addition, with a dynamic SAS infrastructure built-in, the X6DHP-3G2 supports both SATA and SAS without any bridging, providing the user with unparalleled data storage expansion and inter-connectivity capability. (***Note:** The onboard SAS Controller supports both SATA and SAS RAID configuration; however, "mixing-and-matching" SATA and SAS in the configuration is not recommended.)

Using the Adaptec RAID Configuration Utility (ARC)

(*Note: Please also refer to the following sections for SATA RAID Configuration.)

The onboard SAS Controller is enabled by default. To disable it, please set Jumper JPS1 to Pins 2-3. (See Page 2-21 in Chapter 2 for details.)

* Upon detecting the SAS Controller BIOS, please make sure that the Adapter WWN address is listed. This is a 16-digit number. If this number is not shown, you will not be able to use the controller.

* Once the WWN address is listed, press the <Ctrl> and <A> simultaneously when prompted to access the Adaptec SAS RAID BIOS. (***Note:** To select an option, use the arrow keys to highlight the item and then press <Enter> to select it. To return to the previous menu, press <ESC>.)

The Adaptec RAID Configuration Utility is an embedded BIOS Utility, including:

* Array Configuration Utility: Use this utility to create, configure and manage arrays.

* SerialSelect Utility: Use this option to configure SAS/SATA RAID drives.

* Disk Utilities: Use this option to format or verify disks.

A. Using the Array Configuration Utility

The Array Configuration Utility enables you to create, manage, and delete arrays from the controller's BIOS, add and delete spare drives, and initialize drives. During the system startup, press <Ctrl> and <A> simultaneously to display the main menu.

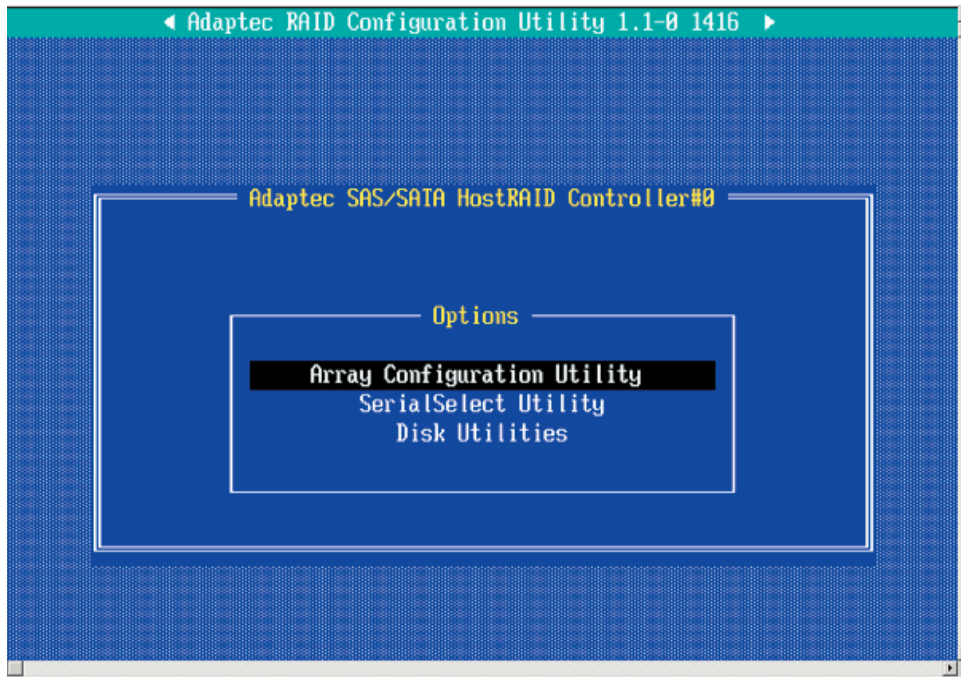

Managing Arrays

Select this option to view array properties, and delete arrays. The following sections describe the operations Of "Managing Arrays".

To select this option, use the arrow keys and the <enter> key to select "Managing Arrays" from the main menu (as shown above).

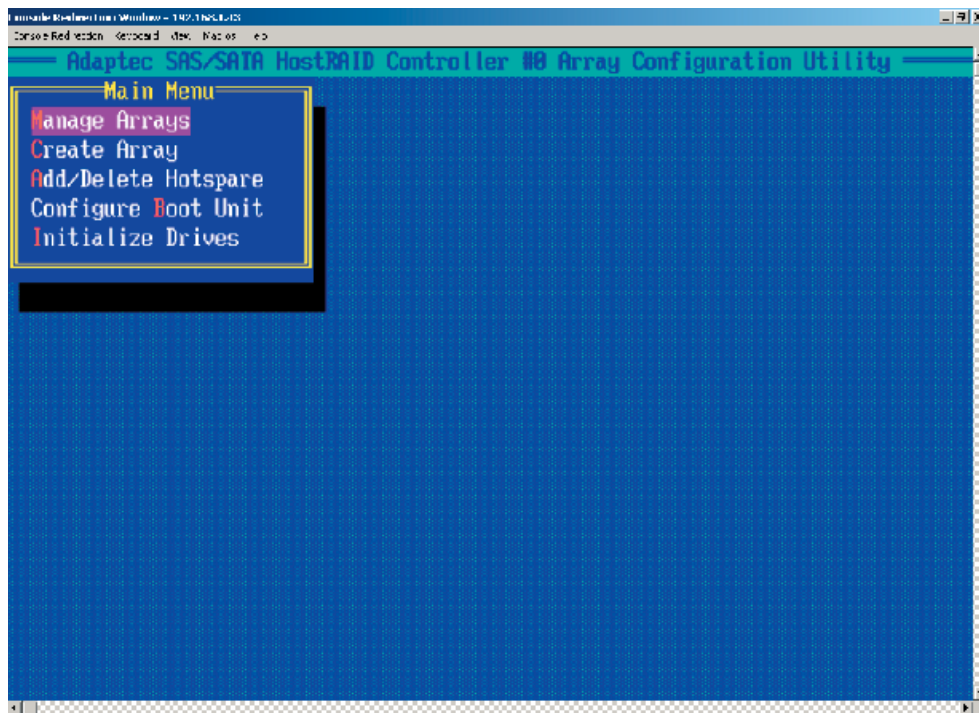

Viewing Array Properties

To view the properties of an existing array:

1. At the BIOS prompt, press **Ctrl+A**.
2. From the Adaptec RAID Configuration Utility menu, select **Array Configuration Utility**.
3. From the Array Configuration Utility menu, select **Manage Arrays** (as shown on the previous screen.)
4. From the List of Arrays dialog box, select the array you want to view and press **Enter**.

The Array Properties dialog box appears, showing detailed information on the array. The physical disks associated with the array are displayed here.

5. Press **Esc** to return to the previous menu.

Deleting Arrays

**Warning: Back up the data on an array before you delete it to prevent the loss of data. Deleted arrays cannot be restored.*

To delete an existing array:

1. Turn on your computer and press **Ctrl+A** when prompted to access the Adaptec RAID Configuration Utility.
2. From the Adaptec RAID Configuration Utility main menu, select **Array Configuration Utility**.
3. From the Array Configuration Utility menu, select **Manage Arrays**.
4. Select the array you wish to delete and press **Delete**.
5. In the Array Properties dialog box, select **Delete** and press **Enter**. The following prompt is displayed:

**Warning!! Deleting the array will render array unusable. Do you want to delete the array?(Yes/No):*

RAID 1 only—the following prompt is also displayed:

Deleting the partition will result in data loss! Do you also want to delete the partition? (Yes/No):

6. Press **Yes** to delete the array or partition or **No** to return to the previous menu.
7. Press **Esc** to return to the previous menu.

Creating Arrays

Before creating arrays, make sure the disks for the array are connected and installed in your system. Note that disks with no usable space, or disks that are uninitialized are shown in gray and cannot be used. Refer to the section: [Initializing Disk Drives](#).

To create an array:

- 1 Turn on your computer and press **Ctrl+A** when prompted to access the Adaptec RAID Configuration Utility.
- 2 From the Adaptec RAID Configuration Utility menu, select **Array Configuration Utility Main Menu**.
- 3 From the Array Configuration Utility menu, select **Create Array**.
- 4 Select the disks for the new array and press Insert (as the screen shown below).
 (*Note: To deselect any disk, highlight the disk and press **Delete**.)

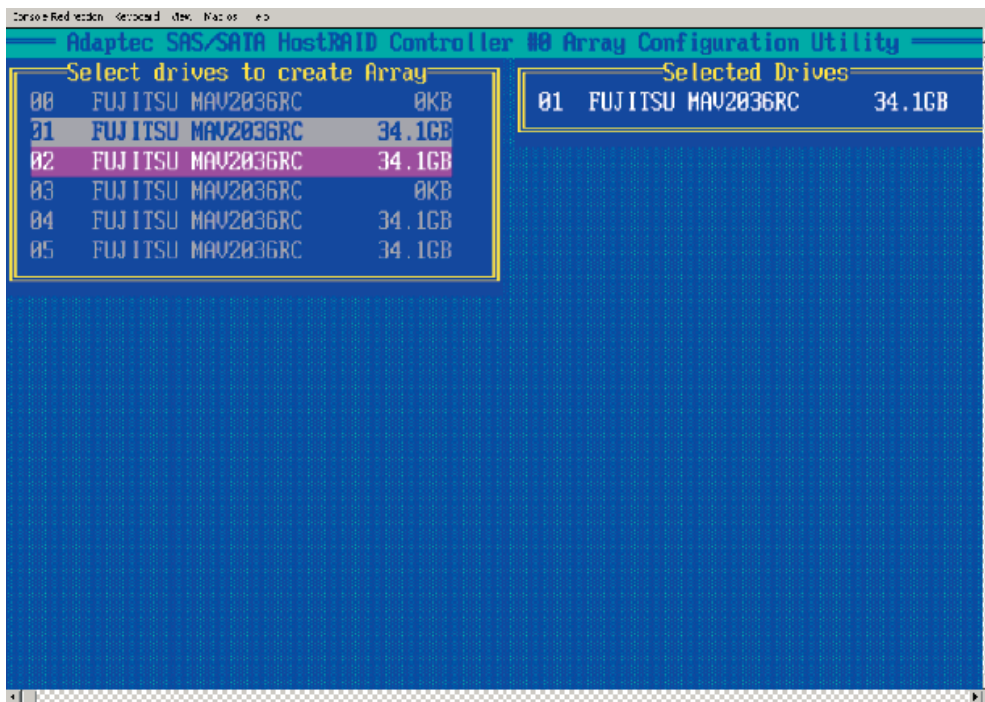

- 5 After both disks for the new array are selected, press Enter. The Array Properties menu displays (as the screen shown below).

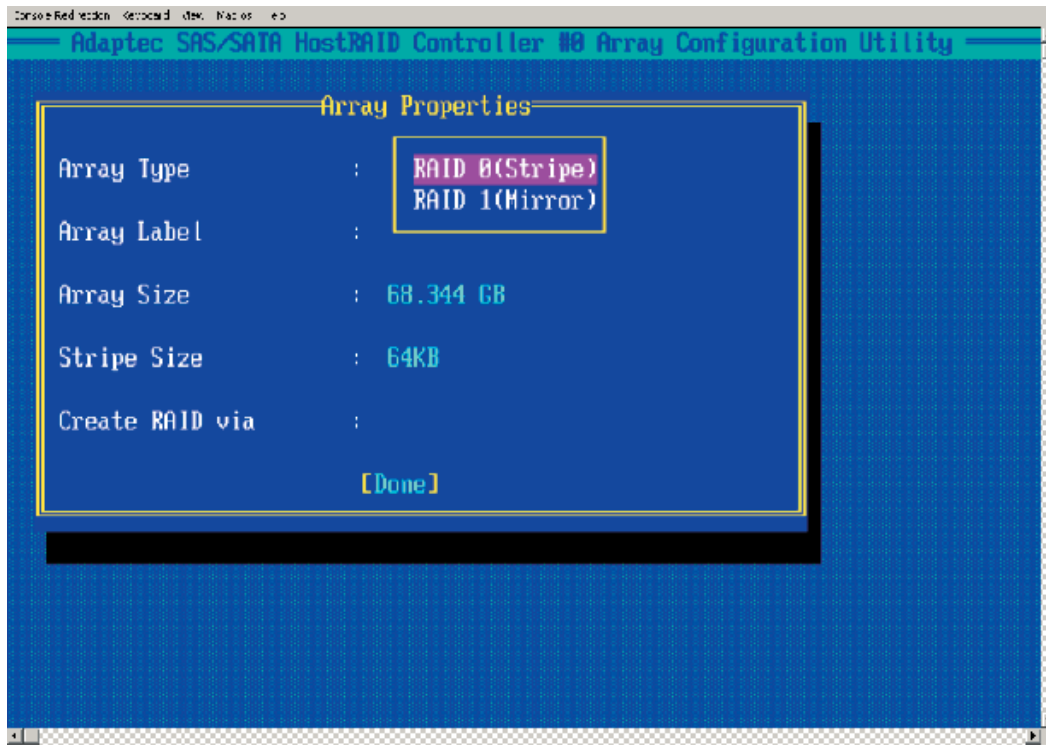

Assigning Array Properties

Once you've create a new array, you are ready to assign the properties to the array.

***Caution:** Once the array is created and its properties are assigned, you cannot change the array properties using the Array Configuration Utility. You will need to use the Adaptec Storage Manager - Browser Edition. (Refer to Adaptec's User's Guide in the enclosed CD.)

To assign properties to the new array:

1. In the Array Properties menu (as shown in the screen below), select an array type and press **Enter**.

Note that only the available array types: RAID 0, and RAID1, are displayed on the screen. (*RAID 0 or RAID 1 requires two drives.)

2. Under the item "**Arrays Label**", type in an label and press **Enter**. (***Note:** The label shall not be more than 15 characters.)

3. For RAID 0, select the desired stripe size. (***Note:** Available stripe sizes are 16, 32, and 64 KB-default. It is recommended that you *do not* change the default setting.)

4. The item: "**Create RAID via**" allows you to select between the different creating methods for RAID 0 and RAID 1.

The following table gives examples of when each is appropriate.

Raid Level	Create Via	When Appropriate
RAID 0	No Init	Creating a RAID 0 on new drives
RAID 1	Build	Any time you wish to create a RAID 1, but especially if you have data on one drive that you wish to preserve
RAID 1	Clear	Creating a RAID 1 on new drives, or when you want to ensure that the array contains no data after creation.
RAID 1	Quick	Fastest way to create a RAID 1. Appropriate when using new drives
RAID 1	Init	

(*Note: If you select Migrate for RAID 0, or Build for RAID 1, you will be asked to select the source drive. The contents of the source drive will be preserved. However, the data on the new drive will be lost.)

5. When you are finished, press **Done (as shown in the previous screen)**.

Notes:

1. Before adding a new drive to an array, back up any data contained on the new drive. Otherwise, all data will be lost.
2. If you stop the Build or Clear process on a RAID 1 from Array Configuration Utility, you can restart it by pressing Ctrl+R.
3. A RAID 1 created using the Quick Init option may return some data mis-compare if you later run a consistency check. This is normal and is not a cause for concern.
4. The Array Configuration Utility allows you to use drives of different sizes in a RAID . However, during a build operation, only the smaller drive can be selected as the source or first drive.
5. When migrating from single volume to RAID 0, migrating from a larger drive to a smaller drive is allowed. However, the destination drive must be at least half the capacity of the source drive.
6. Adaptec does not recommend that you migrate or build an array on Windows dynamic disks (volumes), as it will result in data loss.

Warning: Do not interrupt the creation of a RAID 0 using the Migrate option. If you do, you will not be able to restart, or to recover the data that was on the source drive.

Adding a Bootable Array

To make an array bootable:

1. From the Main menu, select **Configure Boot Unit** and press Enter. The following screen displays.

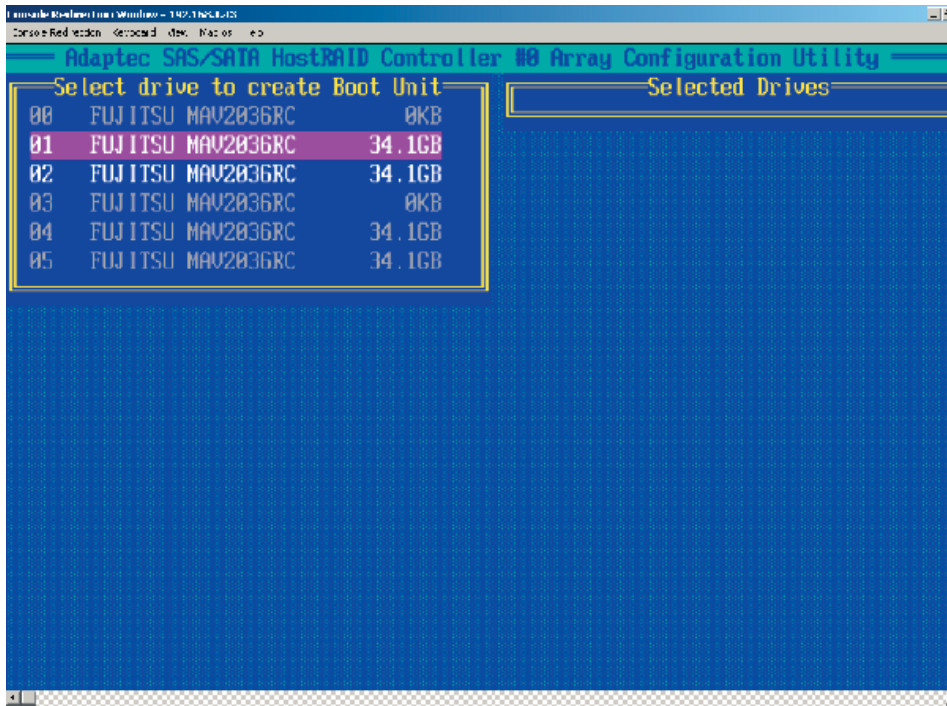

2. From the "Select Drive to Create Boot Unit" list, select the drive you wish to **Configure Boot Unit** and press Insert. The Drive you have selected appears in the right window as shown in the screen below:

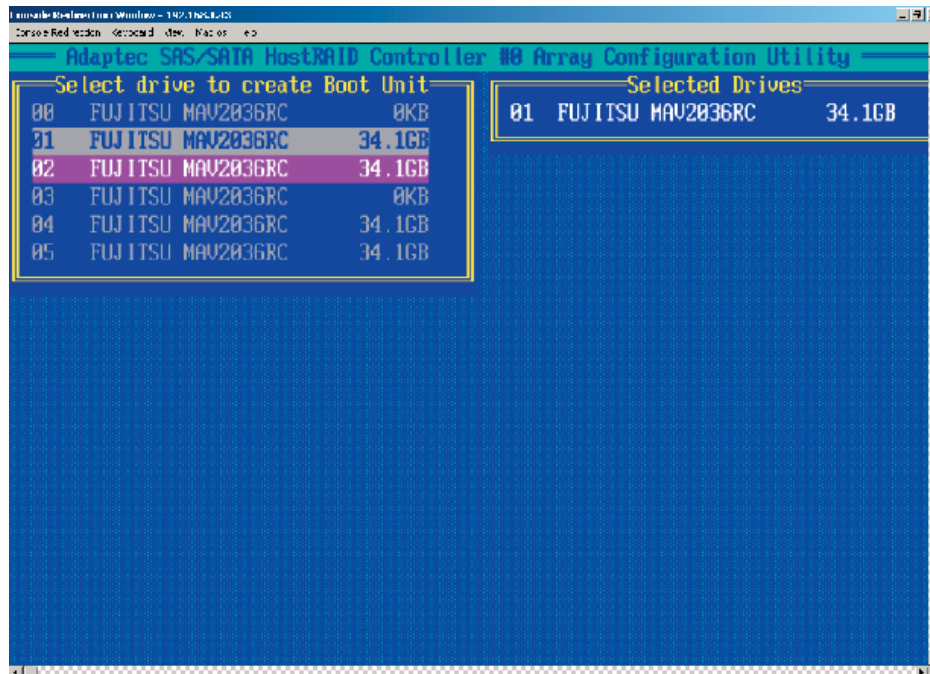

3. Select the disk drive you wish to configure as a bootable drive from the "Selected Drives" List (in the right window) and press Enter. The next screen appears.

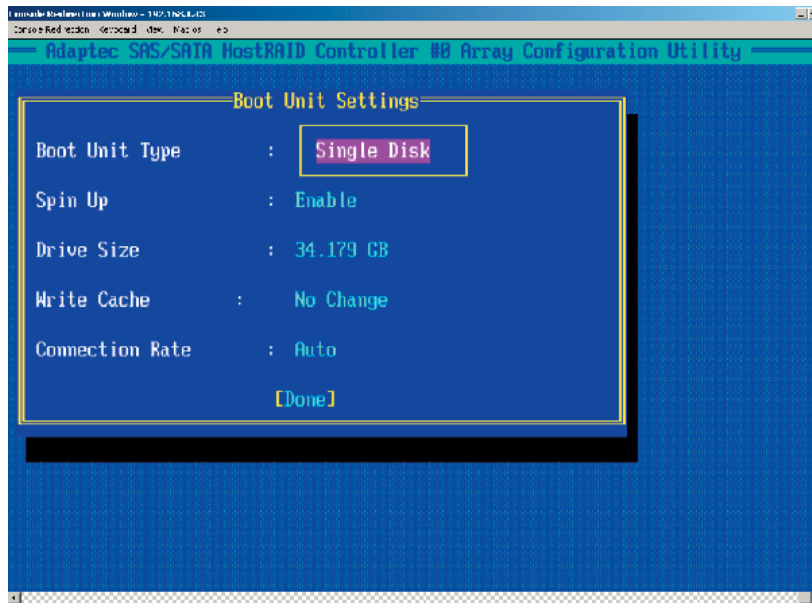

Deleting a Bootable Array

To delete a bootable array:

1. From the Main menu, select **Configure Boot Unit** and press Enter.
2. From the "Select the Boot Unit" list (in the right window), select the bootable drive you wish to delete and press Delete. The following screen appears:

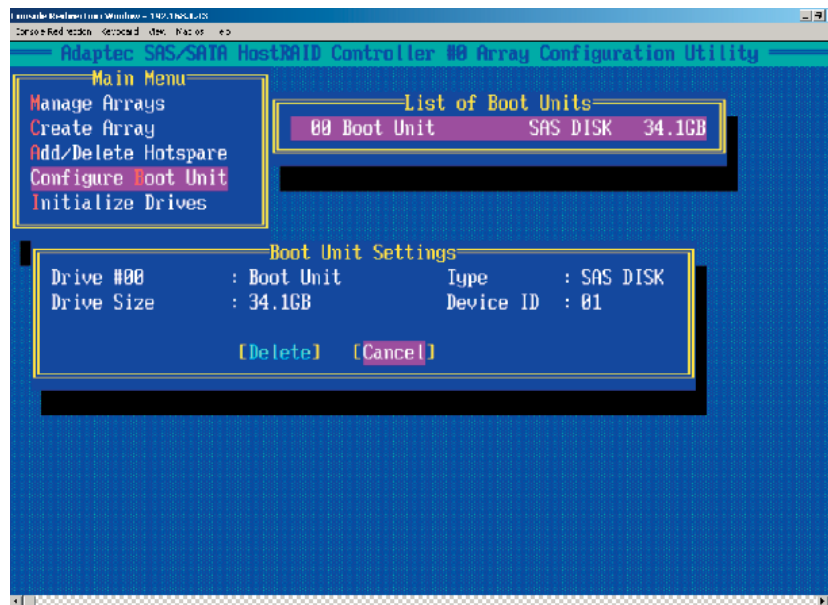

3. When the screen shown above appears, select Delete and press Enter.
4. Enter Y to delete a bootable array when the following message is displayed: "Do you want to delete the Bootable uUnit? (Yes/No):" Then, the bootable array will be deleted.

Adding/Deleting Hotspares

(*Note: In order to rebuild a RAID (RAID 0 or RAID 1), you would need to add a new HDD as a hotspare.)

1. Turn on your computer and press Ctrl+A as prompted to access the ARC Utility.
2. From the ARC menu, select Array Configuration Utility.
3. From the ACU menu, select **Add/Delete Hotspares** and press <Enter>. The following screen appears:

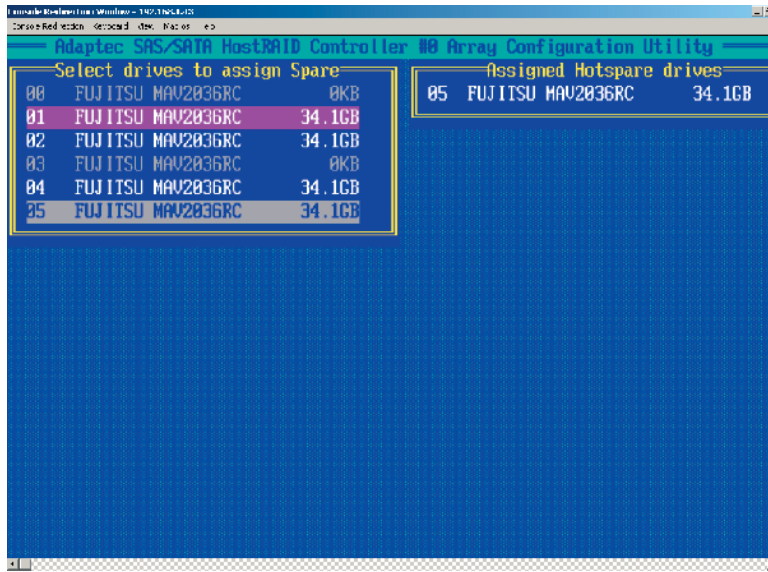

To Add a HotSpare Drive

4. Use the up and down arrow keys to highlight and select the disk you want to designate as a Hotspare, and press <Insert>, and then, press <Enter>.
5. Press yes when the following prompt is displayed: "Do you want to create spare?" (Yes/No?)

The spare you have selected will appear in the Select Drive Menu.

To Delete a HotSpare Drive

4. From the List of "Assigned HotSpare Drives" (in the right window), select the hotspare drive you want to delete, and press <Delete> and <Enter>.
5. Press yes when the following prompt is displayed: "Do you want to Delete the Hotspare?" (Yes/No?)

The hotspare drive you have selected will be deleted.

Initializing Disk Drives

If an installed disk does not appear in the disk selection list for creating a new array, or if it appears grayed out, you may have to initialize it before you can use it as part of an array. Drives attached to the controller must be initialized before they can be used in an array.

Caution: Initializing a disk overwrites the partition table on the disk and makes any data on the disk inaccessible. If the drive is used in an array, you may not be able to use the array again.

Do not initialize a disk that is part of a boot array. To determine which disks are associated with a particular array, Please refer to [Viewing Array Properties](#).

To initialize drives:

1. Turn on your computer and press **Ctrl+A** when prompted to access the Adaptec RAID Configuration utility.
2. From the Adaptec RAID Configuration Utility menu, select **Array Configuration Utility** (as shown in the screen below).

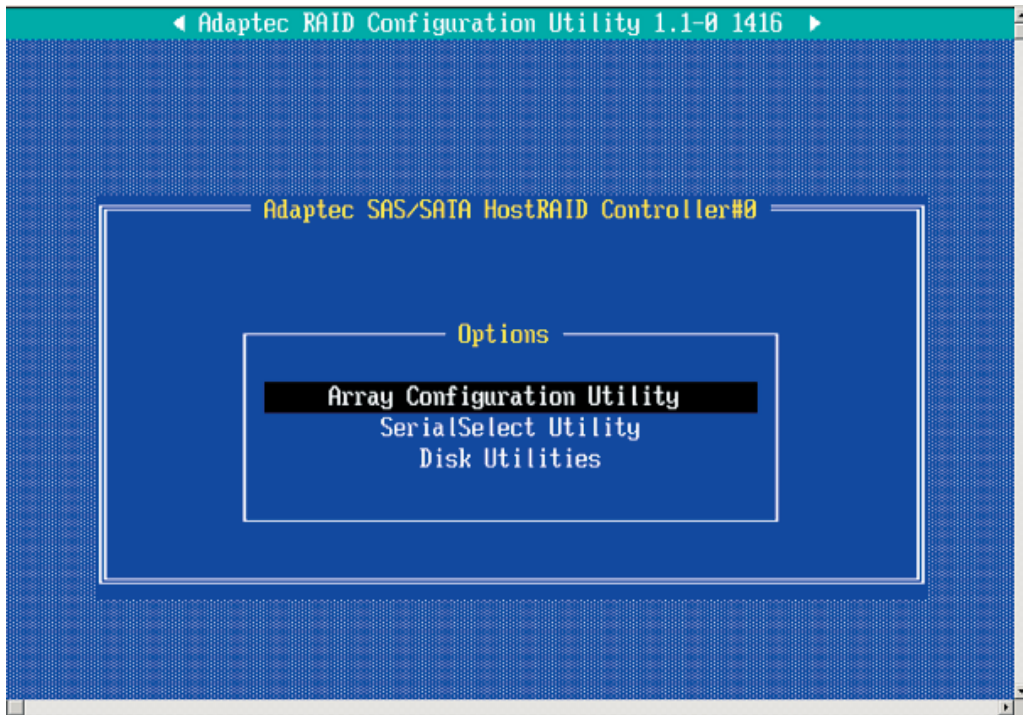

3. From the screen below, select **Initialize Drives** and press <Enter>.

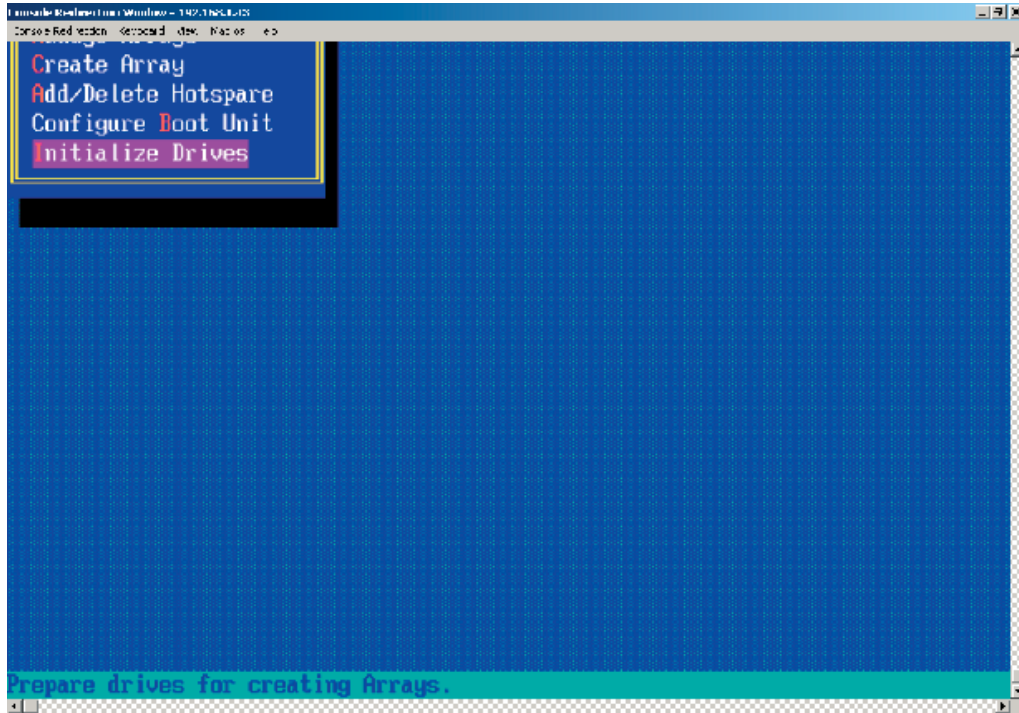

4. From the "Select drives for initialization" list (on the left screen), select the disk you wish to initialize and press Insert. The drive you've selected will appear on the "Selected Drives" list as show below:

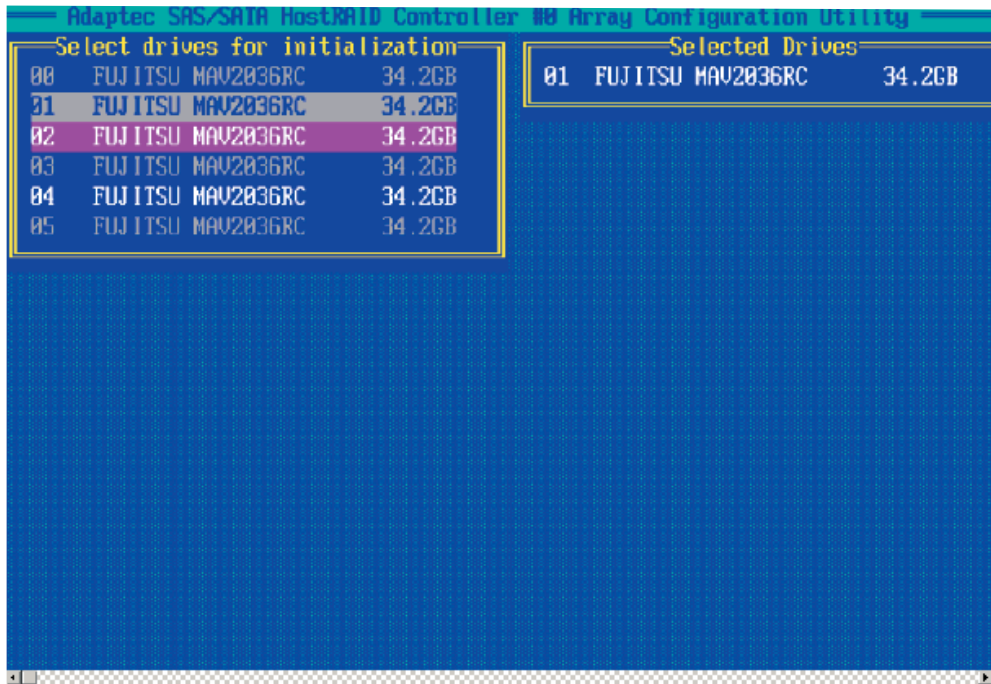

5. Repeat [Step 4](#) so that both drives to be initialized are selected and press <Enter>.

6. When the following message appears, make sure that you have selected the correct drive for initialization and press <Y> to initialize the drive or press <N> to quit.

Warning: Initialization will configure the drive(s) as simple volume disk(s). Do you want to continue? (Yes/No):

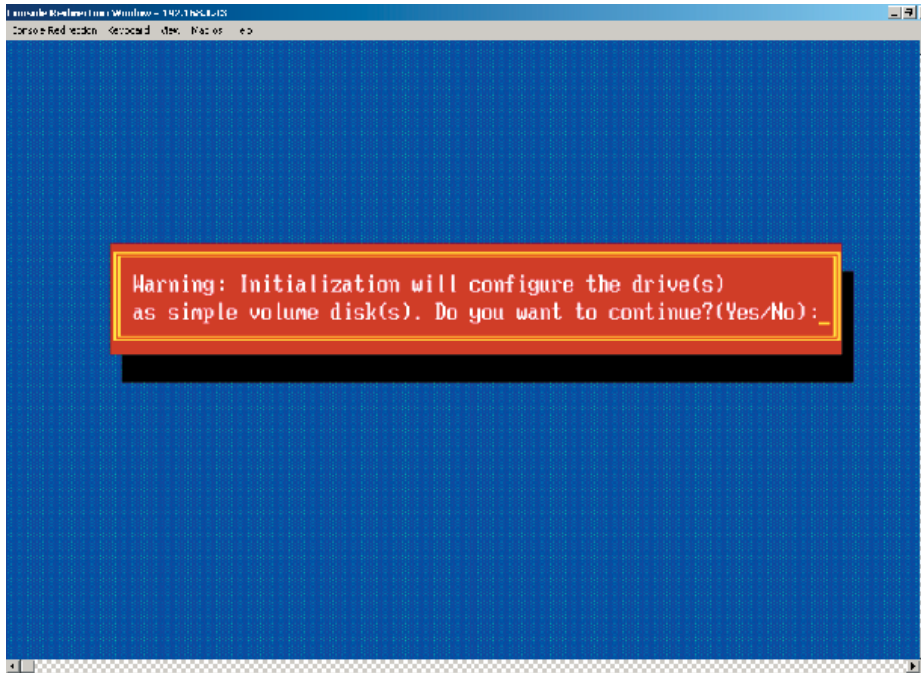

Rebuilding Arrays

***Note 1:** Rebuilding applies to Fault Tolerant array (RAID 1) only.

If an array Build process (or initialization) is interrupted or critical with one member missing, you must perform a Rebuild to get the array to Optimal status. For a critical array Rebuild operation, the optimal drive is the source drive.

***Note 2:** If no spare array exists and a hard disk drive fails, you need to create a spare before you can rebuild an array.

To Rebuild an array:

1 From the Main Menu, select **Manage Arrays** (as shown in the screen below). From the List of Arrays, select the array you want to Rebuild.

2 Press **Ctrl+R** to Rebuild.

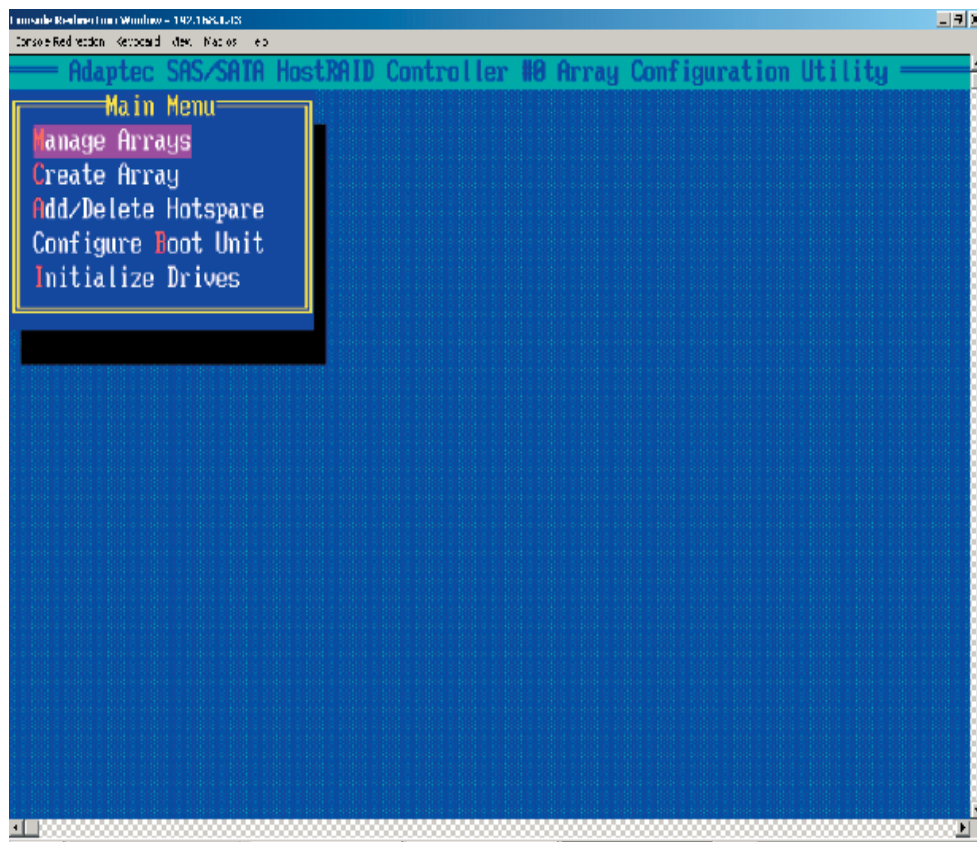

Using the SerialSelect Utility to Configure SAS Settings

The SerialSelect Utility enables you to configure SAS disk drive settings.

To access the SAS utilities:

1. Turn on your computer and press Ctrl+A when prompted to access the Adaptec RAID Configuration Utility. (as shown in the screen below.)

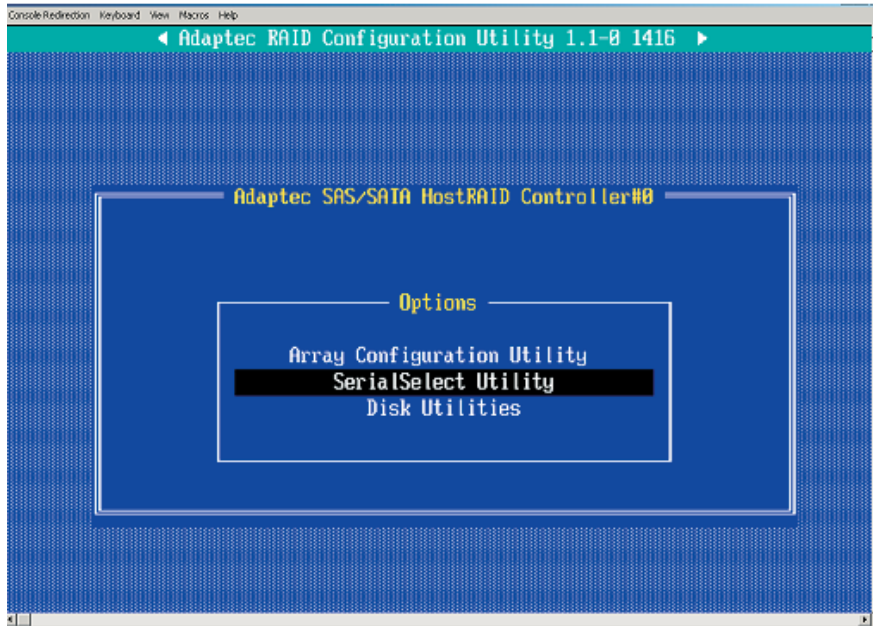

2. Use the arrow keys to select "SerialSelect Utility" and press <Enter> to access the Controller Configuration submenu:

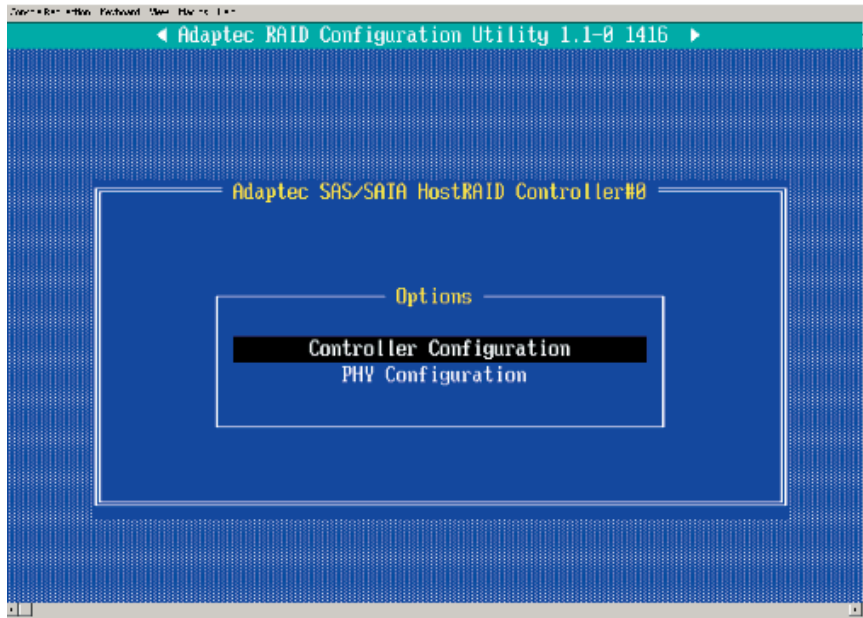

To Set Controller Configuration:

3. Select "Controller Configuration" and press <Enter> to access the submenu as shown below:

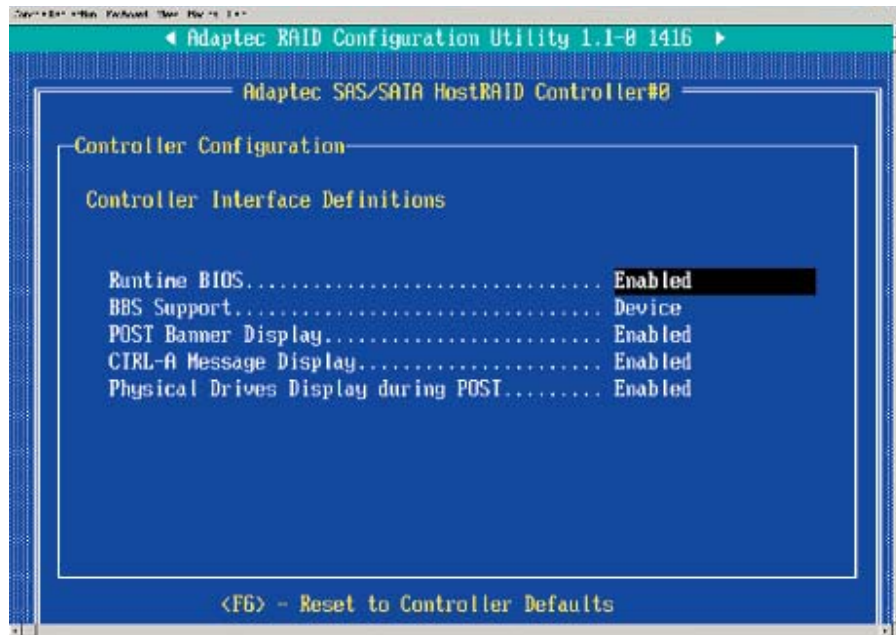

4. Use the arrow keys to select an item. Then, press <Enter> and the arrow keys to configure the setting for the item selected.

5. To load the default settings, press <F6>.

(*Note: The default setting for each item is listed below:

Runtime BIOS: Enabled,

BBS Support: Device,

POST Banner Display: Enabled,

CTRL-A Message Display: Enabled,

Physical Drives Display during POST: Enabled,)

6. Press <Esc> to return to the previous menu and to exit the utility.

To Set Physical Configuration:

1. Turn on your computer and press **Ctrl+A** when prompted to access the Adaptec RAID Configuration Utility.
2. Use the arrow keys to select "SerialSelect Utility" and press <Enter> to access the Physical Configuration submenu as shown below:

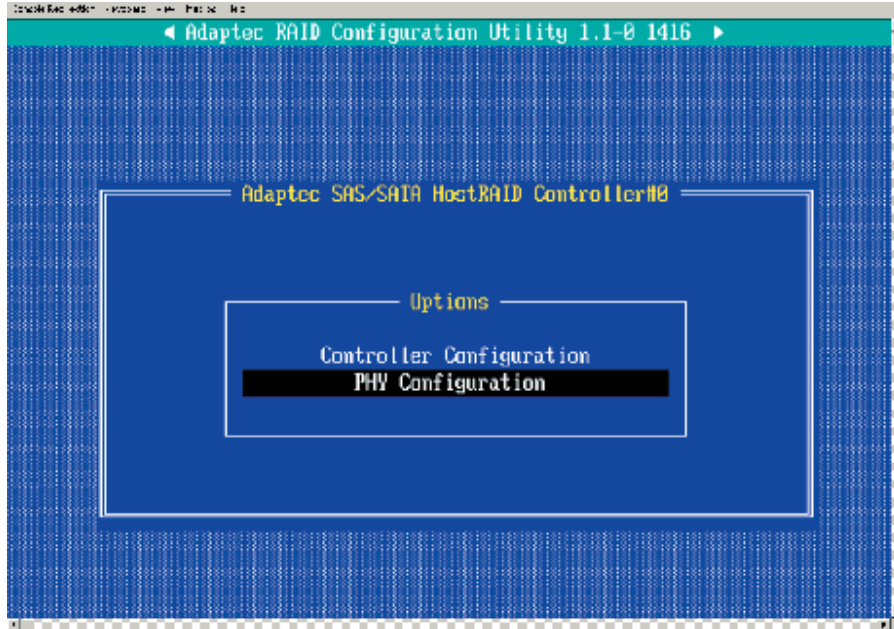

3. Select "Physical Configuration" and press <Enter> to access SAS Device Configuration submenu as shown below:

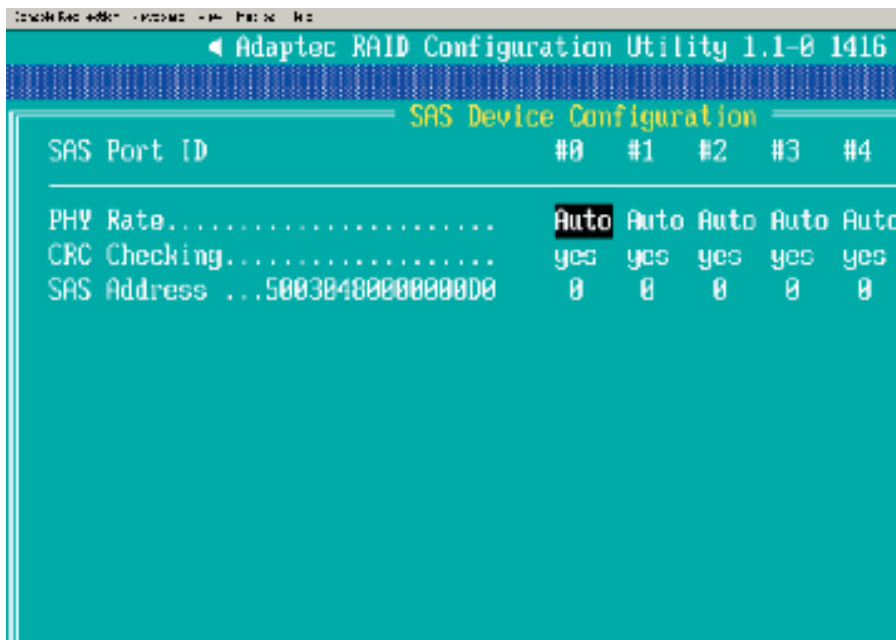

4. Use the arrow keys to select an item. Then, press <Enter> and the arrow keys to configure the item selected.
5. To load default settings, press <F6>.
6. Press <Esc> to return to the previous menu and to exit the utility.

Using the Disk Utilities

The Disk Utilities enable you to format or verify the media of your Serial ATA hard disks.

To access the disk utilities:

1. Turn on your computer and press **Ctrl+A** when prompted to access the Adaptec RAID Configuration Utility (as shown in the screen below.)

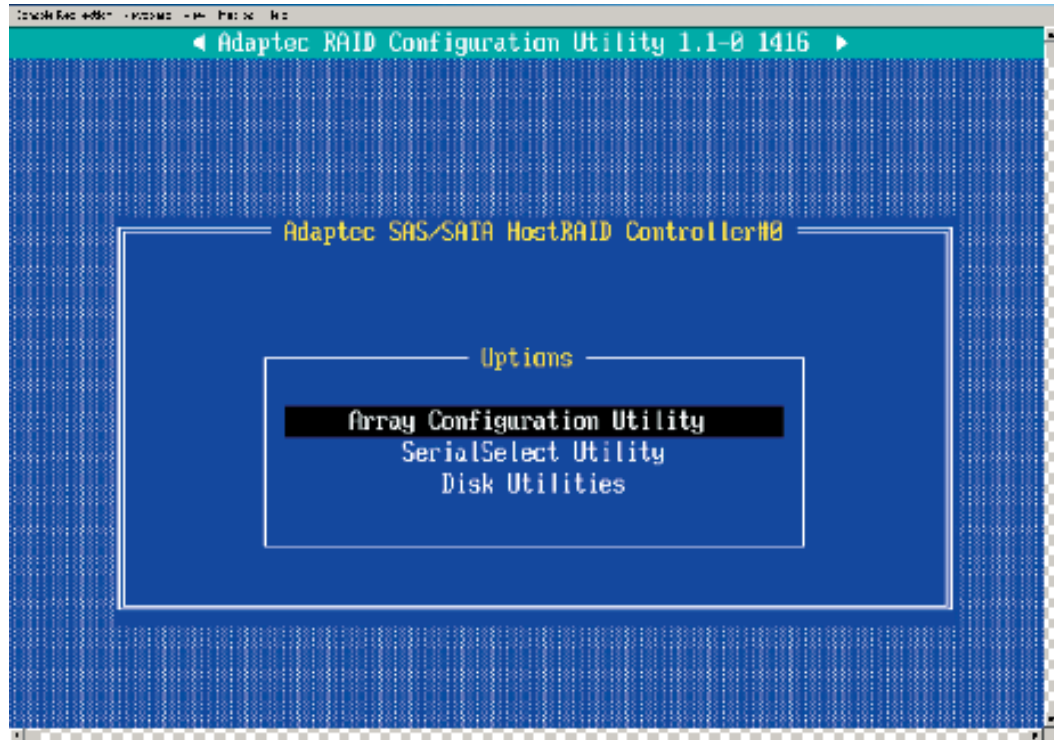

2. From the Adaptec RAID Configuration Utility menu, select **Disk Utilities** from the screen as shown above and press Enter.
3. When the submenu appears, select the desired disk and press **Enter**.

The following options are available:

1. **Format Disk**—Simulates a low-level format of the hard drive by writing zeros to the entire disk. (*Note: Serial ATA drives are low-level formatted at the factory and do not need to be low-level formatted again.)

(***Caution:** Formatting disk erases all data on the drive. Be sure to back up your data before performing this operation.)

2. **Verify Disk Media**—Scans the media of a disk drive for defects.

To Exit Adaptec RAID Configuration Utility

1. Once you have completed RAID array configurations, press **ESC** to exit. The following screen will appear.
2. Press **Yes** to exit the Utility.

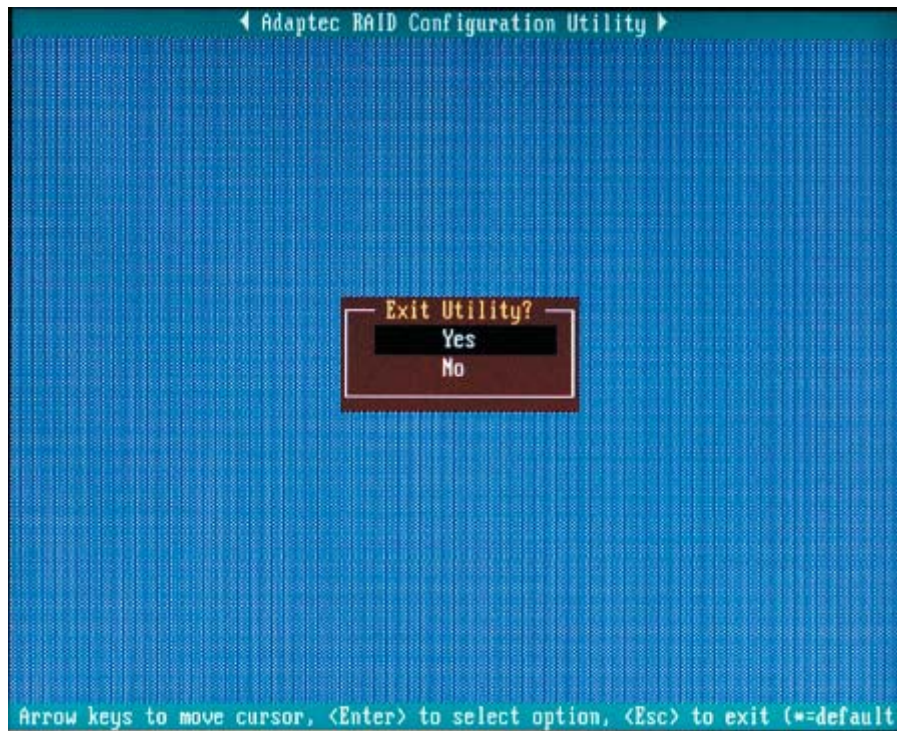

(*For more information regarding Adaptec RAID Utility, please refer to Adaptec's User's Guide in the CD included in your shipping package. You can also download a copy of Adaptec User's Guide from our web site at: www.supermicro.com.)

B-2 Installing the ICH5R/SAS Driver and the OS

- a. Insert Supermicro's bootable CD that came with the package into the CD Drive during the system reboot, and the screen: "Super Micro Driver Diskette Maker" will appear.
- b. From the list displayed on the screen, choose the item: "Intel 6300 ESB/ICH5R Driver by 3rd Party (Adaptec)" or "SAS" and press <ENTER>.
- c. From the next screen displayed, choose the OS driver you want to install and press <Enter>.
- d. Insert a formatted diskette into drive A: and press <Enter> as prompted.
- e. Exit the program after the process is completed. Then, reboot the system.
- f. Insert Microsoft Windows OS Setup CD in the CD Driver, and the system will start to boot up from CD.
- g. Press the <F6> key when the message-"Press F6 if you need to install a third party SCSI or RAID driver" displays.
- h. When the Windows OS Setup screen appears, press "S" to specify additional device(s).
- i. Insert the driver diskette-"Adaptec Embedded Serial ATA Raid Controller Driver" into Drive A: and press the <Enter> key.
- j. Choose Adaptec Embedded Host Serial ATA Raid Controller from the list indicated in the Windows OS Setup Screen, and press the <Enter> key.
- k. Press the <Enter> key to continue the installation process. (If you need to specify any additional devices to be installed, do it at this time.) Once all devices are specified, press the <Enter> key to continue with the installation.
- l. From the Windows OS Setup screen, press the <Enter> key. The OS Setup will automatically load all device files, and, then, continue the Windows OS installation.
- m. After Windows OS Installation is completed, the system will automatically reboot.

B-3 Installing Other Software Programs and Drivers

A. Installing Drivers other than Adaptec Embedded Serial ATA RAID Controller Driver

After you've installed Windows Operating System, a screen as shown below will appear. You are ready to install software programs and drivers that have not yet been installed. To install these software programs and drivers, click the icons to the right of these items.

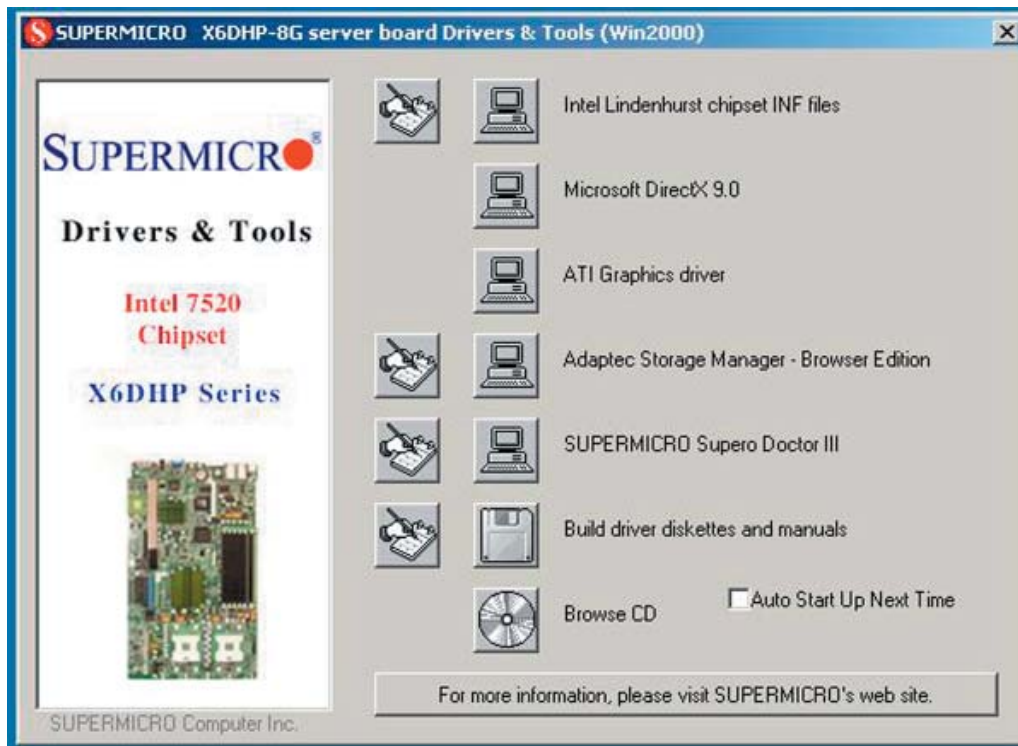

Driver/Tool Installation Display Screen

(*Note: Click the icons showing a hand writing on paper to view the readme files for each item. Click the computer icons to the right of these items to install each item (from top to the bottom) one at a time. **After installing each item, you must re-boot the system before moving on to the next item on the list.** You should install everything here except for the Supero Doctor utility, Intel LDCM and the LAN/SCSI driver diskettes, which are optional. The bottom icon with a CD on it allows you to view the entire contents of the CD.)

(*Please refer to the **Adaptec User's Guide for the installation of Adaptec's Serial ATA RAID Controller Driver. Adaptec's User's Guide is included in the CD. You can also download a copy of the user's guide from our web site.**)

Supero Doctor III

The Supero Doctor III program is a Web base management tool that supports remote management capability. It includes Remote and Local Management tools. The local management is called SD III Client. The Supero Doctor III program included on the CDROM that came with your motherboard allows you to monitor the environment and operations of your system. Supero Doctor III displays crucial system information such as CPU temperature, system voltages and fan status. See the Figure below for a display of the Supero Doctor III interface.

Supero Doctor III Interface Display Screen-I (Health Information)

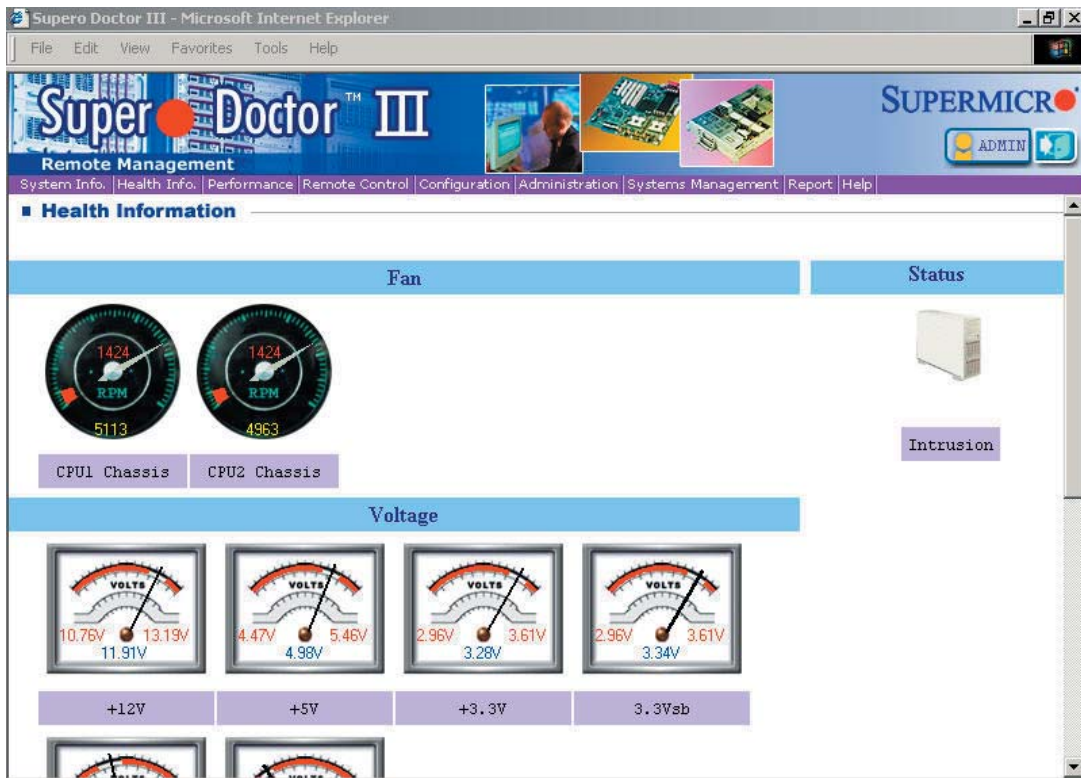

Supero Doctor III Interface Display Screen-II (Remote Control)

Graceful power control

Supero Doctor III allows a user to inform the OS to reboot or shut down within a specified time (the default is 30 seconds). Before the system reboots or shuts down, it's allowed to cancel the action.

Requirements

Keep Supero SD3Service Daemon running at all times on this system.
Provide TCP/IP connectivity.

Power control

(*Notes: 1. SD III Software Revision 1.0 can be downloaded from our Web site at: ftp://ftp.supermicro.com/utility/Supero_Doctor_III/. You can also download SDIII User's Guide at: <http://www.supermicro.com/PRODUCT/Manuals/SDIII/UserGuide.pdf>. For Linux, we will still recommend Supero Doctor II. 2. For detailed information on Adaptec's SCSI SATA RAID Utility, please refer to the CDs that came with your motherboard.)