

UP SuperServer SYS-510P-MR

1U Mainstream with 4 hot-swap 3.5" NVMe/SAS/SATA bays, 1 PCIe 4.0 x16 slot and redundant PSUs



More details here

Key Applications

Small Business, Web/Hosting Application, Email/Firewall/Print Server,

Key Features

- Single Socket P+ (LGA-4189) 3rd Gen Intel® Xeon® Scalable processors Up to 220W TDP.;
- 8 DIMMs; Supports 3DS DDR4-3200: RDIMM/LRDIMM/Intel® Intel® DCPMM;
- 1 PCIe 4.0 x16 (FHHL) slot;
- Intel® Ethernet Controller i350 2x 1GbE RJ45;
- 4x hot-swap 3.5" Hybrid SATA3/NVMe drive bays, SAS3 with additional SAS controller card; Onboard 2x NVMe/SATA M.2;
- Redundant Platinum 400W Power Supply;



Form Factor	1U Rackmount Enclosure: 437 x 43 x 507mm (17.2" x 1.7" x 19.98") Package: 609.6 x 215.9 x 749.3mm (24" x 8.5" x 29.5")
Processor	Single Socket P+ (LGA-4189) 3rd Gen Intel® Xeon® Scalable processors Up to 36C/72T; Up to 54MB Cache
GPU	Max GPU Count: Up to 1 single-width GPU Supported GPU: NVIDIA PCIe: T400 CPU-GPU Interconnect: PCIe 4.0 x16 CPU-to-GPU Interconnect
System Memory	Slot Count: 8 DIMM slots Max Memory (1DPC): Up to 2TB 3200MT/s ECC DDR4 RDIMM/LRDIMM Supports Intel® Optane™ persistent memory 200 series
Drive Bays Configuration	Default: Total 4 bays <ul style="list-style-type: none"> • 4 front hot-swap 3.5" PCIe 4.0 NVMe*/SAS*/SATA drive bays (*NVMe/SAS support may require additional storage controller and/or cables) M.2: 2 M.2 PCIe 3.0 x4 NVMe/SATA slots (M-key 2280/22110) Peripheral Bays: 2 2.5" bays (optional)
Expansion Slots	Default <ul style="list-style-type: none"> • 1 PCIe 4.0 x16 FHHL slot
On-Board Devices	SATA: SATA (6Gbps) ; RAID 0/1/5/10 support NVMe: NVMe; RAID 0/1/5/10 support(VROC HW key required) Chipset: Intel® C621A Network Connectivity: 2 RJ45 1GbE with Intel® I350
Input / Output	LAN: 2 RJ45 1 GbE LAN ports 1 RJ45 1 GbE Dedicated BMC LAN port (IPMI shared on LAN port 1) USB: 4 USB 2.0 ports(header) 2 USB 3.2 Gen1 Type-A ports(rear) 2 USB 2.0 Type-A ports(rear) 2 USB 3.2 Gen1 ports(Header) 1 USB 3.2 Gen1 Type-A port Video: 1 VGA port Serial: 1 COM port(Rear) 1 COM port(Header) DOM: 2 SuperDOM (Disk on Module) portswith built-in power TPM: 1 TPM header

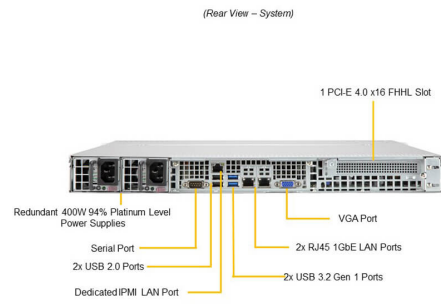
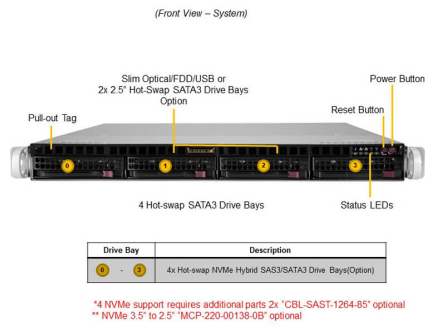

System Cooling	Fans: 4 middle cooling PWM 40x40x28mm Fan(s) 2 AOC cooling Fan(s) (optional) Air Shroud: 1 Air Shroud
Power Supply	2x 400W Redundant (1 + 1) Platinum Level (94%) power supplies
System BIOS	BIOS Type: AMI 32MB SPI Flash EEPROM
Management	SuperCloud Composer®; Supermicro Server Manager (SSM); Supermicro Update Manager (SUM); Supermicro SuperDoctor® 5 (SD5); Super Diagnostics Offline (SDO); Supermicro Thin-Agent Service (TAS); SuperServer Automation Assistant (SAA) New!
PC Health Monitoring	CPU: Monitors for CPU Cores, Chipset Voltages, Memory 7+1 Phase-switching voltage regulator FAN: Fans with tachometer monitoring Status monitor for speed control Pulse Width Modulated (PWM) fan connectors Temperature: Monitoring for CPU and chassis environment Thermal Control for fan connectors
Dimensions and Weight	Weight: Gross Weight: 30.4 lbs (13.8 kg) Net Weight: 17.6 lbs (8 kg) Available Color: Black
Operating Environment	Operating Temperature: 10°C to 35°C (50°F to 95°F) Non-operating Temperature: -40°C to 70°C (-40°F to 158°F) Operating Relative Humidity: 8% to 90% (non-condensing) Non-operating Relative Humidity: 5% to 95% (non-condensing)
Motherboard	Super X12SPO-F
Chassis	CSE-813MF2TS-R407CBP2