

**CONTACT INFORMATION**

- www.supermicro.com (Email: support@supermicro.com)
- Manuals: <http://www.supermicro.com/support/manuals>
- Drivers & Utilities: <ftp://ftp.supermicro.com>
- Safety: [http://www.supermicro.com/about/policies/safety\\_information.cfm](http://www.supermicro.com/about/policies/safety_information.cfm)

**PACKAGE CONTENTS** (Applies to individual-pack only)

- One (1) Supermicro Motherboard
- Six (6) SATA Cables
- One (1) I/O Shield
- One (1) Quick Reference Guide

**Motherboard Layout and Features**

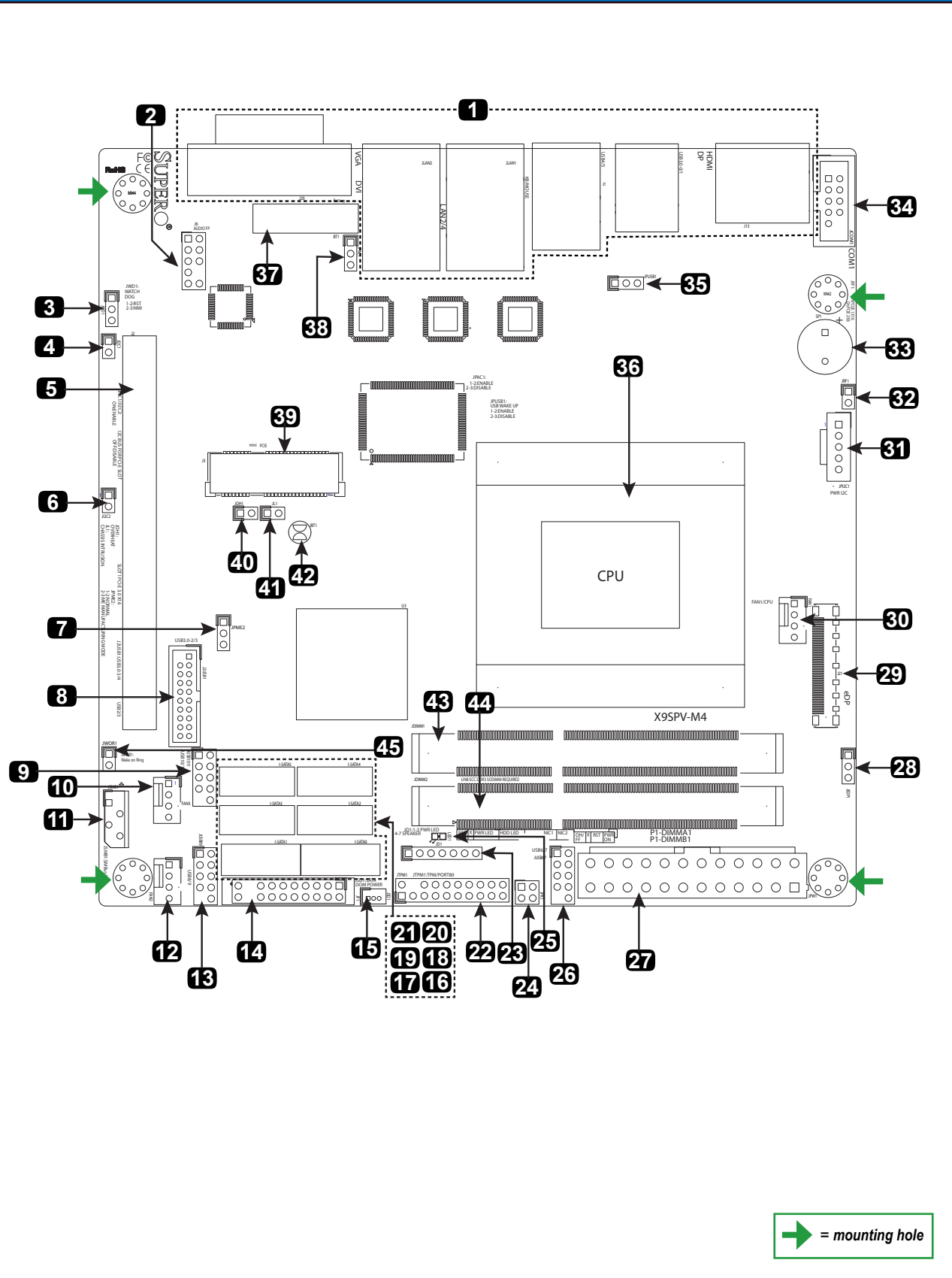

**Jumpers, Connectors and LED Indicators**

Jumpers			
Item #	Jumper	Description	Default
3	JWD1	Watch Dog Timer Reset/NMI	Pins 1-2 (Reset)
4,6	JI2C1/JI2C2	I2C Bus for PCI-E Slot	Open (Disabled)
7	JPME2	ME Manufacturing Mode	Pins 1-2 (Normal)
28	JEDP1	eDP Port Voltage Select	Pins 2-3 (3.3V)
32	JRF1	PCI-E Select (1X16 or 2X8)	Short (1X16)
35	JPUSB1	USB Wake-Up Enable/Disable	Pins 1-2 (Disabled)
38	JPAC1	Audio Enable/Disable	Pins 1-2 (Enabled)
42	JBT1	CMOS Reset	Short contact pads to reset CMOS

Connectors		
Item #	Connector	Description
1	Back Panel I/O	Please see "Back Panel IO Connectors" below, right
2	AUDIO FP	Front Panel Audio Header
5	SLOT1	PCI-E 3.0 X16 Slot
8	USB 2/3	USB Header for USB Ports 2/3 (USB 3.0)
9, 13, 26	USB 10/11,8/9,6/7	USB Headers for USB Ports 10/11,8/9,6/7 (USB 2.0)
10, 12, 30	FAN 3,2,1	System Fan Headers (FAN1: CPU Fan)
11	JSMB1	4-pin External I2C Header from PCH
14	JF1	Front Control Panel Header (see illustration on right)
15	JSD1	Disk On Module (DOM) Power Header
16~21	I-SATA0~5	SATA Ports 0~5
22	JTPM1	Trusted Platform Module (TPM) Header
23	JD1	Pins 1-3 Power LED Header, 4-7 External Speaker
24	JPK1	LAN3 and LAN4 Activity LED Header (Yellow)
27	JPW1	24-pin ATX Power Header
29	eDP	Embedded DisplayPort
31	JPI2C1	PWR supply (I2C) System Management Bus
33	SP1	Internal Speaker/Buzzer
34	JCOM1	Internal Serial Port (COM1)
36	CPU	X9SPV-M4: i7-3555LE, 25W, Dual Core X9SPV-M4-3QE: i7-3612QE, 35W, Quad Core X9SPV-M4-3UE: i7-3517UE, 17W, Dual Core
37	BT1	System Battery
39	Mini PCIE	Mini PCI-E Slot
40	JOH1	Overheat LED Header
41	JL1	Chassis Intrusion Header
43, 44	DIMMA1, DIMMB1	Vertical SO DIMM Slots (ECC DDR3, 1600/1333MHz)
45	JWOR1	Wake-On-Ring Header

LED Indicators				
Item #	LED	Description	Color/State	Status
25	LED1	Power LED	Green/Solid	System On/Running

**Memory Support**

This motherboard supports up to 16 GB of DDR3/DDR3L ECC SODIMMs in 2 SO-DIMM slots. It supports speeds of up to 1600MHz for DDR3 and up to 1333MHz for DDR3L (low power).

**Note:** For memory optimization, use only SODIMM modules that have been validated by Supermicro. For the latest memory updates, please refer to our website at <http://www.supermicro.com/products/motherboard>.

**DIMM Installation**

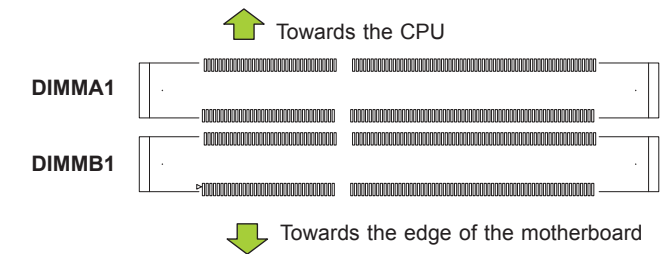

**Memory Population Guidelines**

When installing memory modules, the DIMM slots should be populated in the following order: DIMMA1, DIMMB1

**Front Control Panel (JF1)**

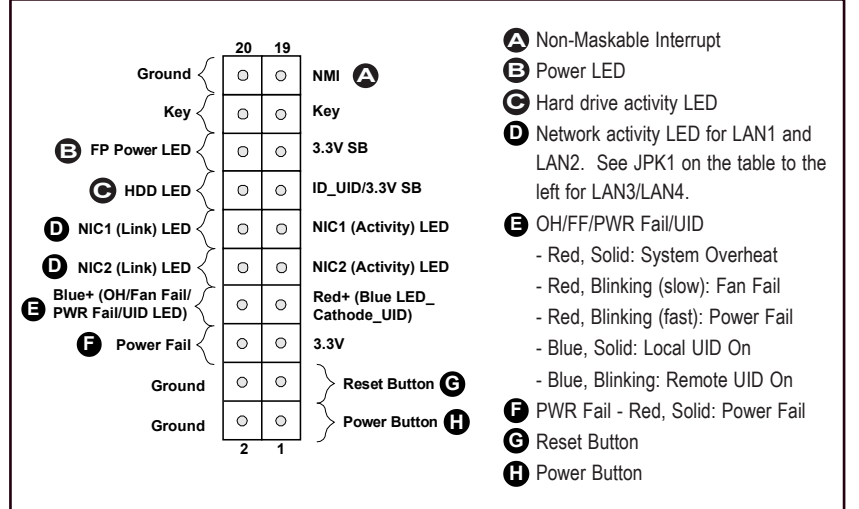

**Back Panel IO Connectors**

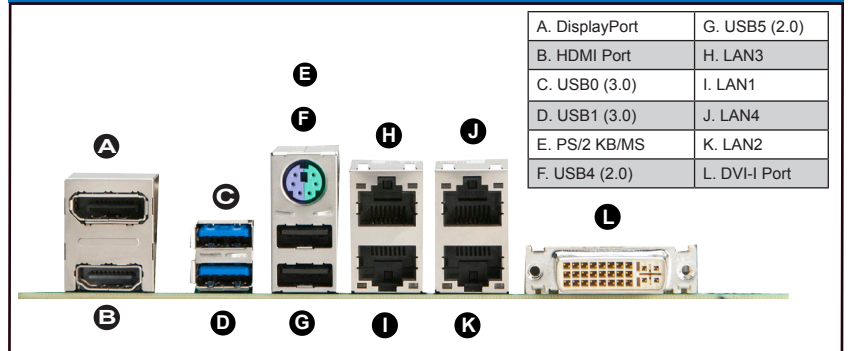

**Note:** Graphics shown in this quick reference guide are for illustration only. Your components may or may not look exactly the same as drawings shown in this guide.

**Note:** Refer to Chapter 2 of the User Manual for detailed information on jumpers, connectors, and LED indicators.

**Note:** Refer to Chapter 2 of the User Manual for detailed information on memory support and CPU/motherboard installation instructions.