



WEEE DISASSEMBLY INSTRUCTIONS

SUPERMICRO SYS-221BT-DNTR ENCLOSURE

Abstract

This document provides clear guidance for end-of-life recyclers on how to identify and disassemble reportable materials in compliance with the Waste Electrical and Electronic Equipment (WEEE) directive.

Table of Contents

1. Product Views.....	1
2. Reportable Materials on SYS-221BT-DNTR.....	3
3. Disassemble Instructions	4
3.3 Step-by-Step Disassembly Instructions	7
1. Removing Cable and Chassis Top Cover	7
2. Removing Hard Disk Drive (HDDD) / Solid State Drive (SDD).....	8
3. Removing Power Supply	9
4. Removing Power Distributor.....	10
5. Removing Backplane	11
6. Removing Fan	11
7. Removing AIOM Card	12
8. Removing the Air shroud, Riser, and the Riser Bracket	13
9. Removing Processor	14
10. Removing DIMM.....	15
11. Removing Storage Controller Card and M.2.....	16
12. Removing Motherboard.....	16
13. Removing Control Panel.....	17

1. Product Views

Front view



Rear view



Product construct view



Hard Disk Drive/ Solid State Drive



Node B

Node A

Power Supply



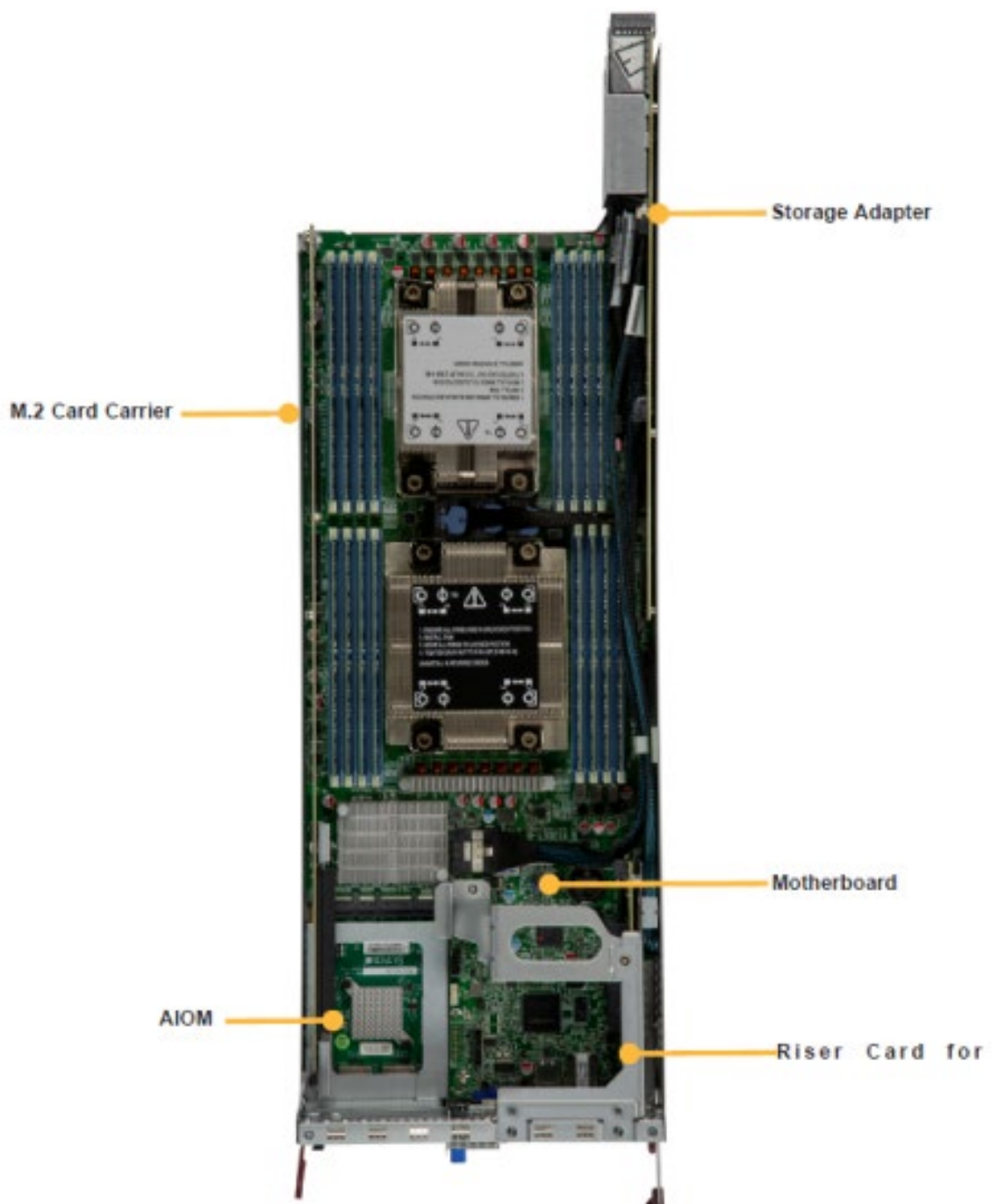

2. Reportable Materials on SYS-221BT-DNTR

According to Article 8(2) and Annex VII of WEEE directive 2012/19/EU, below materials and components should be selectively treated.

Description	Notes	No.	Quantity
Printed Circuit Boards (PCB) or Printed Circuit Assemblies (PCA)	With a surface greater than 10 sq cm (Depending on the configuration)	2.4,3.5,4.2,5.1, 7.3, 8.2, 9.2,10.1, ,11.1,11.2,12.1,	46
Batteries	All types, including standard alkaline and lithium coin or button style batteries	12.2	2
Mercury-containing components	For example, mercury in lamps, display backlights, scanner lamps, switches, batteries		
Liquid Crystal Displays (LCD) with a surface greater than 100 sq cm	Includes background illuminated displays with gas discharge lamps		
Cathode Ray Tubes (CRT)			
Capacitors / condensers (Containing PCB/PCT)			
Electrolytic Capacitors / Condensers measuring greater than 2.5 cm in diameter or height	Depending on the power supply model	3.6	2
External electrical cables and cords		1.1	2
Gas Discharge Lamps			
Plastics containing Brominated Flame Retardants		13.2,13.2	4
Components and parts containing toner and ink, including liquids, semi-liquids (gel/paste), and toner	Include the cartridges, print heads, tubes, vent chambers, and service stations.		
Components and waste containing asbestos			
Components, parts, and materials containing refractory ceramic fibers			
Components, parts, and materials containing radioactive substances			



3. Disassemble Instructions

The intent of this document is to provide guidance to recyclers on the presence of materials and components at the product / family level, as required by the EU WEEE Directive 2012/10/EU. This document should also help direct recyclers to proper methods for removing parts and general product disassembly instructions.

This chapter consists of three subsections:

Recommended disassembly tools, disassembled flowchart, and step-by-step disassembly instructions to direct recycler proper methods to treat.

3.1 Recommended Disassembly Tools





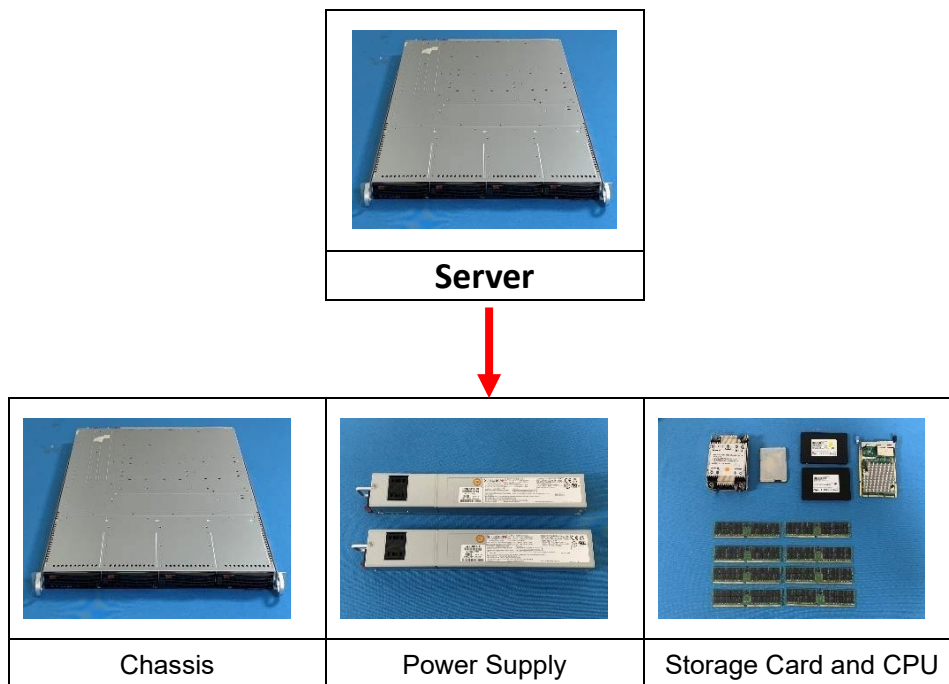

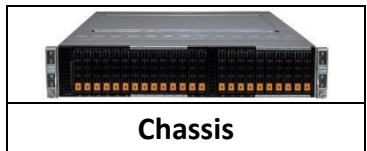

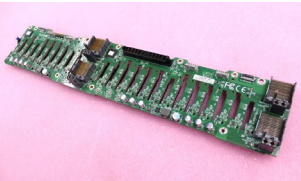

Disassembly tool	T30-bit screwdriver	
	Cross screwdriver	
	Flathead screwdriver	

3.2 Disassembled flowchart



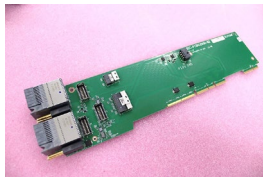

Chassis

			
<p>Backplane</p>	<p>Air Shroud *2</p>	<p>Sponge</p>	<p>Fan</p>
			
<p>Screw, Stand-off</p>	<p>Motherboard</p>	<p>Storage Controller Card *2</p>	<p>Storage Controller Card *2</p>
			
<p>Riser Card*2</p>	<p>Cable</p>	<p>Battery</p>	



Power Enclosure*2	Screw and Standoff*2 Set	Power Supply Module*2	Power Distributor*1

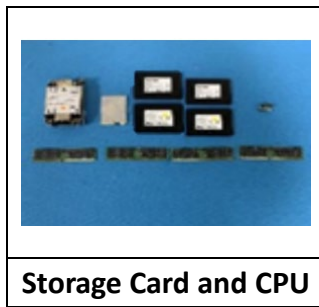

Heat Sink *4Set	Processor* 2Set	SSD * 4set
AIOM *4	DIMM *4Set	Power Cable
M.2 *8	Hard Drive * 8	

3.3 Step-by-Step Disassembly Instructions

1. Removing Cable and Chassis Top Cover

1. Use the operating system to power down the system.
2. After the system has completely shutdown, disconnect the power cords from the power supply modules.
3. Remove all cables/ unit from the server IO port.

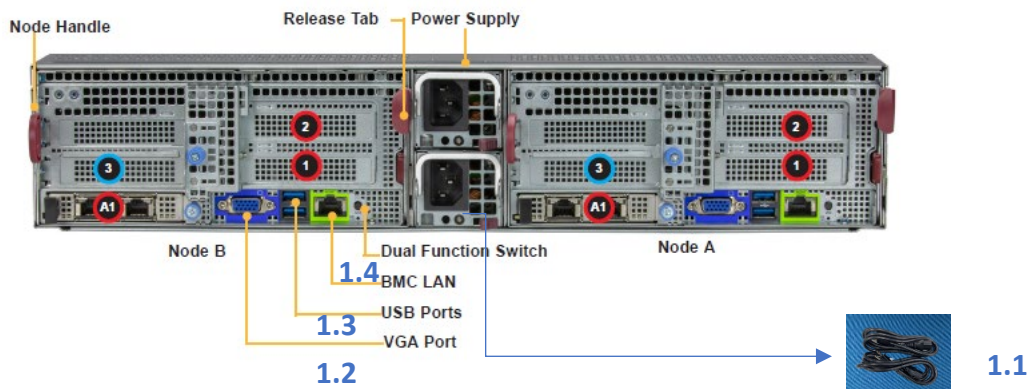

4. The chassis top cover can be lifted off after removing two screws.

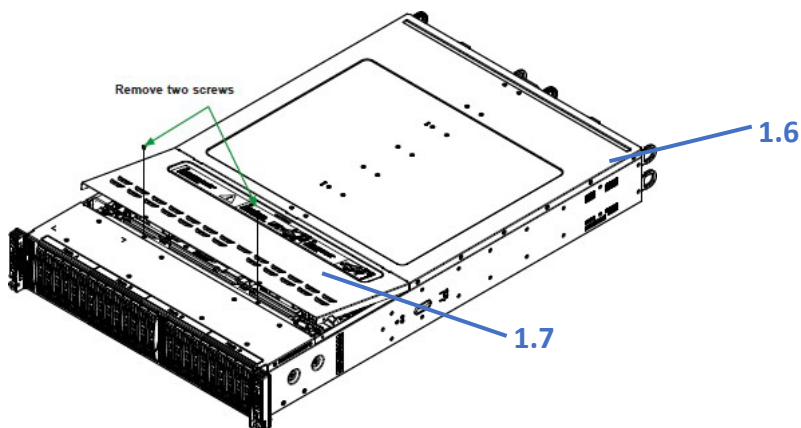

No.	Description	No.	Description
1.1	Power Cable	1.6	Chassis
1.2	VGA Port	1.7	Top Cover
1.3	USB Port		
1.4	BMC LAN		
1.5	LAN Port		

2. Removing Hard Disk Drive (HDDD) / Solid State Drive (SDD)

1. Push the release button on the drive carrier, which will extend the drive bay handle
2. Use the drive bay handle to pull the drive carrier out of the chassis

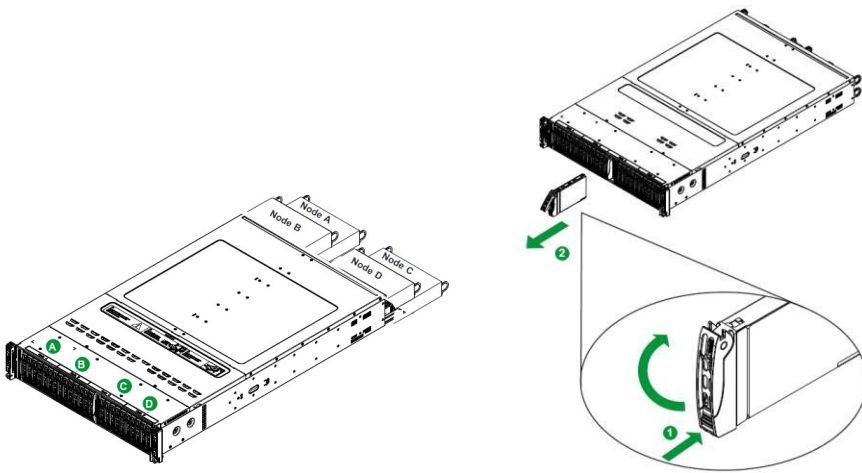

3. Remove the dummy tray insert by first removing two screws, then pull out the dummy tray

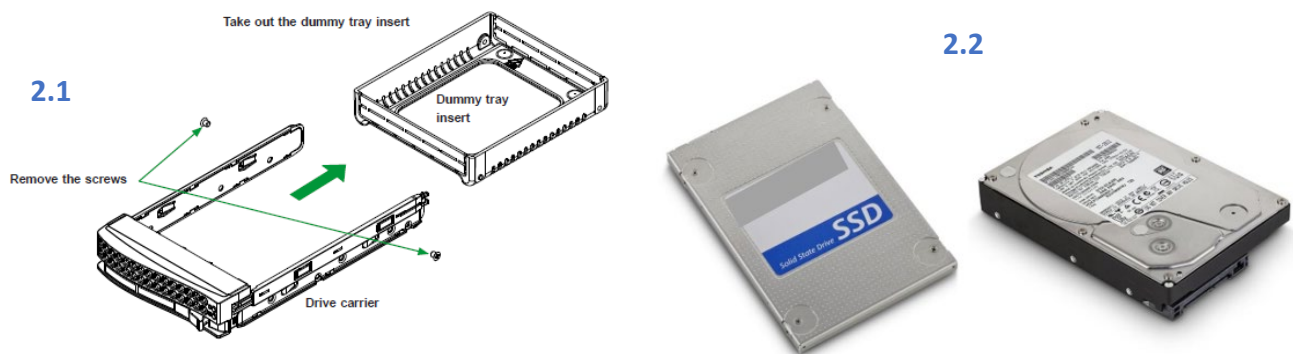

5. Use a cross screwdriver to remove drive enclosure

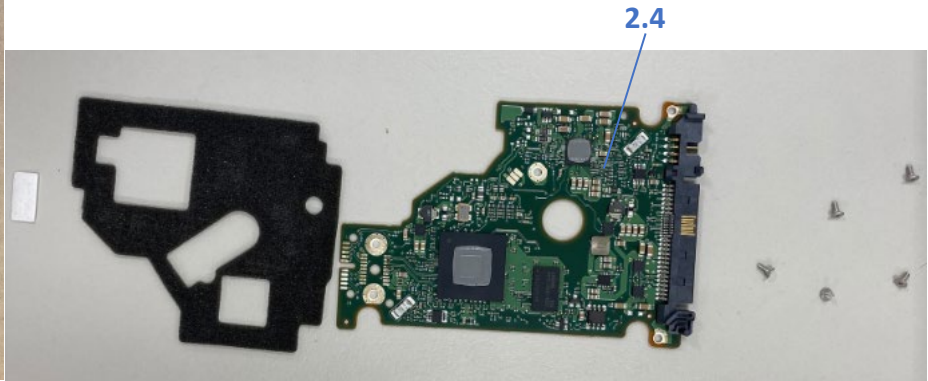

6. Use a cross screwdriver to remove screws and lift off the PCB

No.	Description
2.1	Dummy Tray
2.2	HDD/ SSD
2.3	Hard Drive Enclosure
2.4	Hard Drive PCB

3. Removing Power Supply

1. Press the release tab on the failed power supply.
2. Use the handle to gently slide the power supply out the back of the chassis.

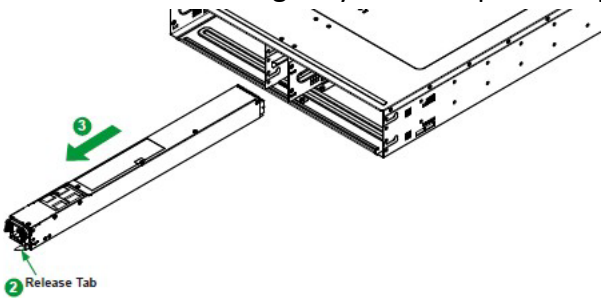

3. Remove the screw from the enclosure



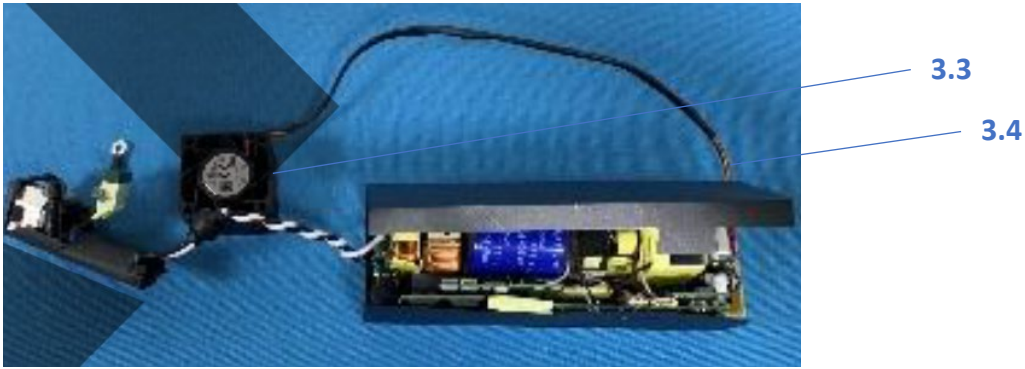

4. Cut the power leads connected to the fan and lift the main board from the chassis



No.	Description
3.1	Power Supply
3.2	Power Enclosure
3.3	Fan
3.4	Fan Cable
3.5	Power Module PCB
3.6	Capacitor

4. Removing Power Distributor

1. Disconnect the power cords from the power supply modules.
2. Remove 4 screws and lift out the power distributor from the chassis
3. Remove power distributor screw and standoff then take PCB from the power distributor.

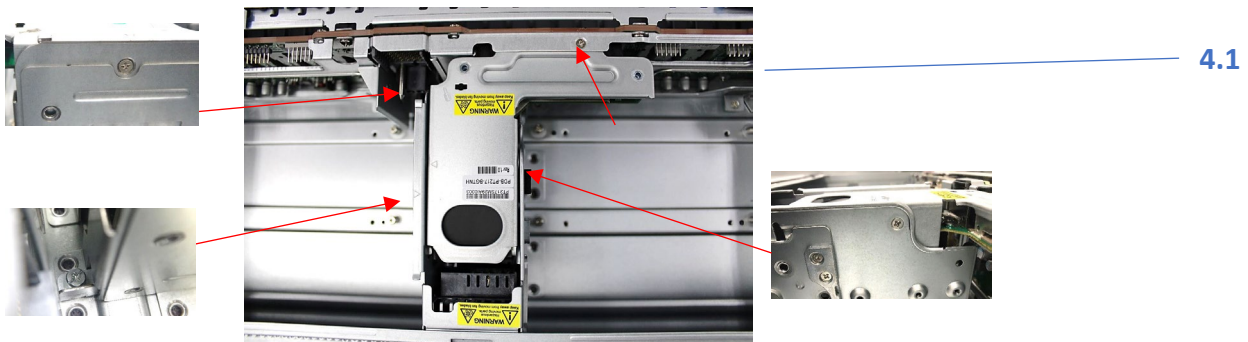

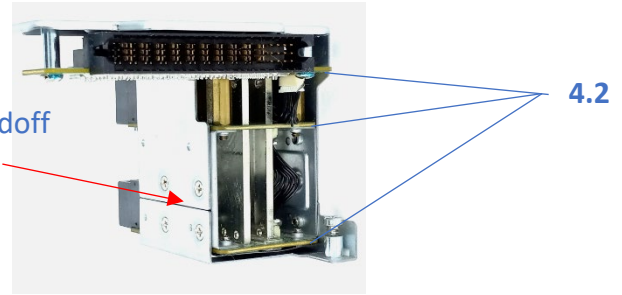
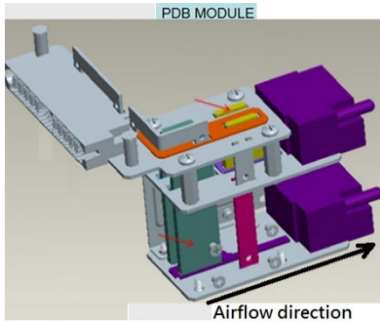

No.	Description
4.1	Power Distributor
4.2	Power Distributor PCB

5. Removing Backplane

1. Remove the backplane 8 screws from the chassis

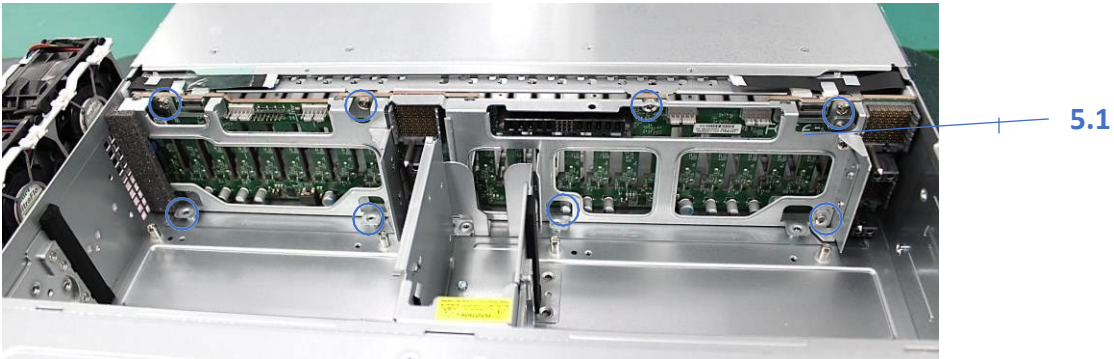

No.	Description
5.1	Backplane

6. Removing Fan

1. Remove the fan cable from the backplane for the failed fan and the adjacent fan.
2. Lift the fan housing up and out of the chassis.
3. Push the fan up from the bottom and out of the top of the housing.

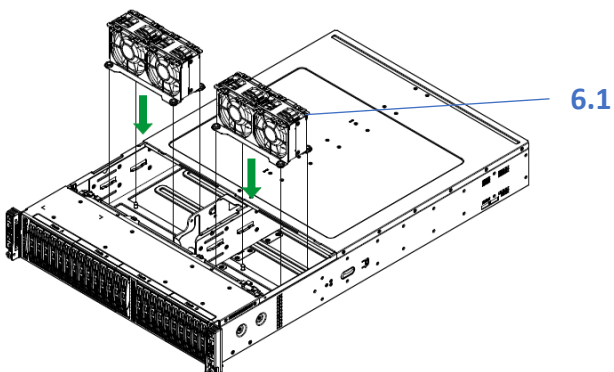

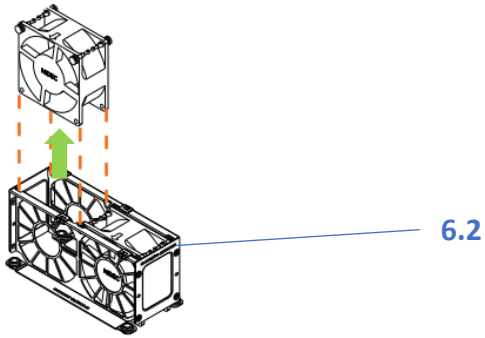

No.	Description
6.1	Cooling Fan
6.2	Fan Housing

7. Removing AIOM Card

1. Press the node holder, then hold the node and pull the node from the chassis
2. Press the release tab and loosen the thumbscrew on the AIOM card
3. Grasp the release tab and the thumbscrew and pull the AIOM out of the node tray
4. Grasp the release tab and the thumbscrew and pull the AIOM out of the node tray

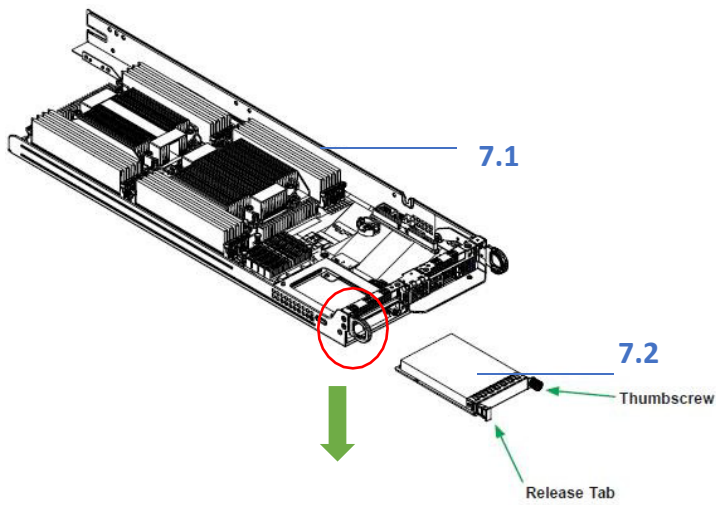

5. Press the pin and remove the pin and take the PCB from AIOM

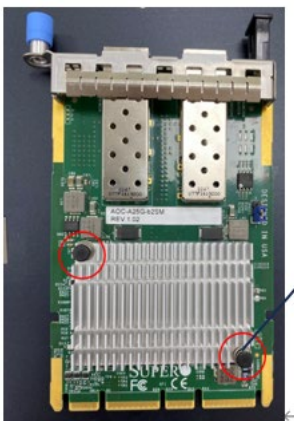

Press the pin



7.3

No.	Description
7.1	Node
7.2	AIOM Card
7.3	AIOM PCB

8. Removing the Air shroud, Riser, and the Riser Bracket

1. Remove screws each from the air shroud, lift it by hand.
3. Take the riser card and bracket away from the chassis

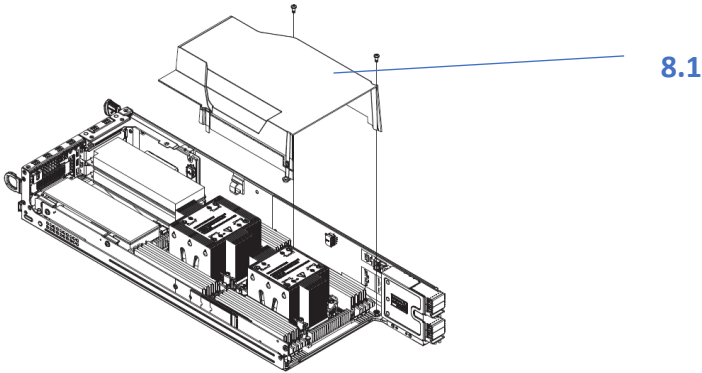

Removing the screw from riser card.

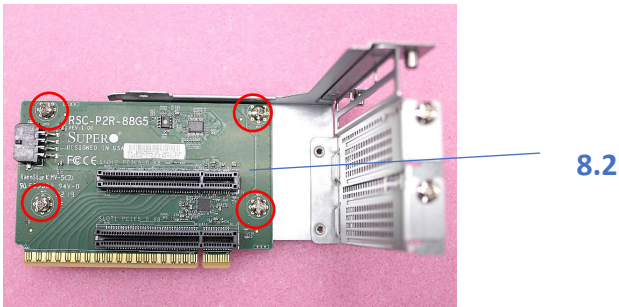

Removing the screw from riser bracket.

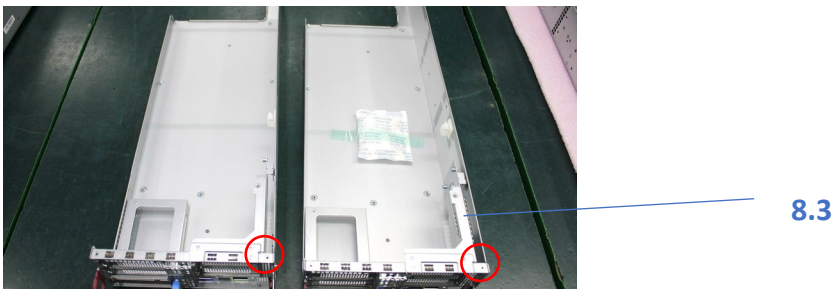

No.	Description
8.1	Air shroud
8.2	Riser Card
8.3	Riser Bracket

9. Removing Processor

1. Removing the PHM (Processor Heatsink Module) from the motherboard, first shut down the system and unplug the AC power cord from all power supplies
2. Use a T30-bit screwdriver to loosen the four peek nuts on the heatsink in the sequence of A, B, C, and D

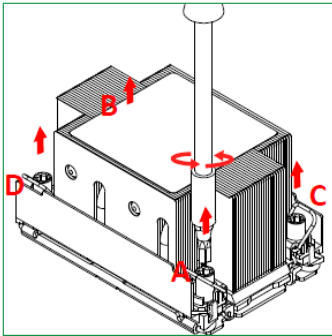

3. Once the peek nuts have been loosened from the CPU socket, press the rotating wires inward to unlatch the PHM from the socket, as shown below

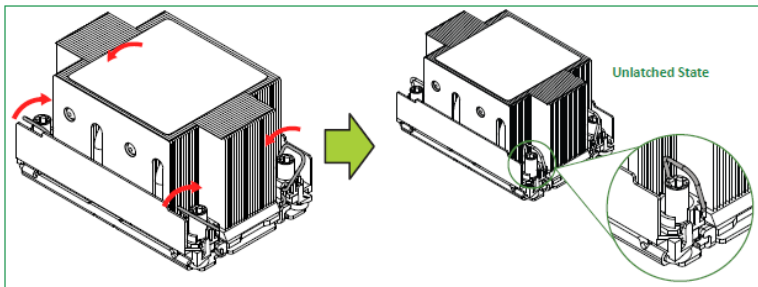

4. Gently lift the PHM upward to remove it from the CPU socket

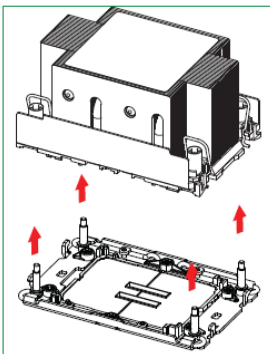

5. Use your hand to detach the four plastic clips (marked a, b, c, d) on the processor carrier assembly from the four corners of the heatsink (marked A, B, C, D), as shown below

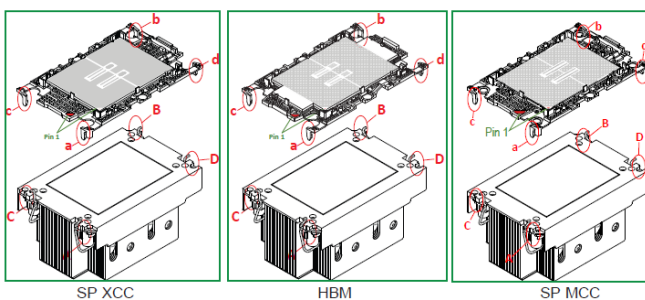

6. When all plastic clips have been detached from the heatsink, remove the processor carrier assembly from the heatsink

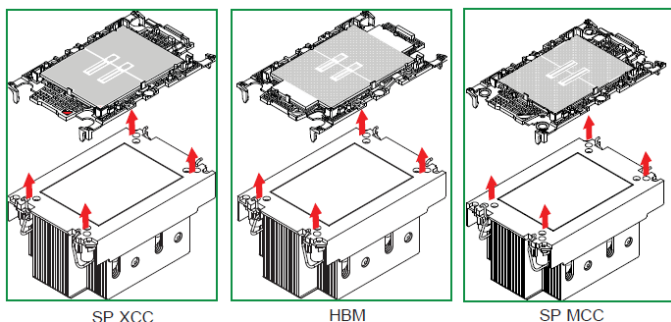

7. Unlock the lever from its locked position and push it upwards to disengage the processor from the processor carrier, as shown below right

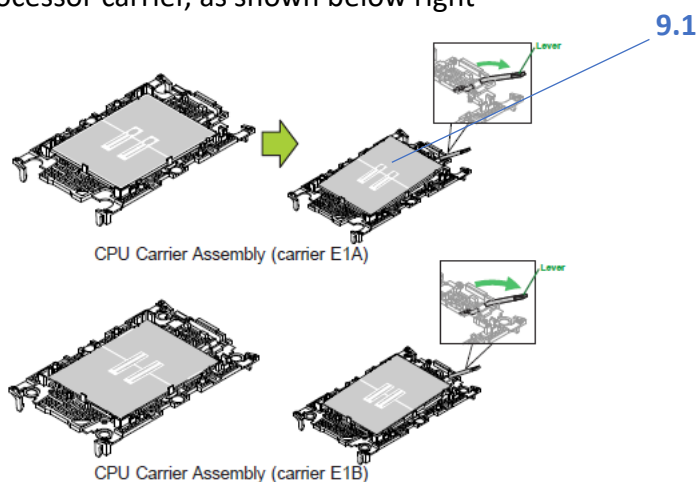

8. Once the processor has been loosened from the carrier, carefully remove the processor from the carrier

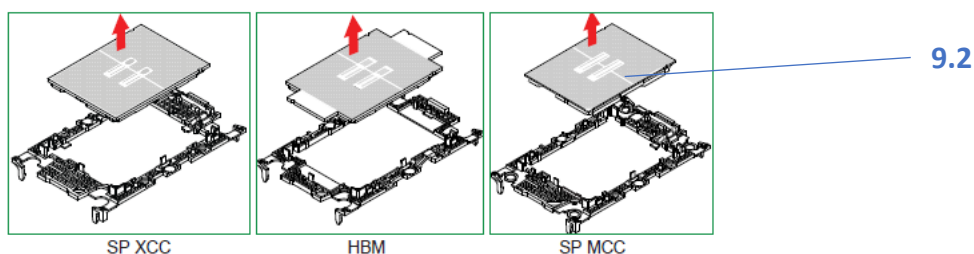

Note: Please handle the processor with care to avoid damaging it or its pins

No.	Description
9.1	Heat Sink
9.2	Processor

10. Removing DIMM

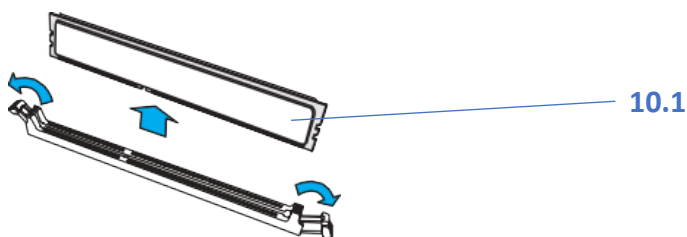

1. Hand press both release tabs on the ends of the DIMM module to unlock it
2. Once the DIMM module is loose, remove it from the memory slot

No.	Description
10.1	DIMM

11. Removing Storage Controller Card and M.2

1. Removing M.2 form controller card by hand.

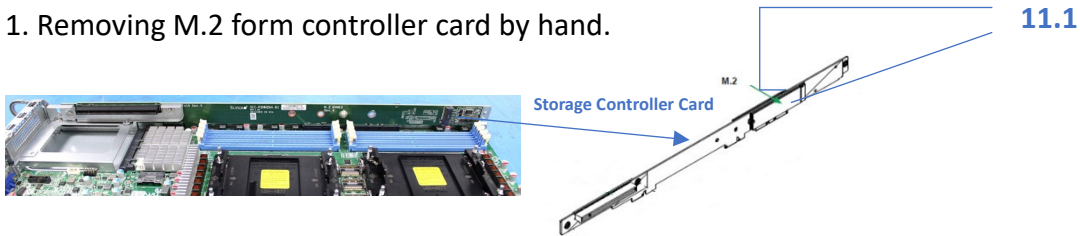

2. Removing the screw(in the red frame) from chassis them take 3pcs controller card.

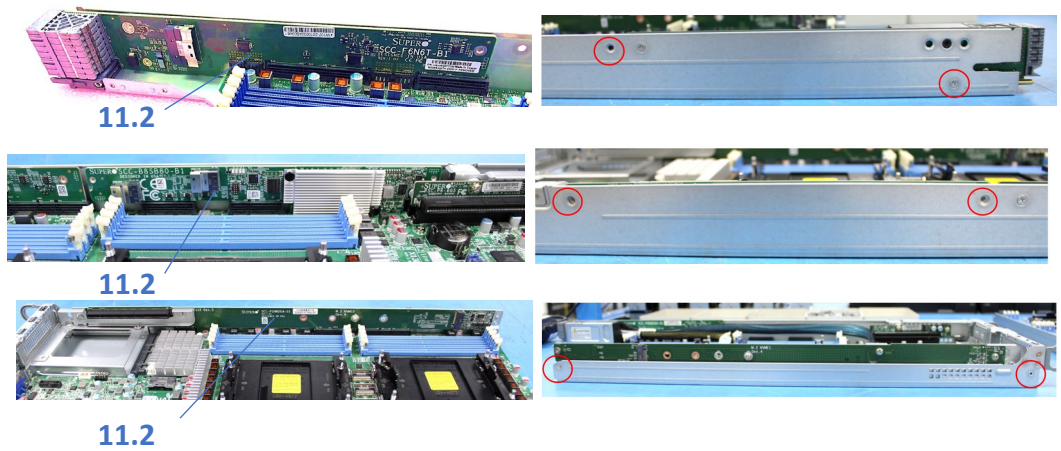

No.	Description
11.1	M.2
11.2	Storage Controller Card

12. Removing Motherboard

1. Remove screws, lift out motherboard
2. Push aside the small clamp that covers the edge of the battery. When the battery is released, lift it out of the holder
3. When the motherboard is removed, the node enclosure can be recycled

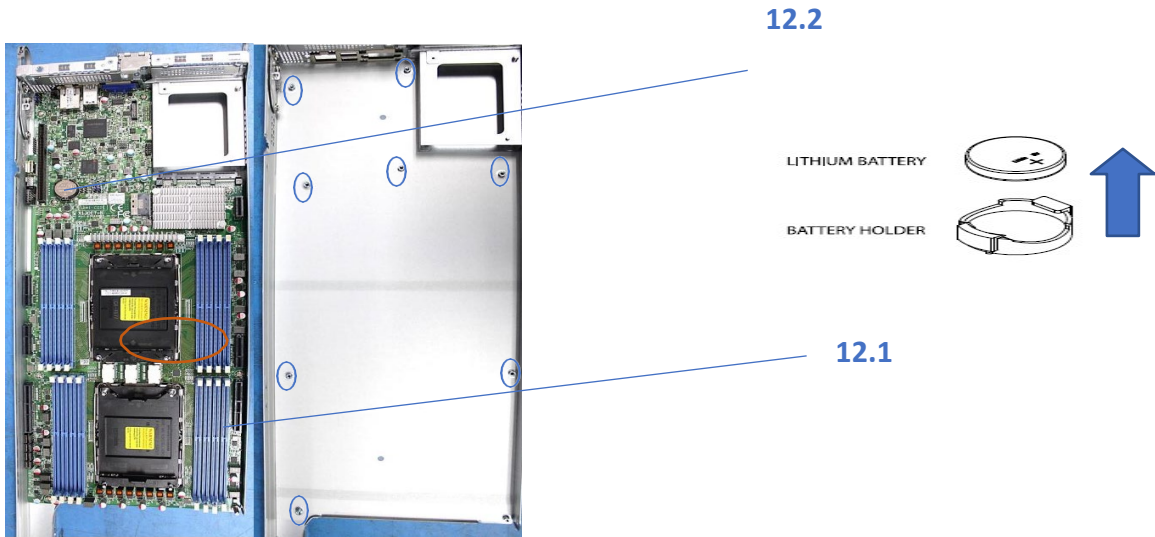

No.	Description
12.1	Motherboard
12.2	Battery

Note: Repeat steps 1-12 of each node(A,B,C,D) disassembled, then the chassis enclosure can be recycled

13. Removing Control Panel

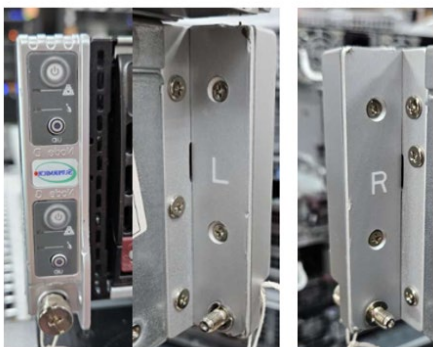

Remove control panel screw (R and L) from chassis



Remove basket screw and hand screw (R and L) from control panel and used hand remove basket mylar.

No.	Description
13.1	Control Panel Cover L & R
13.2	MYLAR_L & R