

SUPERO[®]

SC818G Chassis Series

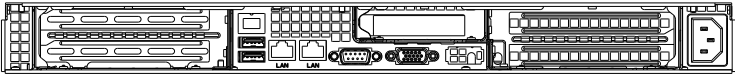

SC818G-1400B

USER'S MANUAL

1.0

The information in this User's Manual has been carefully reviewed and is believed to be accurate. The vendor assumes no responsibility for any inaccuracies that may be contained in this document, makes no commitment to update or to keep current the information in this manual, or to notify any person or organization of the updates. **Please Note: For the most up-to-date version of this manual, please see our web site at www.supermicro.com.**

Super Micro Computer, Inc. ("Supermicro") reserves the right to make changes to the product described in this manual at any time and without notice. This product, including software, if any, and documentation may not, in whole or in part, be copied, photocopied, reproduced, translated or reduced to any medium or machine without prior written consent.

IN NO EVENT WILL SUPERMICRO BE LIABLE FOR DIRECT, INDIRECT, SPECIAL, INCIDENTAL, SPECULATIVE OR CONSEQUENTIAL DAMAGES ARISING FROM THE USE OR INABILITY TO USE THIS PRODUCT OR DOCUMENTATION, EVEN IF ADVISED OF THE POSSIBILITY OF SUCH DAMAGES. IN PARTICULAR, SUPERMICRO SHALL NOT HAVE LIABILITY FOR ANY HARDWARE, SOFTWARE, OR DATA STORED OR USED WITH THE PRODUCT, INCLUDING THE COSTS OF REPAIRING, REPLACING, INTEGRATING, INSTALLING OR RECOVERING SUCH HARDWARE, SOFTWARE, OR DATA.

Any disputes arising between manufacturer and customer shall be governed by the laws of Santa Clara County in the State of California, USA. The State of California, County of Santa Clara shall be the exclusive venue for the resolution of any such disputes. Super Micro's total liability for all claims will not exceed the price paid for the hardware product.

California Best Management Practices Regulations for Perchlorate Materials: This Perchlorate warning applies only to products containing CR (Manganese Dioxide) Lithium coin cells. "Perchlorate Material-special handling may apply. See www.dtsc.ca.gov/hazardouswaste/perchlorate"

WARNING: Handling of lead solder materials used in this product may expose you to lead, a chemical known to the State of California to cause birth defects and other reproductive harm.

Manual Revision 1.0
Release Date: July 31, 2009

Unless you request and receive written permission from Super Micro Computer, Inc., you may not copy any part of this document.

Information in this document is subject to change without notice. Other products and companies referred to herein are trademarks or registered trademarks of their respective companies or mark holders.

Copyright © 2009 by Super Micro Computer, Inc.
All rights reserved.

Printed in the United States of America

Preface

About This Manual

This manual is written for professional system integrators and PC technicians. It provides information for the installation and use of the SC818G 1U chassis. Installation and maintenance should be performed by experienced technicians only.

Supermicro's SC818 1U chassis features a unique and highly-optimized design for quad-processor platforms. The chassis is equipped with a 1400W power supply to support high-performance system components and eight high-speed heavy duty counter-rotating fans for optimal cooling. Quick release slide rails also available for HPC and datacenter use.

This document lists compatible parts available when this document was published. Always refer to the our Web site for updates on supported parts and configurations.

Manual Organization

Chapter 1: Introduction

The first chapter provides a checklist of the main components included with this chassis and describes the main features of the SC818G chassis. This chapter also includes contact information.

Chapter 2: System Safety

This chapter lists warnings, precautions, and system safety. You should thoroughly familiarize yourself with this chapter for a general overview of safety precautions that should be followed before installing and servicing this chassis.

Chapter 3: Chassis Components

Refer here for details on this chassis model including the fans, bays, airflow shields, and other components.

Chapter 4: System Interface

Refer to this chapter for details on the system interface, which includes the functions and information provided by the control panel on the chassis as well as other LEDs located throughout the system.

Chapter 5: Chassis Setup and Maintenance

Refer to this chapter for detailed information on this chassis. You should follow the procedures given in this chapter when installing, removing, or reconfiguring your chassis.

Chapter 6: Rack Installation

Refer to this chapter for detailed information on chassis rack installation. You should follow the procedures given in this chapter when installing, removing or reconfiguring your chassis into a rack environment.

Appendices

This section lists compatible cables, power supply specifications, and compatible backplanes. Not all compatible backplanes may be listed. Refer to our Web site for the latest compatible backplane information.

Appendix A: Chassis Cables and Accessories

Appendix B: Power Supply Specifications

Appendix C: SAS-818TQ Backplane Specifications

Table of Contents

Preface

About This Manual	iii
-------------------------	-----

Chapter 1 Introduction

1-1 Overview	1-1
1-2 Shipping List.....	1-1
1-3 Chassis Features	1-2
CPU.....	1-2
Hard Drives	1-2
I/O Expansion slots	1-2
Peripheral Drives.....	1-2
Other Features	1-2
1-4 Contacting Supermicro.....	1-3
1-5 Returning Merchandise for Service.....	1-4

Chapter 2 System Safety

2-1 Overview	2-1
2-2 Warnings and Precautions	2-1
2-3 Preparing for Setup.....	2-1
2-4 Electrical Safety Precautions	2-1
2-5 General Safety Precautions	2-2
2-6 System Safety	2-3

Chapter 3 Chassis Components

3-1 Overview	3-1
3-2 Components	3-1
Chassis.....	3-1
Backplane.....	3-1
Fans	3-1
Rack Mounting	3-1
Power Supply	3-2
Air Shroud	3-2
3-3 Where to get Replacement Components.....	3-2

Chapter 4 System Interface

4-1 Overview	4-1
4-2 Control Panel Buttons	4-2
4-3 Control Panel LEDs	4-2
4-4 Drive Carrier LEDs.....	4-4
SAS/SATA Drives	4-4

4-5	Overheating.....	4-5
Chapter 5 Chassis Setup and Maintenance		
5-1	Overview	5-1
5-2	Installation Procedures.....	5-1
	Procedures for Twin Motherboard Chassis.....	5-1
	General Maintenance.....	5-1
5-3	Removing the Chassis Cover	5-2
5-4	Removing and Installing Hard Drives	5-3
5-5	Peripheral Drive Installation.....	5-7
5-6	Motherboard Installation.....	5-8
	Permanent and Optional Standoffs.....	5-8
	Installing the Motherboard	5-9
	Expansion Card Setup.....	5-10
	Riser Card Bracket Installation with Twin Motherboards.....	5-13
5-7	Installing the Air Shroud.....	5-14
	Checking the Air Flow	5-15
5-8	System Fans	5-16
	Fan Numbering in the BIOS	5-16
	Maintaining System Fan Trays.....	5-17
5-9	Power Supply	5-19
	Power Supply Replacement.....	5-19
Chapter 6 Rack Installation		
6-1	Overview	6-1
6-2	Unpacking the System.....	6-1
6-3	Preparing for Setup.....	6-1
	Choosing a Setup Location.....	6-1
	Rack Precautions.....	6-2
	General Server Precautions.....	6-2
	Rack Mounting Considerations	6-3
	Ambient Operating Temperature	6-3
	Reduced Airflow	6-3
	Mechanical Loading	6-3
	Circuit Overloading.....	6-3
	Reliable Ground	6-3
6-4	Rack Mounting Instructions.....	6-4

Identifying the Sections of the Rack Rails	6-4
Installing the Inner Rail Extensions	6-5
Assembling the Outer Rails	6-6
Installing the Outer Rails onto the Rack	6-7
Installing and Removing the Chassis From the Rack	6-8
6-5 Installing the Server into a Telco Rack	6-9

Appendix A SC818G Chassis Cables and Accessories

Appendix B SC818G Power Supply Specifications

Appendix C SAS-818TQ Backplane Specifications

Notes

Chapter 1

Introduction

1-1 Overview

Supermicro's SC818G 1U chassis features a unique and highly-optimized design. The chassis is equipped with high efficiency power supply. High performance fans provide ample optimized cooling for FB-DIMM memory modules and 4 hot-swap drive bays offer maximum storage capacity in a 1U form factor.

1-2 Shipping List

Please visit the following link for the latest shipping lists and part numbers for your particular chassis model <http://www.supermicro.com/products/chassis/1U/?chs=818>

SC818G Chassis				
Model	CPU	HDD	I/O Slots	Power Supply
SC818G-1400B	DP/UP	3x SAS / SATA	4xFF + 1xLP or 2xGPU + 1xLP	1400W

1-3 Chassis Features

The SC818G 1U high-performance chassis includes the following features:

CPU

The SC818G chassis supports a DP or UP Dual-core Xeon processor. Please refer to the motherboard specifications pages on our website for updates on supported processors.

Hard Drives

The SC818G chassis features three drive bays for SAS/SATA drives. These drives are hot-swappable. Once setup correctly, these drives can be removed without powering down the server. In addition, these drives support SES2 (SAS/SATA).

I/O Expansion slots

Each SC818G chassis includes four full-height, full-length expansion slots or two double-width high-end graphics cards (GPU), plus one low-profile expansion slot or one double-width high-end graphics card, (with twin motherboards).

Peripheral Drives

Each SC818G chassis supports one slim DVD-ROM drive (optional) and one slim Floppy drive (optional). These drives allow you to quickly install or save data.

Other Features

Other onboard features are included to promote system health. These include eight cooling fans, a convenient power switch, a reset button, and LED indicators.

1-4 Contacting Supermicro

Headquarters

Address: Super Micro Computer, Inc.
980 Rock Ave.
San Jose, CA 95131 U.S.A.

Tel: +1 (408) 503-8000

Fax: +1 (408) 503-8008

Email: marketing@supermicro.com (General Information)
support@supermicro.com (Technical Support)

Web Site: www.supermicro.com

Europe

Address: Super Micro Computer B.V.
Het Sterrenbeeld 28, 5215 ML
's-Hertogenbosch, The Netherlands

Tel: +31 (0) 73-6400390

Fax: +31 (0) 73-6416525

Email: sales@supermicro.nl (General Information)
support@supermicro.nl (Technical Support)
rma@supermicro.nl (Customer Support)

Asia-Pacific

Address: Super Micro Computer, Inc.
4F, No. 232-1, Liancheng Rd.
Chung-Ho 235, Taipei County
Taiwan, R.O.C.

Tel: +886-(2) 8226-3990

Fax: +886-(2) 8226-3991

Web Site: www.supermicro.com.tw

Technical Support:
Email: support@supermicro.com.tw

Tel: 886-2-8226-1900

1-5 Returning Merchandise for Service

A receipt or copy of your invoice marked with the date of purchase is required before any warranty service will be rendered. You can obtain service by calling your vendor for a Returned Merchandise Authorization (RMA) number. When returning to the manufacturer, the RMA number should be prominently displayed on the outside of the shipping carton, and mailed prepaid or hand-carried. Shipping and handling charges will be applied for all orders that must be mailed when service is complete.

For faster service, RMA authorizations may be requested online (<http://www.supermicro.com/support/rma/>).

Whenever possible, repack the chassis in the original Supermicro carton, using the original packaging material. If these are no longer available, be sure to pack the chassis securely, using packaging material to surround the chassis so that it does not shift within the carton and become damaged during shipping.

This warranty only covers normal consumer use and does not cover damages incurred in shipping or from failure due to the alteration, misuse, abuse or improper maintenance of products.

During the warranty period, contact your distributor first for any product problems.

Chapter 2

System Safety

2-1 Overview

This chapter provides a quick setup checklist to get your chassis up and running. Following the steps in order given should enable you to have your chassis setup and operational within a minimal amount of time. This quick set up assumes that you are an experienced technician, familiar with common concepts and terminology.

2-2 Warnings and Precautions

You should inspect the box the chassis was shipped in and note if it was damaged in any way. If the chassis itself shows damage, file a damage claim with carrier who delivered your system.

Decide on a suitable location for the rack unit that will hold that chassis. It should be situated in a clean, dust-free area that is well ventilated. Avoid areas where heat, electrical noise and electromagnetic fields are generated.

You will also need it placed near at least one grounded power outlet. When configured, the SC818G chassis includes one power supply.

2-3 Preparing for Setup

The SC818G chassis includes a set of rail assemblies, including mounting brackets and mounting screws you will need to install the systems into the rack. Please read this manual in its entirety before you begin the installation procedure.

2-4 Electrical Safety Precautions

Basic electrical safety precautions should be followed to protect yourself from harm and the SC818G from damage:

- Be aware of the locations of the power on/off switch on the chassis as well as the room's emergency power-off switch, disconnection switch or electrical outlet. If an electrical accident occurs, you can then quickly remove power from the system.
- Do not work alone when working with high voltage components.

- Power should always be disconnected from the system when removing or installing main system components, such as the serverboard, memory modules and the DVD-ROM and floppy drives (not necessary for hot swappable drives). When disconnecting power, you should first power down the system with the operating system and then unplug the power cords from all the power supply modules in the system.
- When working around exposed electrical circuits, another person who is familiar with the power-off controls should be nearby to switch off the power, if necessary.
- Use only one hand when working with powered-on electrical equipment. This is to avoid making a complete circuit, which will cause electrical shock. Use extreme caution when using metal tools, which can easily damage any electrical components or circuit boards they come into contact with.
- Do not use mats designed to decrease electrostatic discharge as protection from electrical shock. Instead, use rubber mats that have been specifically designed as electrical insulators.
- The power supply power cord must include a grounding plug and must be plugged into grounded electrical outlets.
- Serverboard battery: CAUTION - There is a danger of explosion if the onboard battery is installed upside down, which will reverse its polarities. This battery must be replaced only with the same or an equivalent type recommended by the manufacturer. Dispose of used batteries according to the manufacturer's instructions.
- DVD-ROM laser: CAUTION - this server may have come equipped with a DVD-ROM drive. To prevent direct exposure to the laser beam and hazardous radiation exposure, do not open the enclosure or use the unit in any unconventional way.

2-5 General Safety Precautions

- Keep the area around the chassis clean and free of clutter.
- Place the chassis top cover and any system components that have been removed away from the system or on a table so that they won't accidentally be stepped on.

- While working on the system, do not wear loose clothing such as neckties and unbuttoned shirt sleeves, which can come into contact with electrical circuits or be pulled into a cooling fan.
- Remove any jewelry or metal objects from your body, which are excellent metal conductors that can create short circuits and harm you if they come into contact with printed circuit boards or areas where power is present.
- After accessing the inside of the system, close the system back up and secure it to the rack unit with the retention screws after ensuring that all connections have been made.

2-6 System Safety

Electrostatic discharge (ESD) is generated by two objects with different electrical charges coming into contact with each other. An electrical discharge is created to neutralize this difference, which can damage electronic components and printed circuit boards. The following measures are generally sufficient to neutralize this difference before contact is made to protect your equipment from ESD:

- Do not use mats designed to decrease electrostatic discharge as protection from electrical shock. Instead, use rubber mats that have been specifically designed as electrical insulators.
- Use a grounded wrist strap designed to prevent static discharge.
- Keep all components and printed circuit boards (PCBs) in their antistatic bags until ready for use.
- Touch a grounded metal object before removing any board from its antistatic bag.
- Do not let components or PCBs come into contact with your clothing, which may retain a charge even if you are wearing a wrist strap.
- Handle the backplane by its edges only; do not touch its components, peripheral chips, memory modules or contacts.
- When handling chips or modules, avoid touching their pins.
- Put the serverboard and peripherals back into their antistatic bags when not in use.

- For grounding purposes, make sure your computer chassis provides excellent conductivity between the power supply, the case, the mounting fasteners and the serverboard.

Chapter 3

Chassis Components

3-1 Overview

This chapter describes the most common components included with your chassis. Some components listed may not be included or compatible with your particular chassis model. For more information, see the installation instructions detailed later in this manual.

3-2 Components

Chassis

The SC818G chassis includes three 3.5" hard drive bays and options for peripheral drives. For the latest options, visit our Web site at: <http://www.supermicro.com>.

This chassis accepts a 1U backplane, up to eight fans and a power supply. SC818G models come in black.

Backplane

Each SC818G chassis comes with a 1U backplane. The backplane will accept SAS/SATA. For more information regarding compatible backplanes, view the appendices found at the end of this manual. In addition, visit our Web site for the latest information: <http://www.supermicro.com>.

Fans

The SC818G chassis accepts up to eight system fans. System fans for SC818G chassis are powered from the serverboard. These fans are 1U high and are powered by 4-pin connectors.

Rack Mounting

The SC818G can be placed in a rack for secure storage and use. To install the chassis in a rack, follow the step-by-step instructions included in this manual.

Power Supply

Each SC818G chassis model includes a high-efficiency power supply rated at 1400 Watts. In the unlikely event the power supply fails, replacement is simple and can be done without tools.

Air Shroud

Air shrouds are funnel air directly to where it is needed. Always use the air shroud included with your chassis.

3-3 Where to get Replacement Components

Though not frequently, you may need replacement parts for your system. To ensure the highest level of professional service and technical support, we strongly recommend purchasing exclusively from our Supermicro Authorized Distributors / System Integrators / Resellers. A list of Supermicro Authorized Distributors / System Integrators / Reseller can be found at: <http://www.supermicro.com>. Click the Where to Buy link.

Chapter 4

System Interface

4-1 Overview

There are several LEDs on the control panel and on the drive carriers that provide system and component status. This chapter explains the meanings of the LED indicators and the appropriate responses that need to be taken.



Figure 4-1: Control Panel Buttons and LEDs

4-2 Control Panel Buttons

The SC818G chassis includes two or three push-buttons located on the front panel: a reset button and a power on/off button.

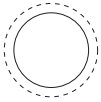

- **Reset:** The reset button is used to reboot the system.



- **Power:** The main power switch is used to apply or remove power from the power supply to the server system. Turning off system power with this button removes the main power but keeps standby power supplied to the system. Therefore, you must unplug system before servicing.

4-3 Control Panel LEDs

The control panel located on the front of the SC818G chassis has five LEDs. These LEDs provide critical information related to different parts of the system. This section explains what each LED indicates when illuminated and any action that may be required.



- **Universal Information LED:** The Universal Information LED is used to indicate fan failure, power failure, overheat condition, or to identify the unit within a large rack installation. The feature requires a motherboard that supports the Universal Information LED.

When this LED blinks red quickly, it indicates a fan failure and when blinking red slowly a power failure. This LED will be blue when used for UID (Unit Identifier). When on continuously red, it indicates an overheat condition, which may be caused by cables obstructing the airflow in the system or the ambient room temperature being too warm. See the table below for descriptions of the LED states.

Universal Information LED States	
State	Indication
Fast Blinking Red (1x/sec)	Fan Fail
Solid Red	CPU Overheat
Slow Blinking Red (1x/4 sec)	Power Fail
Solid Blue	Local UID Button Depressed
Blinking Blue	IPMI-Activated UID

Note: Deactivating the UID LED must be performed in the same way it was activated. (If the UID LED was activated via IPMI, you can only turn the LED off via IPMI and not with the UID button.)



- NIC2: Indicates network activity on GLAN2 when flashing.



- NIC1: Indicates network activity on GLAN1 when flashing.



- HDD: Indicates IDE channel activity, SAS/SATA drive, and/or peripheral drive activity when flashing.



- Power: Indicates power is being supplied to the system's power supply units. This LED should normally be illuminated when the system is operating.

4-4 Drive Carrier LEDs

Your chassis uses SAS/SATA drives.

SAS/SATA Drives

Each SAS/SATA drive carrier has two LEDs.

- **Green:** Each Serial ATA drive carrier has a green LED. When illuminated, this green LED (on the front of the SATA drive carrier) indicates drive activity. A connection to the SATA backplane enables this LED to blink on and off when that particular drive is being accessed.
- **Red:** The red LED to indicate an SAS/SATA drive failure. If one of the SAS/SATA drives fail, you should be notified by your system management software.

4-5 Overheating

Overheat Temperature Setting

Some backplanes allow the overheat temperature to be set at 45°, 50°, or 55° by changing a jumper setting. For more information, see the appendices at the back of this manual or download the backplane user guide at www.supermicro.com.

Overheating Condition

If the Server Overheats, do the Following:

1. Determine the nature of the overheating condition as described in the Control Panel LEDs section of this manual.
2. Confirm that the chassis covers are installed properly.
3. Check the routing of the cables and make sure all fans are present and operating normally.
4. Verify that the heatsinks are installed properly.

Notes

Chapter 5

Chassis Setup and Maintenance

5-1 Overview

This chapter covers the steps required to install components and perform maintenance on the chassis. The only tool you will need to install components and perform maintenance is a Phillips screwdriver. Print this page to use as a reference while setting up your chassis.

5-2 Installation Procedures

Removing the Chassis Cover

Removing and Installing Hard Drives

Peripheral Drive Installation

Installing the Motherboard (Includes standoff and riser card setup)

Installing the Air Shroud (Includes checking the airflow)

Procedures for Twin Motherboard Chassis

When utilizing twin motherboards, installation procedures differ and require specialized parts for the air shroud and riser card bracket. These specialized parts are sold separately and can be found on the Supermicro Web site at <http://www.supermicro.com>. This manual covers both standard and specialized part installation procedures.

General Maintenance

General Maintenance: Systems Fans

General Maintenance: Power Supply Replacement



Review the warnings and precautions listed in the manual before setting up or servicing this chassis. These include information in Chapter 2: System Safety and the warning/precautions listed in the setup instructions.

5-3 Removing the Chassis Cover

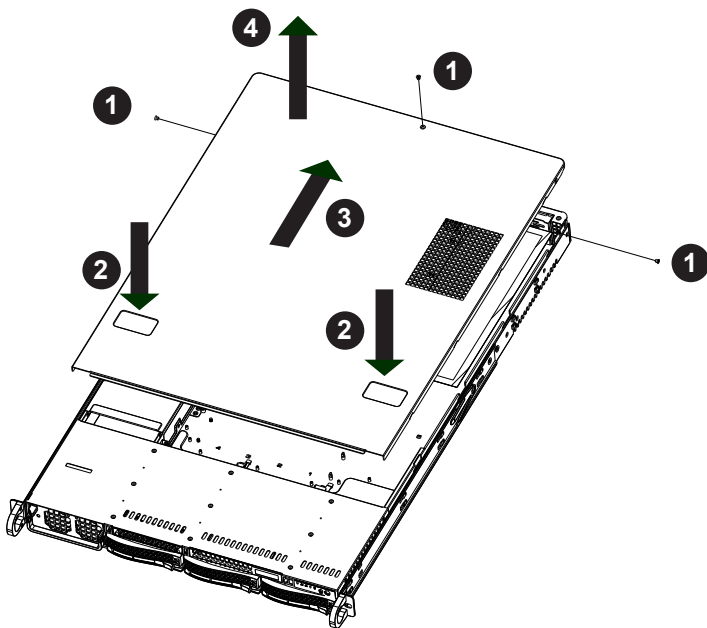

Figure 5-1: Removing the Chassis Cover

Removing the Chassis Cover:

1. Remove the three screws securing the top cover to the chassis.
2. Press both of the release tabs at the same time to release the cover
3. Slide the cover toward the rear of the chassis.
4. Lift the cover up and off of the chassis.



Warning: Except for short periods of time, do NOT operate the chassis without the cover in place. The chassis cover must be in place to allow proper airflow and prevent overheating.

5-4 Removing and Installing Hard Drives

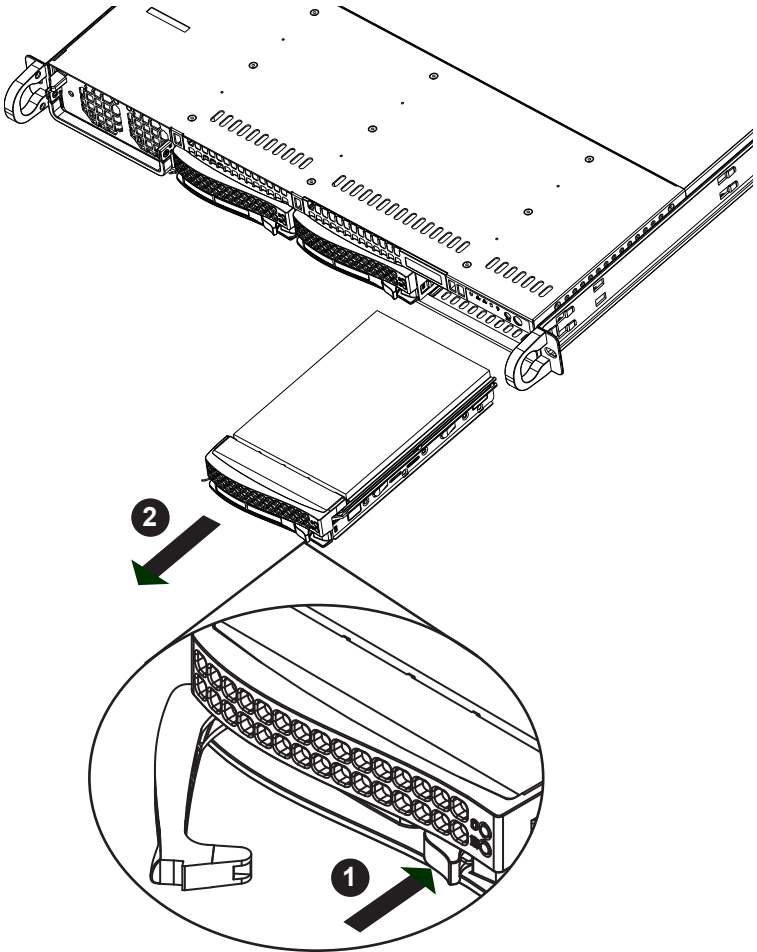

Figure 5-2: Removing Hard Drive

Removing Hard Drive Carriers from the Chassis

1. Press the release button on the drive carrier. This extends the drive carrier handle.
2. Use the handle to pull the drive carrier out of the chassis.

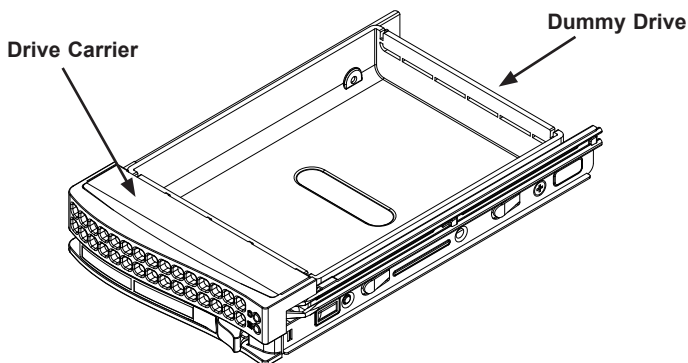

Figure 5-3: Hard Drive Carrier

The drives are mounted in drive carriers to simplify their installation and removal from the chassis. These carriers also help promote proper airflow for the drive bays.



Warning: Except for short periods of time (swapping hard drives), do not operate the server with the hard drives empty.

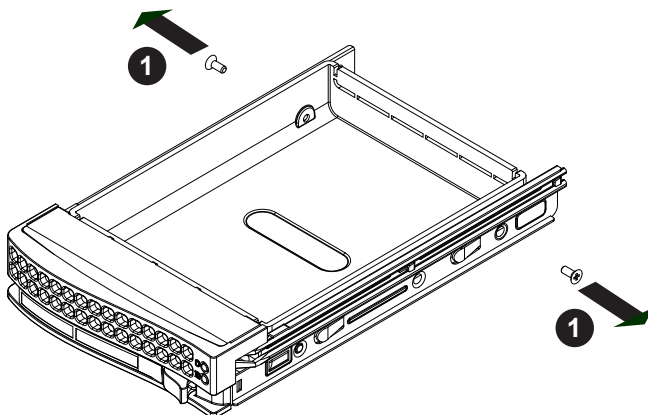

Figure 5-4: Removing Dummy Drive from Carrier

Installing a Hard Drive to the Hard Drive Carrier

1. Remove the two screws securing the dummy drive to the carrier.
2. Remove the dummy drive from the carrier.

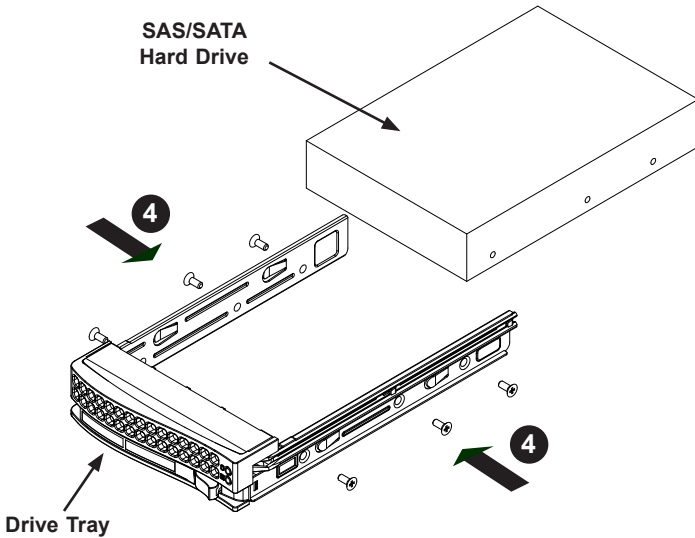

Figure 5-5: Removing Hard Drive

3. Install a new drive into the carrier with the printed circuit board side facing downward so that the mounting holes align with those in the carrier.
4. Secure the hard drive by tightening all six screws.

Installing a Hard Drive Carrier Into the Chassis

1. Insert the loaded hard drive carrier into the drive bay of the chassis
2. Push the drive carrier into the drive bay, pushing in the handle of the drive carrier until it clicks into the locked position.

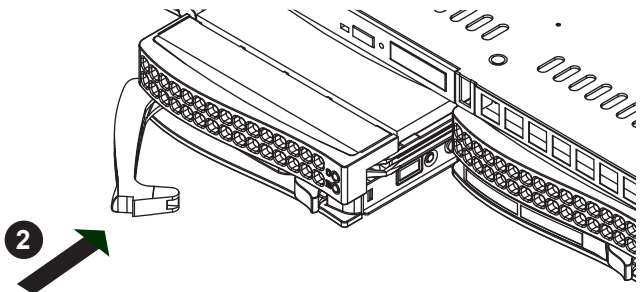

Figure 5-6: Installing the Hard Drive Carrier

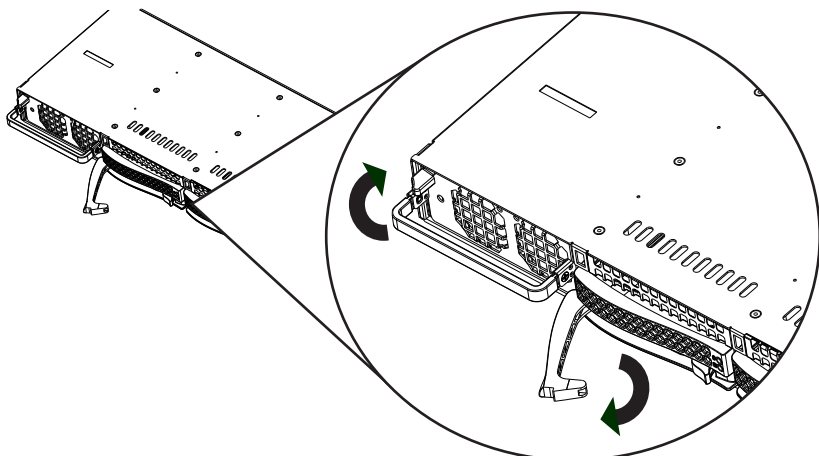

Figure 5-7: Installing/Removing the Hard Drive Carrier Next to the Power Supply

Note: When installing the hard drive carrier which is next to the power supply, that the power supply handle must be lifted before extending the hard drive carrier handle, or inserting the hard drive carrier into the drive bay.

5-5 Peripheral Drive Installation

The SC818G chassis includes space for a variety of peripheral drive options, including a 2.5" hard disk drive, DVD-ROM or floppy drive. For a complete listing of peripheral drive options, visit the Supermicro Web site at:

<http://www.supermicro.com/products/chassis/1U/818/SC818G-1400.cfm>

Installing or Replacing a Peripheral Drive

1. Unplug the main power cord to the chassis.
2. Unplug the power and data cables from the motherboard and/or backplane.
3. If you are adding a new drive: Remove the dummy tray from the drive bay. The mini-bezel can be removed by pulling out the hard drive beneath the drive bay, then pulling the mini-bezel forward.
If you are replacing a drive: Locate the locking tab at the rear (left hand side when viewed from the front) of the peripheral drive. Push the tab toward the drive and push the drive unit out the front of the chassis.
4. Re-use the side rails or install the side rails onto the peripheral drive
5. Insert the new drive unit in the slot until the tab locks in place.
6. Reconnect the data and power cables.
7. Replace the chassis cover (replace the server in the rack, if necessary) and power up the system.

5-6 Installing the Motherboard

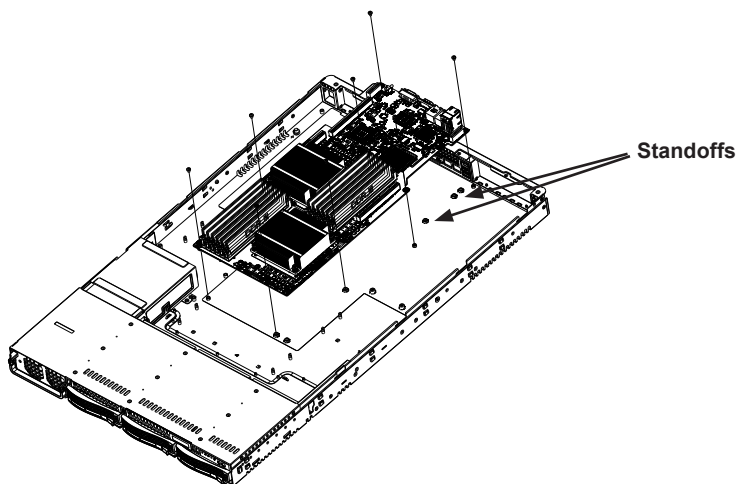

Figure 5-8: Chassis Standoffs

Permanent and Optional Standoffs

Standoffs prevent short circuits by securing space between the motherboard and the chassis surface. The SC818G chassis includes permanent standoffs in locations used by most motherboards. These standoffs accept the rounded Phillips head screws included in the SC818G accessories packaging.

Some motherboard require additional screws for heatsinks, general components and/or non-standard security. Optional standoffs are included to these motherboards. To use an optional standoff, you must place the hexagonal screw through the bottom of the chassis and secure the screw with the hexagon nut (rounded side up).

Motherboard Installation

Installing the Motherboard

1. Review the documentation that came with your motherboard. Become familiar with component placement, requirements, and precautions.
2. Disconnect the power supply and lay the chassis on a flat surface.
3. As required by your motherboard, install standoffs in any areas that do not have a permanent standoff. To do this:
 - A. Place a hexagonal standoff screw through the bottom the chassis.
 - B. Secure the screw with the hexagon nut (rounded side up).
4. Lay the motherboard on the chassis aligning the permanent and optional standoffs
5. Secure the motherboard to the chassis using the rounded, Phillips head screws. Do not exceed eight pounds of torque when tightening down the motherboard.
6. Secure the CPU(s), heatsinks, and other components to the motherboard, chassis, and/or backplane as needed.

Note: Both the top cover and the floor of the chassis are designed with an optional air ventilation grating, should additional air intake be required. To utilize the air grating, Peel back the mylar film covering the grating on the top cover, and or the floor of the chassis.

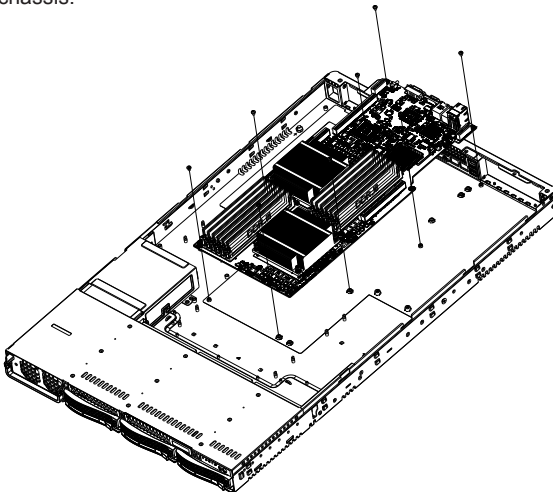

Figure 5-9: Installing the Motherboard

Expansion Card Setup

SC818G chassis includes I/O slots for add-on/expansion cards. The chassis includes four full-height/full length expansion slots and one low-profile expansion slot. The SC818G may also be configured for two optional double-width, high-end graphics cards, in the area shown below.

Note: You must use a riser card to install add-on cards in the SC818G chassis. Riser cards are sold separately.

Note: When installing twin motherboards, the MCP-240-81805-0N riser card bracket must be used instead of the standard riser card bracket. See page 5-13 of this manual or the Supermicro Web site at <http://www.supermicro.com> for details.

For the latest compatibility and performance information visit our website at: <http://www.supermicro.com>.

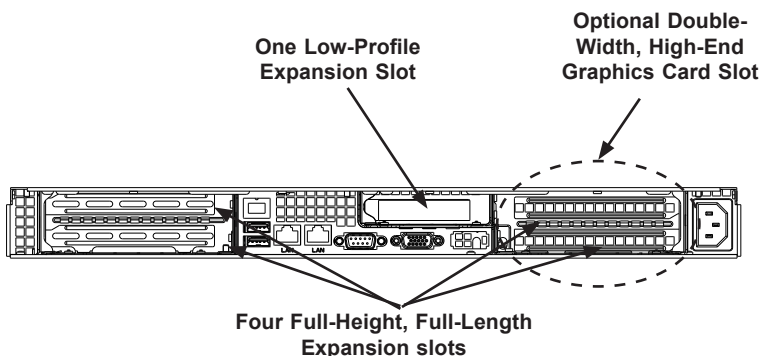

Figure 5-10: Rear Expansion Slots

The versatile SC818G chassis may be configured for a variety of applications. If chassis is to be configured with the X8DTG-DF motherboard, it is necessary to purchase a second add-on card, riser card and riser card bracket assembly. Use the chart below to determine the desired configuration option.

Note: Installing the optional graphics card configuration shown above, especially with twin motherboards, will require the I/O plate to be modified by cutting off any portion of the plate that may extend over the I/O panel components beside it. A special bracket is available for use with the graphics card that is shorter than the regular dummy bracket.

Left Riser	Low Profile Riser	Right Riser
RSC-R1UG-E16 (For double-width GPU cards)	RSC-R1UG-UR (For Supermicro LP UIO cards)	RSC-R1UG-E16R (For double-width GPU cards)

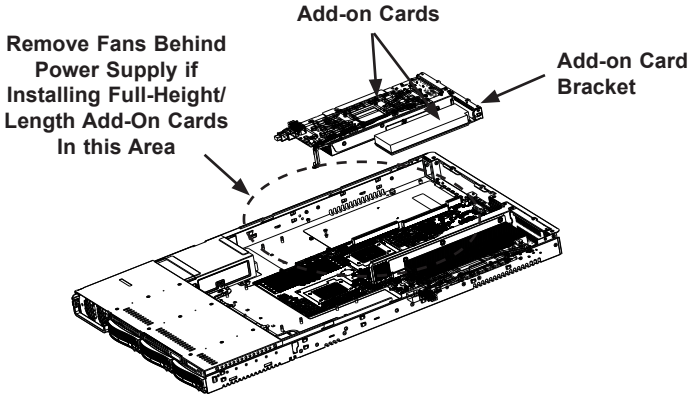

Figure 5-11: Installing Add-on Cards

Left Riser	Low Profile Riser	Right Riser
RSC-R-UG-2E8G (For two x8 cards)	RSC-R1U-E16R (For regular LP cards)	RSC-R1UG-2E8GR (For two x8 cards)

Installing an Add-on Card

1. Confirm that you have the correct add-on card, riser card and add-on card bracket for the SC818G chassis

Note: If installing full-height, full-length add-on cards in the area illustrated above, it is necessary to remove the set of fans behind the power supply. An optional 4028 fan module is available on the Supermicro Web site at www.supermicro.com.

Note: When installing twin motherboards, the MCP-240-81805-0N riser card bracket must be used instead of the standard riser card bracket. See page 5-13 of this manual or the Supermicro Web site at <http://www.supermicro.com> for details.

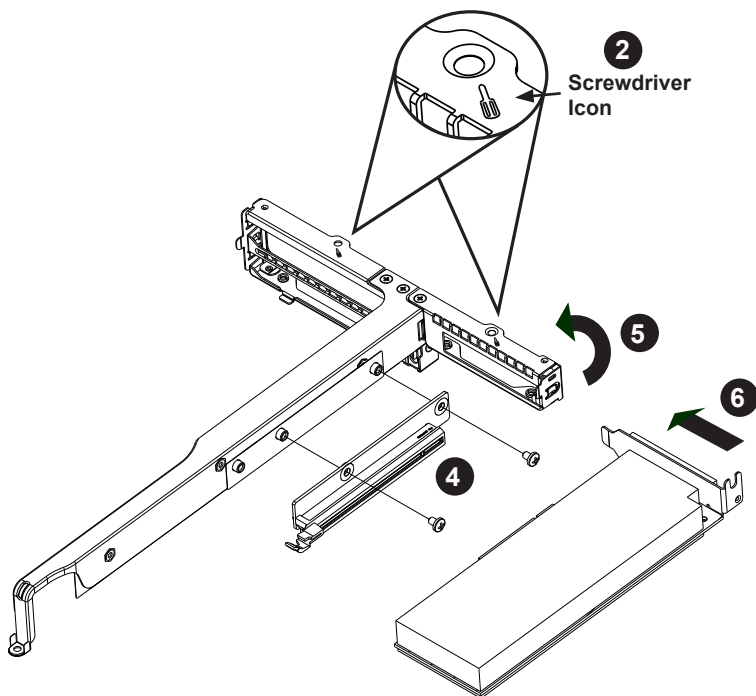

Figure 5-12: Installing the Riser and Add-on Cards in the Bracket

2. Remove the add-on card bracket from the chassis by unscrewing only those screws indicated by the screwdriver icon as illustrated on the following page.
3. Lift the add-on card bracket from the chassis.
4. Install the riser card on the bracket using the two screws provided.
5. Open the latch on the end of the bracket.
6. Install the add-on card by sliding the card into the appropriate slot in the riser card and close the bracket latch over the end of it.
7. Install the entire assembly into the appropriate slot on the motherboard.

Riser Card Bracket Installation with Twin Motherboards

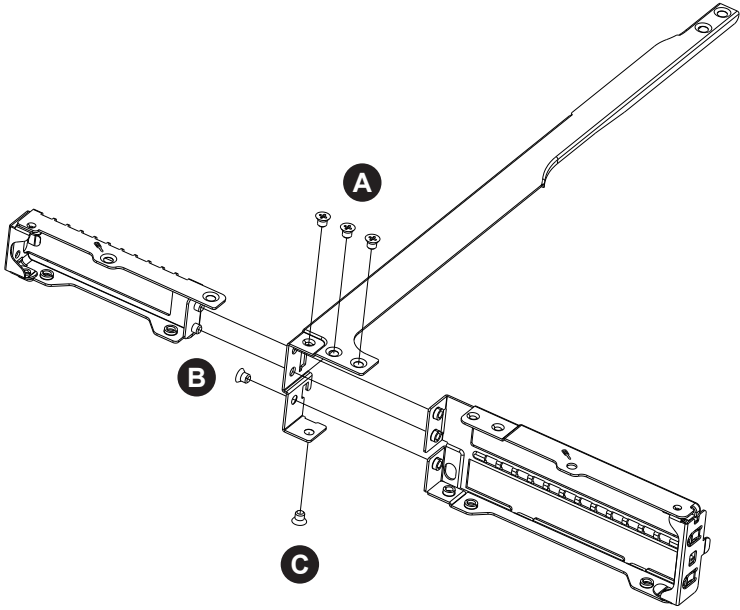

Figure 5-13: Riser Card Bracket Used with Twin Motherboards

When using twin motherboards, the MCP-240-81805-0N riser card bracket is required. This riser card bracket is sold separately. Visit <http://www.supermicro.com> for details.

Assembling the Riser Card Bracket for Twin Motherboards

1. Replace the original riser card bracket by taking the three brackets apart and re-using the left and right brackets.
2. Insert the left and right brackets into the tail bracket (MCP-240-81805-0N) and secure with the three top screws (A).
3. Secure the side screw (B)
4. Install the motherboard standoffs, along with the MCP-240-81805-0n as required on the motherboard.
5. Secure the bottom screw (C).
6. Install the riser card bracket as described in the previous section.

5-7 Installing the Air Shroud

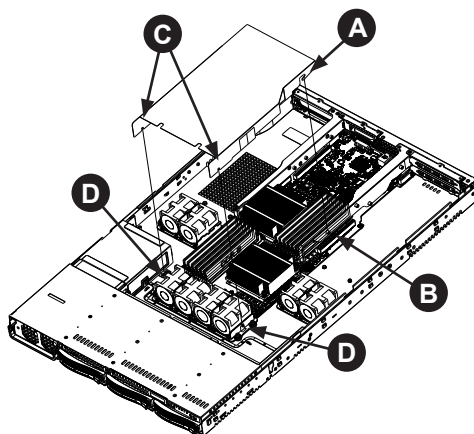

Figure 5-14: Air Shroud

Air shrouds concentrate airflow to maximize fan efficiency. The SC818G chassis air shroud does not require screws to set up.

Note: When installing twin motherboards, the MCP-310-81803-0B air shroud must be used. This air shroud is sold separately. Information is available on the Supermicro Web site at <http://www.supermicro.com>. Installation of the MCP-310-81803-0B air shroud is identical to the installation of a standard air shroud, which is described below.

Installing the Air Shroud

1. Position the air shroud in the chassis as illustrated above.
2. Align the notch (A) on the air shroud with the pin (B) on the add-on card bracket.
3. Slide the pin (B) into the back of the notch (A)
4. Lower the front of the air shroud over the fan tray, sliding the front notches (C) over the pins on the fan tray (D).

Checking the Air Flow

Checking the Air Flow in the Chassis

1. Make sure there are no wires or other objects obstructing the airflow in and out of the server. Pull all excess cabling out of the airflow path or use shorter cables.
2. Do not operate the server without drives or drive trays in the drive bays. Use only recommended server parts.
3. The control panel LEDs inform you of the overall system status. See “Chapter 3 System Interface” for details on the LEDs and the control panel buttons.

5-8 System Fans



Figure 5-15: System Fan

Eight heavy-duty fans provide cooling for the chassis. These fans circulate air through the chassis as a means of lowering the chassis' internal temperature.

The chassis includes counter-rotating fans. Each fan unit is actually made up of two fans joined back-to-back, which rotate in opposite directions. This counter-rotating action generates exceptional airflow and works to dampen vibration levels.

Fan Numbering in the BIOS

In the unlikely event of a fan failure, the failed system fan can be identified through the BIOS, by utilizing the fan numbering system shown below. These numbers are also imprinted on the floor of the chassis.

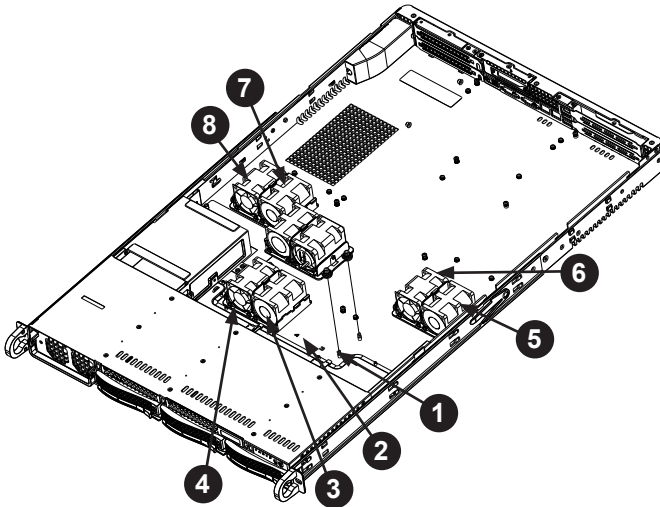

Figure 5-16: Fan BIOS Numbering

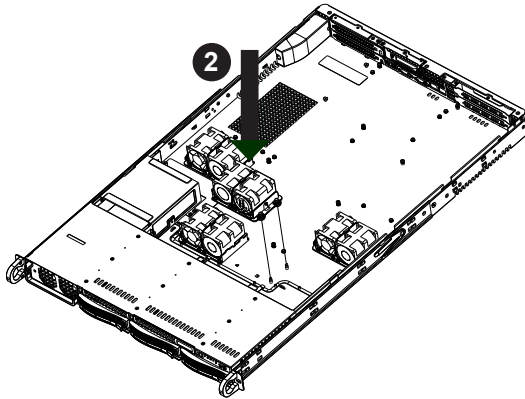

Figure 5-17: Adding a System Fan Tray

Maintaining System Fan Trays

Some SC818G chassis may be configured with extra space to provide room for an optional additional fan tray, should additional cooling be required.

Adding an Additional System Fan Tray

1. Turn off the power to the system and unplug the system from the outlet.
2. Place the additional fan tray into the vacant space in the the chassis, aligning the mounting holes in the fan tray with the mounting holes in the floor of the chassis and aligning the fan tray so that it is facing in the the *opposite direction* from the fan beside it. These trays hook together and must be connected in alternating directions in order to fit within the chassis.
3. Connect the fan wires to the fan headers.
4. Power up the system and check that the fan is working properly before replacing the chassis cover.

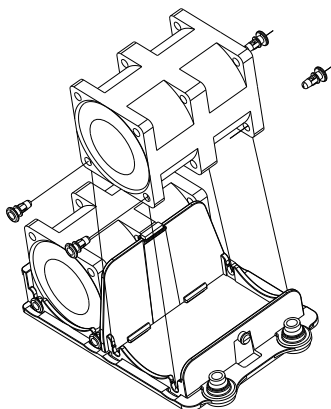

Figure 5-18: Removing a System Fan from the Fan Tray

Replacing a System Fan

1. If the BIOS is not being utilized to determine which fan has failed, open the top cover of the chassis while the system is running to locate the position of the failed fan. Never run the server for an extended period of time with the top cover open.
2. Turn off the power to the system and unplug the system from the outlet.
3. Remove the failed fan's power cord from the backplane.
4. Remove the four pins securing the fan to the fan tray.
5. Lift the failed fan from the fan tray and out of the chassis.
6. Place the new fan into the vacant space in the fan tray, while making sure the arrows on the top of the fan (indicating air direction) point in the same direction as the arrows on the other fans in the same fan tray.
7. Reconnect the fan wires to the exact same chassis fan headers as the previous fan.
8. Power up the system and check that the fan is working properly before replacing the chassis cover.

5-9 Power Supply

The SC818G chassis includes a 1400 Watt power supply. This power supply is auto-switching capable. The power supply automatically sense and operates at a 100v to 240v input voltage.

Power Supply Replacement

If the power supply unit fails, the system will shut down and you will need to replace the unit. Replacement units can be ordered directly from Supermicro (see contact information in the Preface). As there is only one power supply unit in the SC818G chassis, power must be completely removed from the server before removing and replacing the power supply unit.

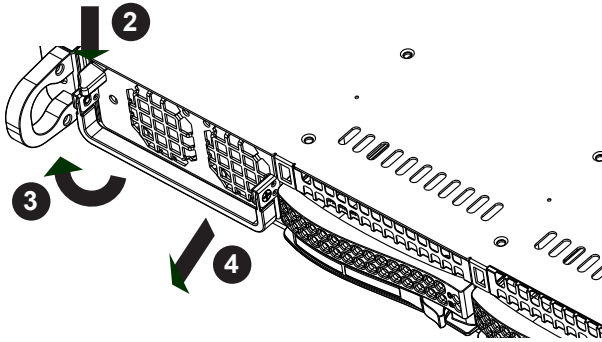

Figure 5-19: Removing the Power Supply

Replacing the Power Supply

1. Power down the server and unplug the power cord.
2. Push the release tab on the front of the power supply.
3. Lift the handle of the power supply.
4. Pull the power supply out of the power supply bay.
5. Push the new power supply module into the power bay until it clicks into the locked position.
6. Plug the AC power cord back into the module and power up the server.

Notes

Chapter 6

Rack Installation

6-1 Overview

This chapter provides a quick setup checklist to get your chassis up and running. Following these steps in the order given should enable you to have the system operational within a minimum amount of time.

6-2 Unpacking the System

You should inspect the box the chassis was shipped in and note if it was damaged in any way. If the chassis itself shows damage you should file a damage claim with the carrier who delivered it.

Decide on a suitable location for the rack unit that will hold your chassis. It should be situated in a clean, dust-free area that is well ventilated. Avoid areas where heat, electrical noise and electromagnetic fields are generated. You will also need it placed near a grounded power outlet. Be sure to read the Rack and Server Precautions in the next section.

6-3 Preparing for Setup

The box your chassis was shipped in should include two sets of rail assemblies, two rail mounting brackets and the mounting screws you will need to install the system into the rack. Please read this section in its entirety before you begin the installation procedure outlined in the sections that follow.

Choosing a Setup Location

- Leave enough clearance in front of the rack to enable you to open the front door completely (~25 inches).
- Leave approximately 30 inches of clearance in the back of the rack to allow for sufficient airflow and ease in servicing.
- This product is for installation only in a Restricted Access Location (dedicated equipment rooms, service closets and the like).



Warnings and Precautions!



Rack Precautions

- Ensure that the leveling jacks on the bottom of the rack are fully extended to the floor with the full weight of the rack resting on them.
- In single rack installation, stabilizers should be attached to the rack.
- In multiple rack installations, the racks should be coupled together.
- Always make sure the rack is stable before extending a component from the rack.
- You should extend only one component at a time - extending two or more simultaneously may cause the rack to become unstable.

General Server Precautions

- Review the electrical and general safety precautions that came with the components you are adding to your chassis.
- Determine the placement of each component in the rack *before* you install the rails.
- Install the heaviest server components on the bottom of the rack first, and then work up.
- Use a regulating uninterruptible power supply (UPS) to protect the server from power surges, voltage spikes and to keep your system operating in case of a power failure.
- Allow the hot plug hard drives and power supply modules to cool before touching them.
- Always keep the rack's front door and all panels and components on the servers closed when not servicing to maintain proper cooling.

Rack Mounting Considerations

Ambient Operating Temperature

If installed in a closed or multi-unit rack assembly, the ambient operating temperature of the rack environment may be greater than the ambient temperature of the room. Therefore, consideration should be given to installing the equipment in an environment compatible with the manufacturer's maximum rated ambient temperature (TMRA).

Reduced Airflow

Equipment should be mounted into a rack so that the amount of airflow required for safe operation is not compromised.

Mechanical Loading

Equipment should be mounted into a rack so that a hazardous condition does not arise due to uneven mechanical loading.

Circuit Overloading

Consideration should be given to the connection of the equipment to the power supply circuitry and the effect that any possible overloading of circuits might have on overcurrent protection and power supply wiring. Appropriate consideration of equipment nameplate ratings should be used when addressing this concern.

Reliable Ground

A reliable ground must be maintained at all times. To ensure this, the rack itself should be grounded. Particular attention should be given to power supply connections other than the direct connections to the branch circuit (i.e. the use of power strips, etc.).

6-4 Rack Mounting Instructions

This section provides information on installing the SC818G chassis into a rack unit with the quick-release rails provided. There are a variety of rack units on the market, which may mean that the assembly procedure will differ slightly. You should also refer to the installation instructions that came with the rack unit you are using.

NOTE: This rail will fit a rack between 26" and 33.5" deep.

Identifying the Sections of the Rack Rails

The chassis package includes two quick-release rail assemblies in the rack mounting kit. Each assembly consists of two primary sections: an inner fixed chassis rail and inner rail extension that secure directly to the chassis, and an outer rail assembly that secures directly to the rack itself.

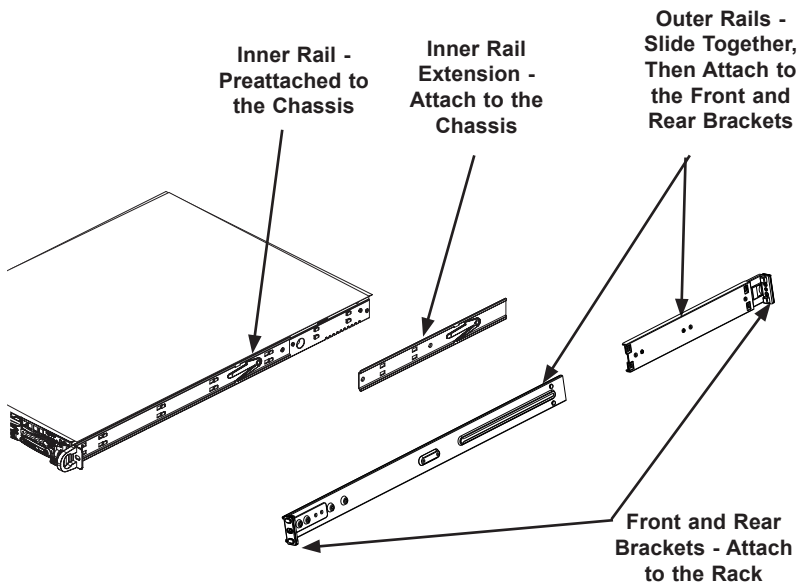

Figure 6-1: Identifying the Sections of the Inner and Outer Rack Rails (right side rack rail shown)

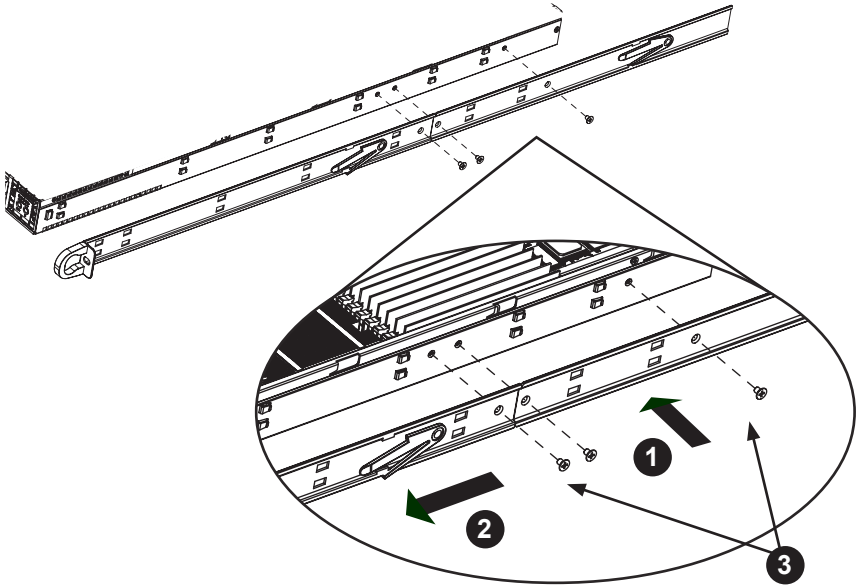

Figure 6-2: Installing the Inner Rails

Installing the Inner Rail Extensions

The SC818G chassis includes a set of inner rails in two sections: inner rails (A) and inner rail extensions (B), which are attached to the chassis. The inner rails are preattached and do not interfere with normal use of the chassis if you decide not to use a server rack. Attach the inner rail extensions stabilize the chassis within the rack.

Installing the Inner Rail Extensions

1. Place the inner rail extensions (B) over the preattached inner rails (A) which are attached to the side of the chassis. Align the hooks of the inner rail with the rail extension holes. Make sure the extension faces "outward" just like the inner rail.
2. Slide the extension toward the front of the chassis.
3. Secure the chassis with screws as illustrated.
4. Repeat steps 1-3 for the other inner rail extension.

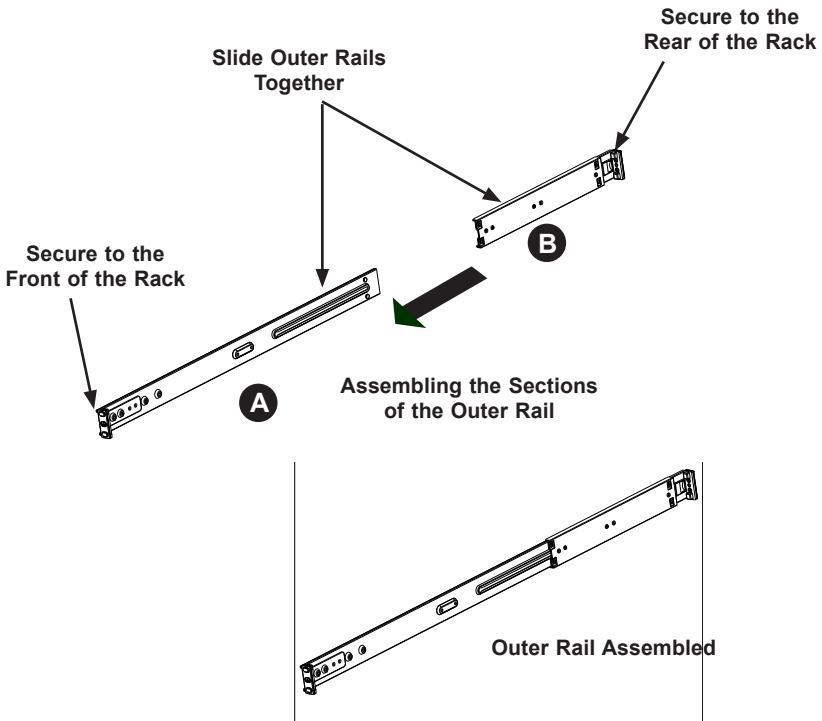

Figure 6-3: Assembling the Outer Rails

Assembling the Outer Rails

Each outer rail is in two sections that must be assembled before mounting onto the rack.

Assembling the Outer Rails

1. Identify the left and right outer rails by examining the ends, which bend outward.
2. Slide the front section of the outer rail (A), into the rear section of the outer rail (B).

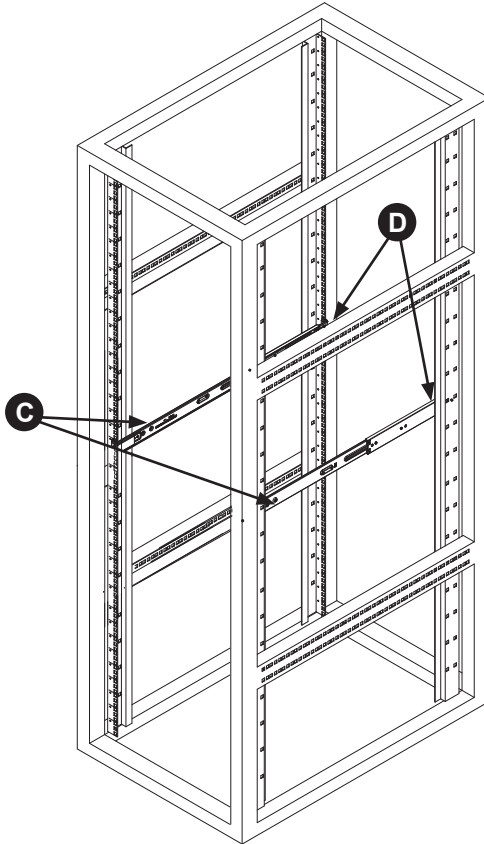

Figure 6-4: Installing the Outer Rails to the Rack

Installing the Outer Rails onto the Rack

Outer Rail Installation

1. Adjust the outer rails to the proper length so that the outer rail fits snugly within the rack.
2. Align the holes on the front of the outer rail, with the holes on the front of the rack (C) and secure with the screws provided.
3. Align the holes on the rear of the outer rail to the holes on the rack (D) and secure with the screws provided.
4. Repeat the procedure with the second outer rail assembly.



Figure 6-5: Chassis Installation Figure 6-6: Removing the Chassis

Installing and Removing the Chassis From the Rack

Installation into the Rack

1. Slide the inner rail extensions into the front of the outer rails.
2. Push the chassis backward into the rack until it clicks into the locked position.

Removing the Chassis From the Rack

1. Press the outer rail latch to release the chassis.
2. Carefully slide the chassis forward, off the outer rails and out of the chassis.

6-5 Installing the Server into a Telco Rack

To install the chassis into a Telco (post) type rack, use two L-shaped brackets (Optional with the MCP-290-00016-0N) on either side of the chassis (four total). First, determine how far forward the chassis will extend out the front of the rack. Larger chassis should be positioned to balance the weight between front and back. If a bezel is included on your chassis, remove it. Then attach the two front brackets to each side of the chassis, then the two rear brackets positioned with just enough space to accommodate the width of the Telco rack. Finish by sliding the chassis into the rack and tightening the brackets to the rack.

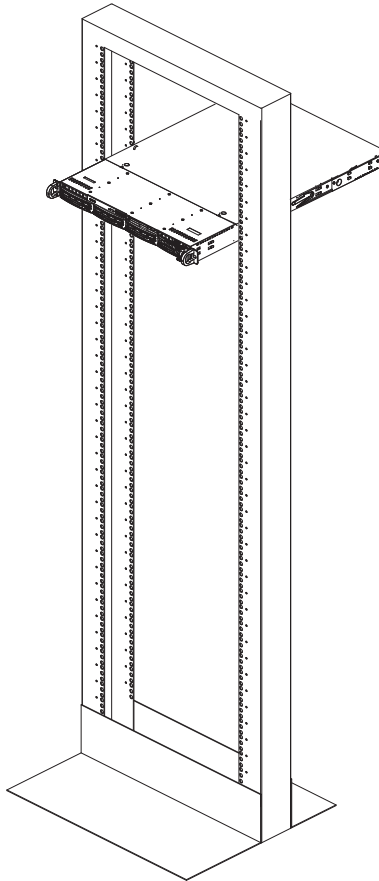

Figure 6-7: Chassis Installed in a Telco (Post-Style) Rack

Notes

Appendix A

SC818G Chassis Cables and Accessories

A-1 Overview

This appendix lists supported cables for your chassis system. It only includes the most commonly used components and configurations. For more compatible cables, refer to the manufacturer of the motherboard you are using and our Web site at: www.supermicro.com.

A-2 Cables Included with SC818GTQ (SAS/SATA)

SC818G-1400B			
Part #	Type	Length	Description
CBL-0154L	Cable	---	AC Power Cable.
CBL-0087	Ribbon, round cable	20"	16 pin to 16 pin ribbon cable for control panel

A-3 Compatible Cables

These cables are compatible with the SC818G Chassis.

Alternate SAS/SATA Cables

Some compatible motherboards have different connectors. If your motherboard has only one SAS connector that the SAS/SATA cables must share, use one of the following cables. These cables must be purchased separately.

Cable Name: SAS Cable

Quantity: 1

Part #: CBL-0175L

Alt. Name: "Big Four"

Description: This cable has one SFF-8484 (32 pin) connector on one end and 4 SAS connectors (7 pins each) at the other. This cable connects from the Host (motherboard or other controller) to the backplane SAS hard drive port.

Cable Name: SAS Cable**Quantity:** 1**Part #:** CBL-0116**Alt. Name:** iPass or "Small Four"

Description: This cable has one ipass (SFF-8087/mini-sas) connector (36 pins) at one end and 4 SAS connectors on one end. This cable connects from the Host (motherboard or other controller) to the backplane SAS hard drive port.

Extending Power Cables

Although Super Micro chassis are designed with to be efficient and cost-effective, some compatible motherboards have power connectors located in different areas.

To use these motherboards you may have to extend the power cables to the motherboards. To do this, use the following chart as a guide.

Power Cable Extenders		
Number of Pins	Cable Part #	Length
24 pin	CBL - 0042	7.9"(20 CM)
20 pin	CBL - 0059	7.9"(20 CM)
8 pin	CBL - 0062	7.9"(20 CM)
4 pin	CBL - 0060	7.9"(20 CM)

Front Panel to the Motherboard

The SC818G chassis includes a cable to connect the chassis front panel to the motherboard. If your motherboard uses a different connector, use the following list to find a compatible cable.

Front Panel to Motherboard Cable (Ribbon Cable)		
Number of Pins (Front Panel)	Number of Pins (Motherboard)	Cable Part #
16 pin	16 pin	CBL - 0049
16 pin	20 pin	CBL - 0048
20 pin	20 pin	CBL - 0047
16 pin	Split*	CBL - 0068
20 pin	Split*	CBL - 0067

* Split cables: Use these cables if your motherboard has different pin definitions than a Supmicro motherboard.

A-4 Chassis Screws

The accessory box includes all the screws needed to setup your chassis. This section lists and describes the most common screws used. Your chassis may not require all the parts listed.

M/B



Pan head
6-32 x 5 mm
[0.197]

HARD DRIVE



Flat head
6-32 x 5 mm
[0.197]

DVD-ROM, CD-ROM, and FLOPPY DRIVE



Pan head
6-32 x 5 mm
[0.197]



Flat head
6-32 x 5 mm
[0.197]



Round head
M3 x 5 mm
[0.197]



Round head
M2.6 x 5 mm
[0.197]

RAIL



Flat head
M4 x 4 mm
[0.157]



Round head
M4 x 4 mm
[0.157]



Flat head
M5 x 12 mm [0.472]
Washer for M5



M/B STANDOFFS



M/B standoff
6-32 to 6-32



M/B (CPU)
standoff
M5 to 6-32



Thumb screw
6-32 x 5 mm
[0.197]



1/2 M/B standoff
6-32 x 5 mm
[0.197]



Notes

Appendix B

SC818G Power Supply Specifications

This appendix lists power supply specifications for your chassis system.

SC818G-1400B	
1400W	
MFR Part #	PWS-1K41F-1R
AC Input	1200W: 100-140V, 50-60 Hz, 10.5-14.7 Amp 1400W: 180 - 240v, 50 - 50hZ, 7.2 - 9.5 Amp
DC Output +5V standby	6 Amp
DC Output +12V	100 Amp @ 100 - 140V 117 Amp @ 180

Notes

Appendix C

SAS-818TQ Backplane Specifications

To avoid personal injury and property damage, carefully follow all the safety steps listed below when accessing your system or handling the components.

C-1 ESD Safety Guidelines

Electrostatic Discharge (ESD) can damage electronic components. To prevent damage to your system, it is important to handle it very carefully. The following measures are generally sufficient to protect your equipment from ESD.

- Use a grounded wrist strap designed to prevent static discharge.
- Touch a grounded metal object before removing a component from the antistatic bag.
- Handle the RAID card by its edges only; do not touch its components, peripheral chips, memory modules or gold contacts.
- When handling chips or modules, avoid touching their pins.
- Put the card and peripherals back into their antistatic bags when not in use.

C-2 General Safety Guidelines

- Always disconnect power cables before installing or removing any components from the computer, including the backplane.
- Disconnect the power cable before installing or removing any cables from the backplane.
- Make sure that the backplane is securely and properly installed on the motherboard to prevent damage to the system due to power shortage.

C-3 An Important Note to Users

- All images and layouts shown in this user's guide are based upon the latest PCB Revision available at the time of publishing. The card you have received may or may not look exactly the same as the graphics shown in this manual.

C-4 Introduction to the SAS-818TQ Backplane

The SAS-818TQ backplane has been designed to utilize the most up-to-date technology available, providing your system with reliable, high-quality performance.

This manual reflects SAS-818TQ Revision 1.00, the most current release available at the time of publication. Always refer to the Supermicro Web site at www.supermicro.com for the latest updates, compatible parts and supported configurations.

Jumper Settings and Pin Definitions

C-5 Front Connectors and Jumpers

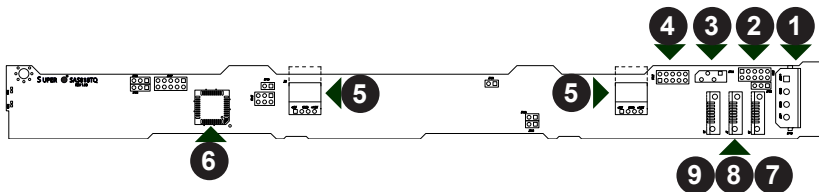

Figure C-1: Front View

Front Connectors

1. JP10: Backplane Main PWR (4-Pin)
2. JP51: Sideband Connector
3. JP44: I²C Connector
4. JP26: ACT IN
5. J9 and J10: CD-ROM/Floppy Drive (4-Pin) PWR Connector
6. AMI MG9071 Chip
7. J8: SAS/SATA Port #0
8. J7: SAS/SATA Port #1
9. J6: SAS/SATA Port #2

C-6 Front Connector and Pin Definitions

#1. Backplane Main Power Connector

The 4-pin connector, designated JP10, provides power to the backplane. See the table on the right for pin definitions.

Backplane Main Power 4-Pin Connector (JP10)	
Pin#	Definition
1	+12V
2 and 3	Ground
4	+5V

#2. Sideband Connector

The sideband connector is designated JP51. For SES-2 to work properly, you must connect an 10-pin sideband cable to JP51. See the table to the right for pin definitions.

Sideband Connector (JP51)			
Pin #	Definition	Pin #	Definition
2	Backplane Addressing (SB5)	1	Controller ID (SB6)
4	Reset (SB4)	3	GND (SB2)
6	GND (SB3)	5	SDA (SB1)
8	Backplane ID (SB7)	7	SCL (SB0)
10	No Connection	9	No Connection

#3. I²C Connector

The I²C Connector, designated JP44, is used to monitor HDD activity and status. See the table on the right for pin definitions.

I ² C Connector Pin Definitions (JP44)	
Pin#	Definition
1	Data
2	Ground
3	Clock
4	No Connection

#4. Activity LED Header

The activity LED header, designated JP26, is used to indicate the activity status of each hard drive. The Activity LED Header is located on the rear of the front panel. For the Activity LED Header to work properly, connect using a 10-pin LED cable.

SAS Activity LED Header Pin Definitions (JP26)			
Pin #	Definition	Pin #	Definition
1	ACT IN#0	6	ACT IN#4
2	ACT IN#1	7	ACT IN#5
3	ACT IN#2	8	ACT IN#6
4	ACT IN#3	9	ACT IN#7
5	Ground	10	Empty

#5. CD-ROM/Floppy 4-Pin Connectors

The 4-pin connectors, designated J9 and J10, provide power to the CD-ROM and floppy drives. See the table on the right for pin definitions.

CD-ROM/ FDD Power 4-Pin Connector (J9 and J10)	
Pin#	Definition
1	+12V
2 and 3	Ground
4	+5V

#6. MG9072 Chip

The MG9072 is an enclosure management chip used in the 818 TQ backplane.

#7 - #9. SAS/SATA Ports

The SAS ports are used to connect the SAS drive cables. The 3 ports are designated #0 - #2 and are compatible with SATA drives.

C-7 Front Jumper Locations and Pin Definitions

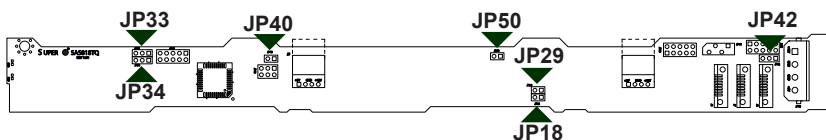
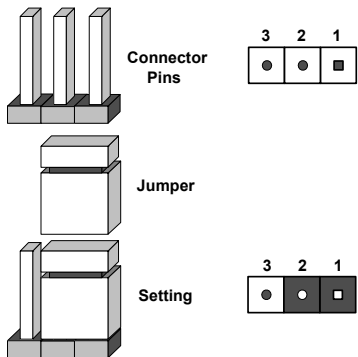

Figure C-2: Front View

Explanation of Jumpers

To modify the operation of the backplane, jumpers can be used to choose between optional settings. Jumpers create shorts between two pins to change the function of the connector. Pin 1 is identified with a square solder pad on the printed circuit board.



Note: On two pin jumpers, "Closed" means the jumper is on and "Open" means the jumper is off the pins.

Jumper Settings		
Jumper	Jumper Settings	Note
JP18	Open = Enabled (Default) Closed = Disabled	Buzzer reset*
JP29	Open = Default Closed = Chip Diagnostic	Chip reset

*The buzzer sound indicates that a condition requiring immediate attention has occurred.

The buzzer alarm is triggered by the following conditions:

1. Hard drive failure
2. Fan failure
3. System temperature over 45° Celsius.

I²C and SGPIO Modes and Jumper Settings

This backplane can utilize I²C or SGPIO. I²C is the default mode and can be used without making changes to your jumpers. The following information details which jumpers must be configured to use SGPIO mode or restore your backplane to I²C mode.

I ² C Mode (Default)		
Jumper	Jumper Setting	Note
JP33	2-3	Controller ID #1
JP34	1-2: ID#0 2-3: ID#1	Backplane ID #1
JP40	Open	I ² C Reset _SDOUT#1
JP42	2-3	I ² C Backplane ID _SDIN#1
JP50	Closed	I ² C Reset #1

SGPIO Mode Only		
Jumper	Jumper Setting	Note
JP33	1-2	Controller ID #1
JP34	1-2: ID#0 2-3: ID#1	Backplane ID #1
JP40	Closed	I ² C Reset _SDOUT#1
JP42	1-2	I ² C Backplane ID _SDIN#1
JP50	Open	I ² C Reset #1

Front LED Indicator

Front LED	
Jumper	Description
D4 (Front)	Overheat/Drive Failure LED Indicator (Red light: flashing, Buzzer: On)

C-8 Rear Connectors and LED Indicators

Rear Connector and LED Locations

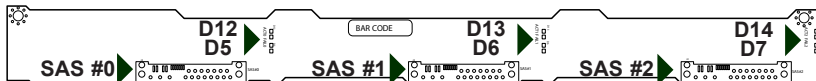

Rear LED Indicators

Rear SAS/SATA Connectors	
Rear Connector	SAS/SATA Drive Number
SAS#0	SAS/SATA HDD #0
SAS#1	SAS/SATA HDD #1
SAS#2	SAS/SATA HDD #2

Rear LED Indicators	
Rear LED Indicator	Hard Drive Activity and Failure LEDs
D12	SAS#0 Activity LED (Connected to HDD)
D13	SAS#1 Activity LED (Connected to HDD)
D14	SAS#2 Activity LED (Connected to HDD)
D5	SAS#0 Failure LED (Connected to HDD)
D6	SAS#1 Failure LED (Connected to HDD)
D7	SAS#2 Failure LED (Connected to HDD)

Notes

Disclaimer (cont.)

The products sold by Supermicro are not intended for and will not be used in life support systems, medical equipment, nuclear facilities or systems, aircraft, aircraft devices, aircraft/emergency communication devices or other critical systems whose failure to perform be reasonably expected to result in significant injury or loss of life or catastrophic property damage. Accordingly, Supermicro disclaims any and all liability, and should buyer use or sell such products for use in such ultra-hazardous applications, it does so entirely at its own risk. Furthermore, buyer agrees to fully indemnify, defend and hold Supermicro harmless for and against any and all claims, demands, actions, litigation, and proceedings of any kind arising out of or related to such ultra-hazardous use or sale.