

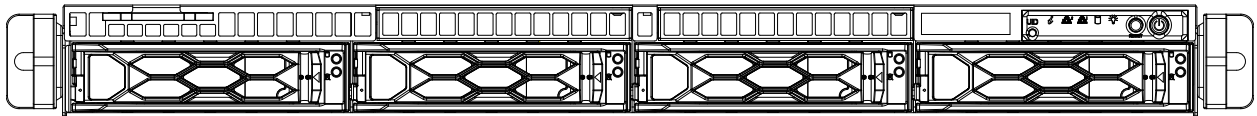

CSE-LA15-W



Cost-Effective Chassis Series
Single & Redundant Power

USER'S MANUAL

Revision 1.0

The information in this User's Manual has been carefully reviewed and is believed to be accurate. The vendor assumes no responsibility for any inaccuracies that may be contained in this document, and makes no commitment to update or to keep current the information in this manual, or to notify any person or organization of the updates. Please Note: For the most up-to-date version of this manual, please see our website at www.supermicro.com.

Super Micro Computer, Inc. ("Supermicro") reserves the right to make changes to the product described in this manual at any time and without notice. This product, including software and documentation, is the property of Supermicro and/or its licensors, and is supplied only under a license. Any use or reproduction of this product is not allowed, except as expressly permitted by the terms of said license.

IN NO EVENT WILL Super Micro Computer, Inc. BE LIABLE FOR DIRECT, INDIRECT, SPECIAL, INCIDENTAL, SPECULATIVE OR CONSEQUENTIAL DAMAGES ARISING FROM THE USE OR INABILITY TO USE THIS PRODUCT OR DOCUMENTATION, EVEN IF ADVISED OF THE POSSIBILITY OF SUCH DAMAGES. IN PARTICULAR, SUPER MICRO COMPUTER, INC. SHALL NOT HAVE LIABILITY FOR ANY HARDWARE, SOFTWARE, OR DATA STORED OR USED WITH THE PRODUCT, INCLUDING THE COSTS OF REPAIRING, REPLACING, INTEGRATING, INSTALLING OR RECOVERING SUCH HARDWARE, SOFTWARE, OR DATA.

Any disputes arising between manufacturer and customer shall be governed by the laws of Santa Clara County in the State of California, USA. The State of California, County of Santa Clara shall be the exclusive venue for the resolution of any such disputes. Supermicro's total liability for all claims will not exceed the price paid for the hardware product.

FCC Statement: This equipment has been tested and found to comply with the limits for a Class A digital device pursuant to Part 15 of the FCC Rules. These limits are designed to provide reasonable protection against harmful interference when the equipment is operated in a commercial environment. This equipment generates, uses, and can radiate radio frequency energy and, if not installed and used in accordance with the manufacturer's instruction manual, may cause harmful interference with radio communications. Operation of this equipment in a residential area is likely to cause harmful interference, in which case you will be required to correct the interference at your own expense.

California Best Management Practices Regulations for Perchlorate Materials: This Perchlorate warning applies only to products containing CR (Manganese Dioxide) Lithium coin cells. "Perchlorate Material-special handling may apply. See www.dtsc.ca.gov/hazardouswaste/perchlorate".



WARNING: This product can expose you to chemicals including lead, known to the State of California to cause cancer and birth defects or other reproductive harm. For more information, go to www.P65Warnings.ca.gov.

The products sold by Supermicro are not intended for and will not be used in life support systems, medical equipment, nuclear facilities or systems, aircraft, aircraft devices, aircraft/emergency communication devices or other critical systems whose failure to perform be reasonably expected to result in significant injury or loss of life or catastrophic property damage. Accordingly, Supermicro disclaims any and all liability, and should buyer use or sell such products for use in such ultra-hazardous applications, it does so entirely at its own risk. Furthermore, buyer agrees to fully indemnify, defend and hold Supermicro harmless for and against any and all claims, demands, actions, litigation, and proceedings of any kind arising out of or related to such ultra-hazardous use or sale.

Manual Revision 1.0

Release Date: November 04, 2020

mk

Unless you request and receive written permission from Super Micro Computer, Inc., you may not copy any part of this document. Information in this document is subject to change without notice. Other products and companies referred to herein are trademarks or registered trademarks of their respective companies or mark holders.

Copyright © 2020 by Super Micro Computer, Inc.
All rights reserved.

Printed in the United States of America

Preface

About this Manual

This manual is written for professional system integrators and PC technicians. It provides information for the installation and use of this chassis. Installation and maintenance should be performed by experienced technicians only.

Please refer to the CSE-LA15-W chassis specifications page on our website for updates on supported memory, processors and operating systems (<http://www.supermicro.com>).

Notes

For your system to work properly, please follow the links below to download all necessary drivers/utilities and the user's manual for your server.

- Supermicro product manuals: <http://www.supermicro.com/support/manuals/>
- Product drivers and utilities: <https://www.supermicro.com/wftp>
- Product safety info: http://www.supermicro.com/about/policies/safety_information.cfm

If you have any questions, please contact our support team at:
support@supermicro.com

This manual may be periodically updated without notice. Please check the Supermicro website for possible updates to the manual revision level.

Warnings

Special attention should be given to the following symbols used in this manual.



Warning! Indicates important information given to prevent equipment/property damage or personal injury.



Warning! Indicates high voltage may be encountered when performing a procedure.

Contents

Chapter 1 Introduction

1.1 Overview.....	7
1.2 Unpacking the System	7
1.3 Chassis Features	8
Control Panel	8
Chassis Front.....	9
Chassis Rear.....	10
1.4 Where to Get Replacement Components	11
1.5 Returning Merchandise for Service.....	11

Chapter 2 Chassis Installation

2.1 Overview.....	12
2.2 Preparing for Setup.....	12
Choosing a Setup Location.....	12
Rack Precautions	12
System/Chassis Precautions.....	13
Rack Mounting Considerations	13
Ambient Operating Temperature.....	13
Airflow	13
Mechanical Loading.....	13
Circuit Overloading	14
Reliable Ground.....	14
2.3 Installing the Rails	15
Identifying the Sections of the Rack Rails	15
Assembling the Inner Rails	15
Assembling the Outer Rails	16
Installing the Outer Rails onto the Rack.....	17
2.4 Installing the Server into a Rack.....	18
Installing the Chassis into a Telco Rack.....	19

Chapter 3 Maintenance and Component Installation

3.1 Removing Power	20
3.2 Accessing the System.....	21
3.3 Chassis Components	22

Storage Drives	22
Drive Carrier Indicators.....	22
3.5" Drive	24
System Cooling	25
System Fan Replacement	26
Checking the Server Air Flow	27
Overheating	27
Power Supply	28
Power Supply LEDs.....	28
PCI Expansion Cards	30

Contacting Supermicro

Headquarters

Address: Super Micro Computer, Inc.
980 Rock Ave.
San Jose, CA 95131 U.S.A.

Tel: +1 (408) 503-8000

Fax: +1 (408) 503-8008

Email: marketing@supermicro.com (General Information)
support@supermicro.com (Technical Support)

Website: www.supermicro.com

Europe

Address: Super Micro Computer B.V.
Het Sterrenbeeld 28, 5215 ML
's-Hertogenbosch, The Netherlands

Tel: +31 (0) 73-6400390

Fax: +31 (0) 73-6416525

Email: sales@supermicro.nl (General Information)
support@supermicro.nl (Technical Support)
rma@supermicro.nl (Customer Support)

Website: www.supermicro.nl

Asia-Pacific

Address: Super Micro Computer, Inc.
3F, No. 150, Jian 1st Rd.
Zhonghe Dist., New Taipei City 235
Taiwan (R.O.C)

Tel: +886-(2) 8226-3990

Fax: +886-(2) 8226-3992

Email: support@supermicro.com.tw

Website: www.supermicro.com.tw

Chapter 1

Introduction

1.1 Overview

This chapter provides a brief outline of the functions and features of the CSE-LA15-W chassis. Other materials and information about this product are available at www.supermicro.com.

1.2 Unpacking the System

Inspect the box the chassis was shipped in and note if it was damaged in any way. If any equipment appears damaged, please file a damage claim with the carrier who delivered it.

Decide on a suitable location for the rack unit that will hold the server. It should be situated in a clean, dust-free area that is well ventilated. Avoid areas where heat, electrical noise and electromagnetic fields are generated. It will also require a grounded AC power outlet nearby. Be sure to read the precautions and considerations noted in Appendix B.

1.3 Chassis Features

Control Panel

Power switches and status LEDs are located on the control panel on the front of the chassis.

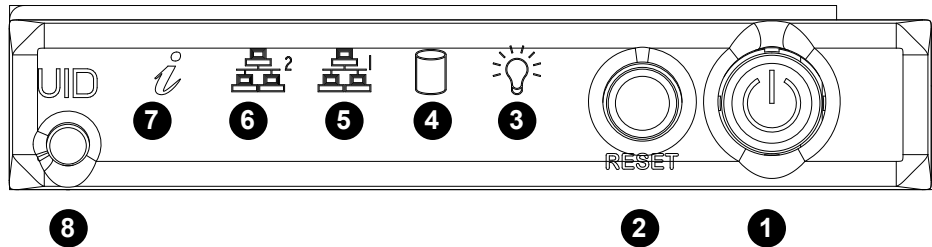

Figure 1-1. Control Panel

Control Panel Features		
Item	Features	Description
1	Power button	The main power switch applies or removes primary power from the power supply to the server but maintains standby power.
2	Reset	This button is used to 'hard reboot' the system
3	Power LED	Indicates power is being supplied to the system power supply units. This LED is illuminated when the system is operating normally.
4	HDD	Indicates activity on the hard drive when flashing.
5	NIC LED	Indicates network activity on LAN1 when flashing.
6	NIC LED	Indicates network activity on LAN2 when flashing.
7	Information LED	Alerts operator to several states, as noted in the table below.
8	UID button/LED	The unit identification (UID) button turns on or off the blue light function of the Information LED and a blue LED on the rear of the chassis. These are used to locate the server in large racks

Information LED	
Status	Description
Continuously on and red	An overheat condition has occurred. (This may be caused by cable congestion.)
Blinking red (1Hz)	Fan failure, check for an inoperative fan.
Blinking red (0.25Hz)	Power failure, check for a non-operational power supply.
Solid blue	UID has been activated locally to locate the server in a rack environment.
Blinking blue	UID has been activated using IPMI to locate the server in a rack environment.

Chassis Front

The illustration below shows the features included on the front of the chassis.

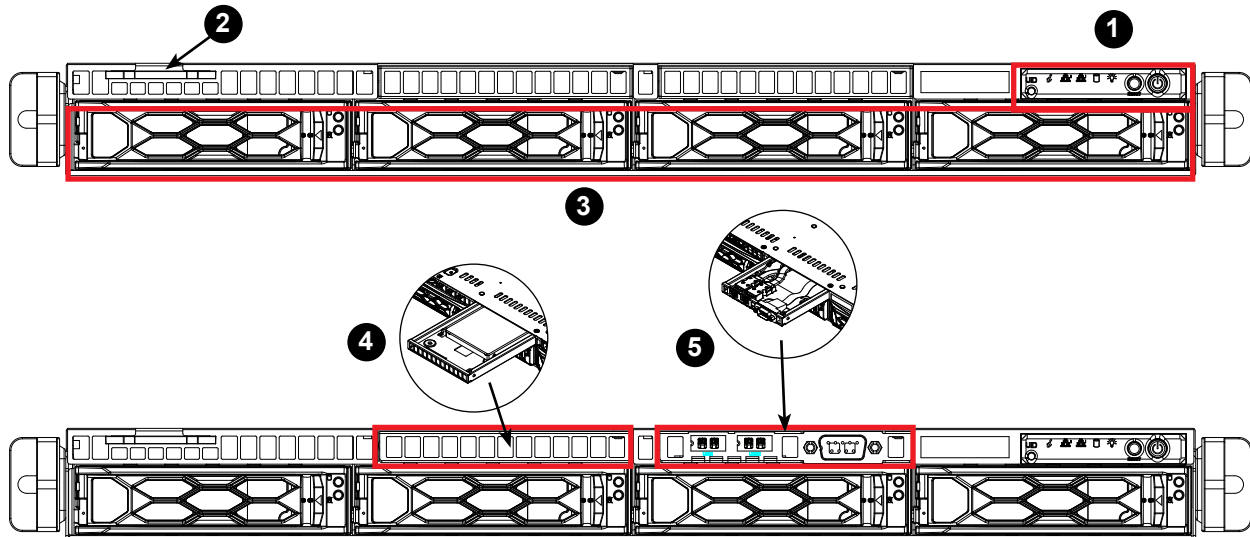

Figure 1-2. Front View

Chassis Front Features		
Item	Features	Description
1	Control Panel	Power buttons and status indicators
2	Service Tag	System service information tag
3	Storage Drive	Four 3.5" drive bays
4	2.5" HDD	Tray for optional 2.5" storage device
5	USB/COM Ports	Optional two front USB ports and one COM port

Chassis Rear

The illustration below shows the features included on the rear of the chassis. Power supply modules display status lights.

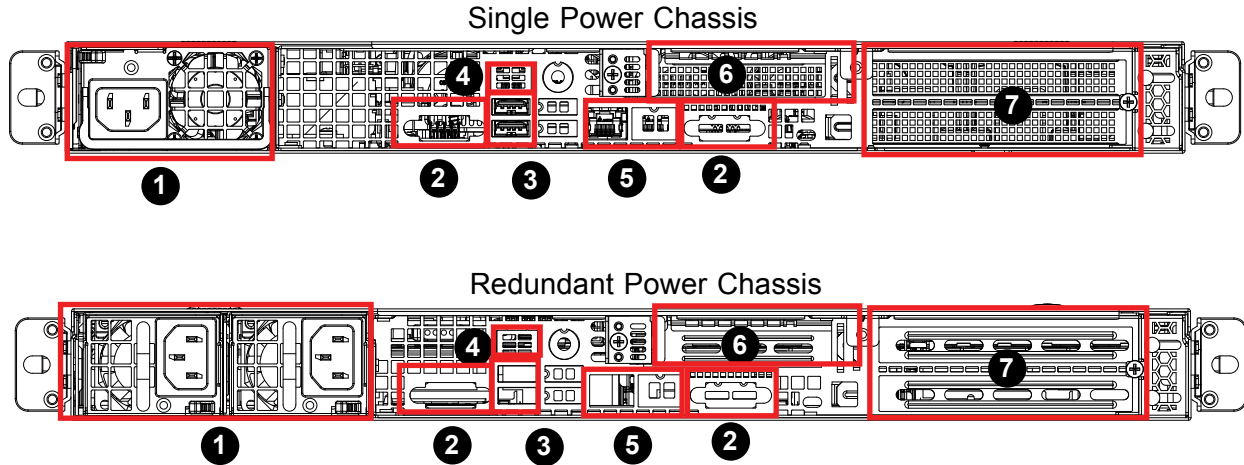

Figure 1-3. Rear View

Chassis Rear Features		
Item	Features	Description
1	Power Supply	1U Power Supply Single (563W) or Redundant (R504W)
2	COM, VGA	One COM port, one VGA port
3	USB	Up to four USB 3.0 ports
4	IPMI	One dedicated IPMI port
5	LAN	Up to two dedicated LAN ports
6	PCI	One PCI-Express slot on riser card (Low Profile, Half Length)
7	PCI	Two PCI-Express slot on riser card (Full Height, Half Length)

1.4 Where to Get Replacement Components

If you need replacement parts for your system, to ensure the highest level of professional service and technical support, purchase exclusively from our Supermicro Authorized Distributors/System Integrators/Resellers. A list can be found at: <http://www.supermicro.com>. Click the "Where to Buy" link.

1.5 Returning Merchandise for Service

A receipt or copy of your invoice marked with the date of purchase is required before any warranty service will be rendered. You can obtain service by calling your vendor for a Returned Merchandise Authorization (RMA) number. When returning to the manufacturer, the RMA number should be prominently displayed on the outside of the shipping carton, and mailed prepaid or hand-carried. Shipping and handling charges will be applied for all orders that must be mailed when service is complete.

For faster service, RMA authorizations may be requested online (<http://www.supermicro.com/support/rma/>).

Whenever possible, repack the chassis in the original Supermicro carton, using the original packaging material. If these are no longer available, be sure to pack the chassis securely, using packaging material to surround the chassis so that it does not shift within the carton and become damaged during shipping.

This warranty only covers normal consumer use and does not cover damages incurred in shipping or from failure due to the alteration, misuse, abuse or improper maintenance of products.

During the warranty period, contact your distributor first for any product problems.

Chapter 2

Chassis Installation

2.1 Overview

This chapter provides advice and instructions for mounting your chassis in a server rack. If your chassis is not already fully integrated with processors, system memory etc., refer to Chapter 4 for details on installing those specific components.

Caution: Electrostatic Discharge (ESD) can damage electronic components. To prevent such damage to PCBs (printed circuit boards), it is important to use a grounded wrist strap, handle all PCBs by their edges and keep them in anti-static bags when not in use.

2.2 Preparing for Setup

The box in which the chassis was shipped should include the rackmount hardware needed to install it into the rack. Please read this section in its entirety before you begin the installation.

Choosing a Setup Location

- The chassis should be situated in a clean, dust-free area that is well ventilated. Avoid areas where heat, electrical noise and electromagnetic fields are generated.
- Leave enough clearance in front of the rack so that you can open the front door completely (~25 inches) and approximately 30 inches of clearance in the back of the rack to allow sufficient space for airflow and access when servicing.
- This product should be installed only in a Restricted Access Location (dedicated equipment rooms, service closets, etc.).
- This product is not suitable for use with visual display workplace devices according to §2 of the German Ordinance for Work with Visual Display Units.

Rack Precautions

- Ensure that the leveling jacks on the bottom of the rack are extended to the floor so that the full weight of the rack rests on them.

- In single rack installations, stabilizers should be attached to the rack. In multiple rack installations, the racks should be coupled together.
- Always make sure the rack is stable before extending a server or other component from the rack.
- You should extend only one server or component at a time - extending two or more simultaneously may cause the rack to become unstable.

System/Chassis Precautions

- Review the electrical and general safety precautions in Appendix B.
- Determine the placement of each component in the rack *before* you install the rails.
- Install the heaviest server components at the bottom of the rack first and then work your way up.
- Use a regulating uninterruptible power supply (UPS) to protect the server from power surges and voltage spikes and to keep your system operating in case of a power failure.
- Allow any drives and power supply modules to cool before touching them.
- When not servicing, always keep the front door of the rack and all covers/panels on the servers closed to maintain proper cooling.

Rack Mounting Considerations

Ambient Operating Temperature

If installed in a closed or multi-unit rack assembly, the ambient operating temperature of the rack environment may be greater than the room's ambient temperature. Therefore, consideration should be given to installing the equipment in an environment compatible with the manufacturer's maximum rated ambient temperature (TMRA).

Airflow

Equipment should be mounted into a rack so that the amount of airflow required for safe operation is not compromised.

Mechanical Loading

Equipment should be mounted into a rack so that a hazardous condition does not arise due to uneven mechanical loading.

Circuit Overloading

Consideration should be given to the connection of the equipment to the power supply circuitry and the effect that any possible overloading of circuits might have on overcurrent protection and power supply wiring. Appropriate consideration of equipment nameplate ratings should be used when addressing this concern.

Reliable Ground

A reliable ground must be maintained at all times. To ensure this, the rack itself should be grounded. Particular attention should be given to power supply connections other than the direct connections to the branch circuit (i.e. the use of power strips, etc.).



To prevent bodily injury when mounting or servicing this unit in a rack, you must take special precautions to ensure that the system remains stable. The following guidelines are provided to ensure your safety:

- This unit should be mounted at the bottom of the rack if it is the only unit in the rack.
- When mounting this unit in a partially filled rack, load the rack from the bottom to the top with the heaviest component at the bottom of the rack.
- If the rack is provided with stabilizing devices, install the stabilizers before mounting or servicing the unit in the rack.

2.3 Installing the Rails

This section provides information on installing the chassis into a rack unit with the rails provided. There are a variety of rack units on the market, which may mean that the assembly procedure differs slightly. You should also refer to the installation instructions that came with the rack unit you are using.

These rails fit a rack between 26" and 33.05" deep.

Identifying the Sections of the Rack Rails

The chassis package includes a rail set that includes the inner and outer rail pieces that attaches to the rack.

Assembling the Inner Rails

Each right and left inner rail assembly comes in two sections, a front and an extension to support the entire length of the chassis. Install the inner rails as shown in the following illustration:

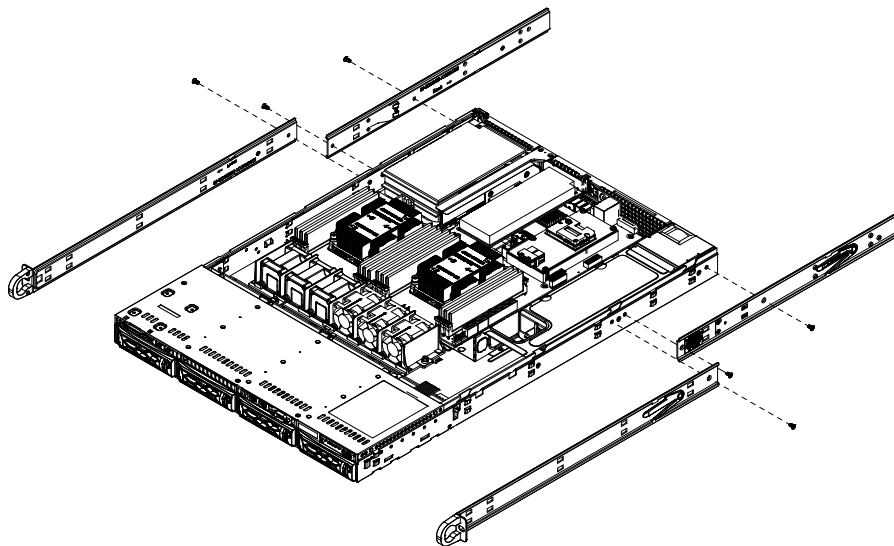

Figure 2-1. Assembling the Inner Rails



Warning: do not pick up the server with the front handles. They are designed to pull the system from a rack only.

Assembling the Outer Rails

Each outer rail comes in two sections that must be assembled before mounting onto the rack.

Assembling the Outer Rails

1. Identify the left and right outer rails by examining the ends, which bend outward. Match the left front outer rail with the left rear outer rail and the same for the right rails.
2. Align the round post in the rear rail (B) with the round hole at the end of the slot in the front rail (A), and slide the front section into the rear section.

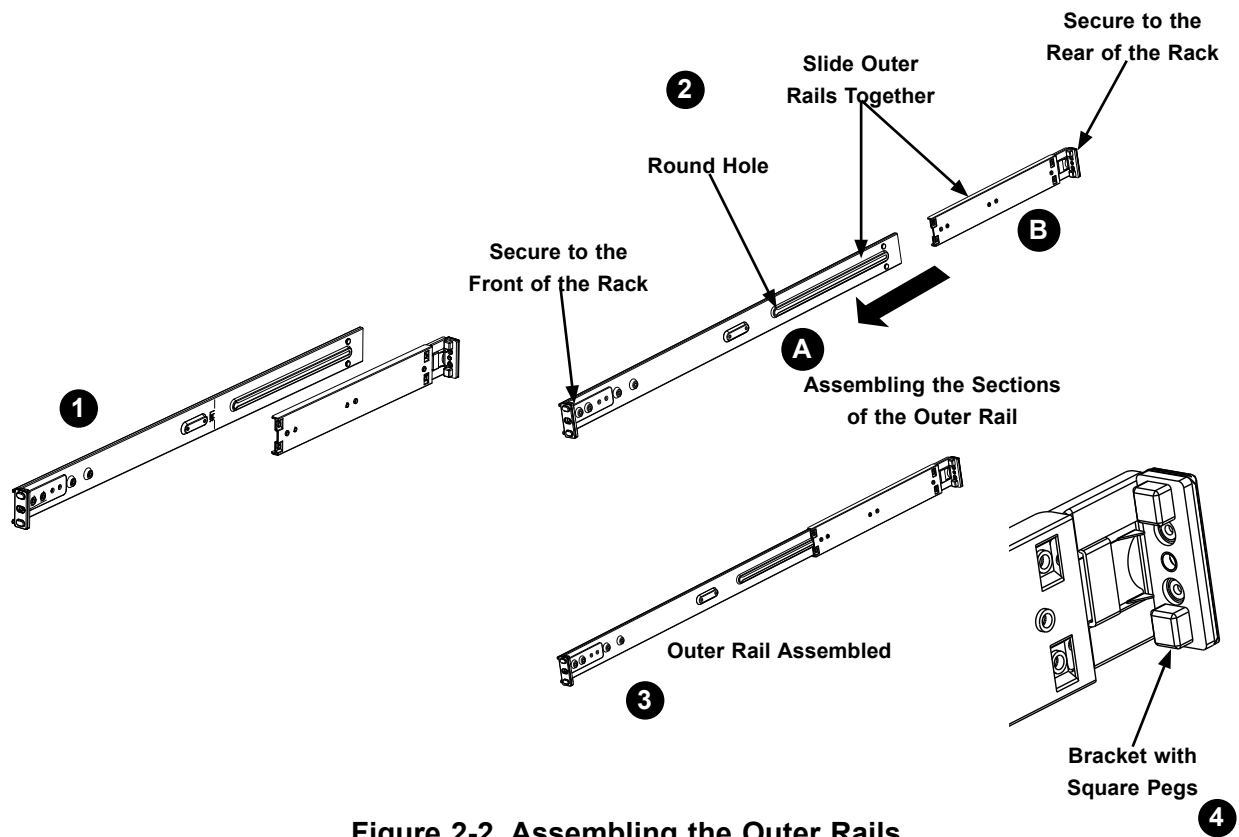

Figure 2-2. Assembling the Outer Rails



Slide rail mounted equipment is not to be used as a shelf or a work space.

Installing the Outer Rails onto the Rack

Each end of the assembled outer rail includes a bracket with square pegs to fit into your rack holes. If you have an older rack with round holes, these brackets must be removed, and you must use screws to secure the rail to the rack.

Outer Rail Installation

1. Align the square pegs on the front end of the rail with the square holes on the front of the rack (C). Push the rail into the rack until the quick release bracket snaps into place, securing the rail to the rack. Keep the rail horizontal.
2. Adjust the rail to reach just past the full depth of your rack.
3. Align the square pegs on the rear end of the rail to the holes on the rack (D) and push the rail into the rack until the quick release bracket snaps into place, securing the rail to the rack.
4. Repeat the procedure for the other outer rail assembly.

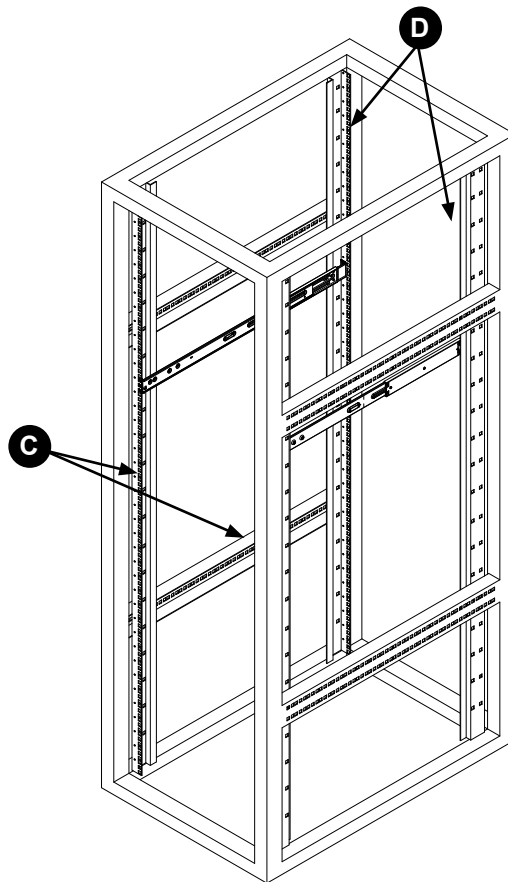

Figure 2-3. Installing the Outer Rails to the Rack

Note: Figure is for illustrative purposes only. Always install servers to the bottom of a rack first.



Warning: Stability hazard. The rack stabilizing mechanism must be in place, or the rack must be bolted to the floor before you slide the unit out for servicing. Failure to stabilize the rack can cause the rack to tip over.

2.4 Installing the Server into a Rack

You should now have rails attached to both the chassis and the rack. The next step is to install the server into the rack.

Installing the Chassis into a Rack

1. Confirm that the outer rails are installed on the rack.
2. Align the chassis with the front of the out rails on the rack.
3. Slide the chassis rails into the rack rails, keeping the pressure even on both sides (you may have to depress the locking tabs when inserting). When the server has been pushed completely into the rack, you should hear the locking tabs click into position.
4. (Optional) Insert and tighten the thumbscrews that hold the front of the server to the rack.

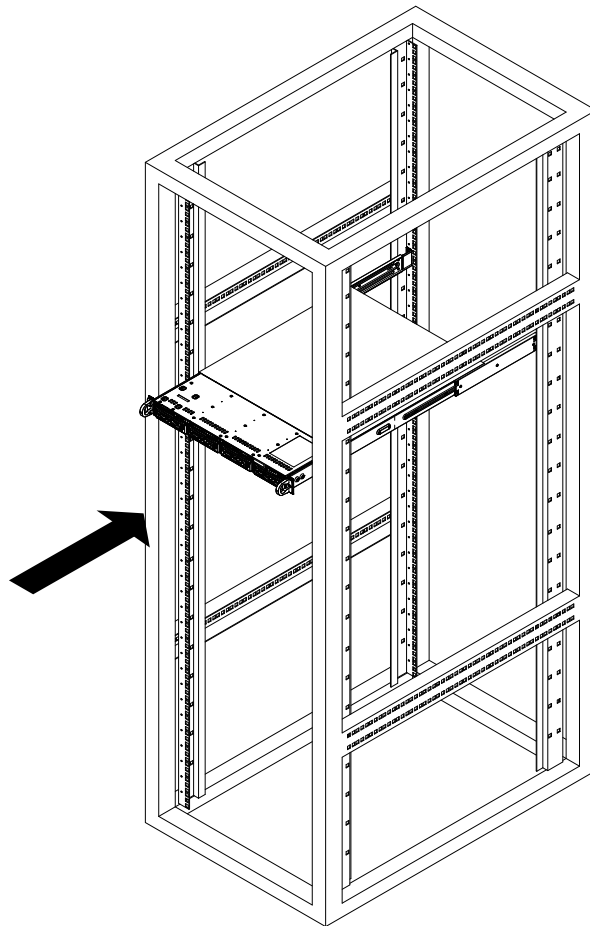

Figure 2-4. Installing the Server into a Rack

Note: Figure is for illustrative purposes only. Always install servers to the bottom of a rack first.

Installing the Chassis into a Telco Rack

To install the chassis into a Telco or post-style rack, use two L-shaped brackets on either side of the chassis (four total). First, determine how far the server will extend out the front of the rack. Larger chassis should be positioned to balance the weight between front and back. If a bezel is included on your server, remove it. Then attach the two front brackets to each side of the chassis, then the two rear brackets positioned with just enough space to accommodate the width of the telco rack. Finish by sliding the chassis into the rack and tightening the brackets to the rack.

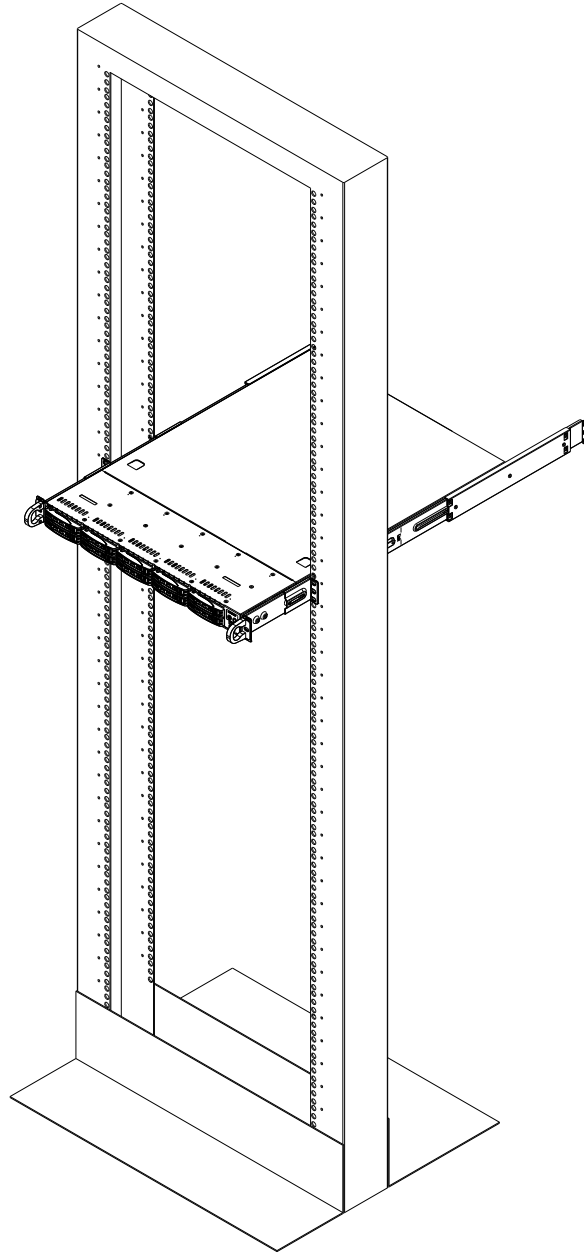

Figure 2-5. Installing the Server into a Telco Rack

Note: Figure is for illustrative purposes only. Always install servers to the bottom of a rack first.

Chapter 3

Maintenance and Component Installation

This chapter provides instructions on installing and replacing main system components. To prevent compatibility issues, only use components that match the specifications and/or part numbers given.

Installation or replacement of most components require that power first be removed from the system. Please follow the procedures given in each section.

3.1 Removing Power

Use the following procedure to ensure that power has been removed from the system. This step is necessary when removing or installing non hot-swap components or when replacing a non-redundant power supply.

1. Use the operating system to power down the system.
2. After the system has completely shut-down, disconnect the AC power cord(s) from the power strip or outlet. (If your system has more than one power supply, remove the AC power cords from all power supply modules.)
3. Disconnect the power cord(s) from the power supply module(s).

3.2 Accessing the System

The SCLA15 chassis features a removable top cover, which allows easy access to the inside of the chassis.

Removing the Top Cover

1. Remove screws #1, and #2 as shown below.
2. Slide cover towards the rear, as show in #3 then lift the top cover up in #4.

Check that all ventilation openings on the top cover and the top of the chassis are clear and unobstructed.

Caution: Except for short periods of time, do not operate the server without the cover in place. The chassis cover must be in place to allow for proper airflow and to prevent overheating.

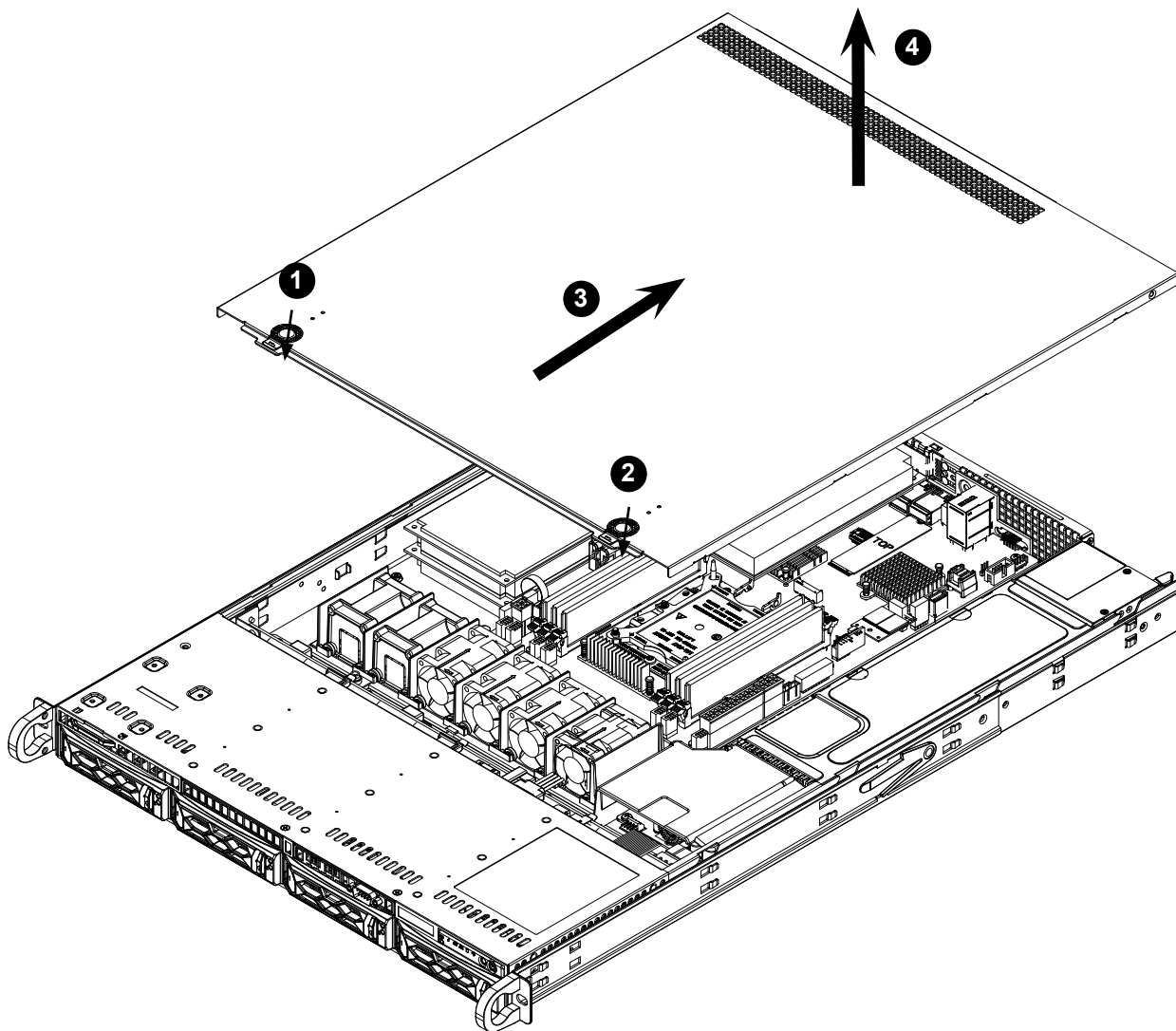

Figure 3-1. Removing the Chassis Cover

3.3 Chassis Components

This section provides instructions on installing and replacing system components. To assure compatibility, only use components that match the specifications or part numbers given.

Storage Drives

The system supports four 3.5" tool-less storage drives. These are SAS3/SATA.

Note: Enterprise level hard disk drives are recommended for use in Supermicro chassis and servers. For information on recommended HDDs, visit the Supermicro website product pages at <https://www.supermicro.com/products/nfo/Ultra.cfm>.

The drives are mounted in toolless drive carriers that simplify their removal from the chassis. These carriers also help promote proper airflow.

Drive Carrier Indicators

Each drive carrier has two LED indicators: an activity indicator and a status indicator. For RAID configurations using a controller, the meaning of the status indicator is described in the table below. For OS RAID or non-RAID configurations, some LED indications are not supported, such as hot spare.

Drive Carrier LED Indicators			
	Color	Blinking Pattern	Behavior for Device
Activity LED	Blue	Solid On	SATA/SAS/NVMe drive installed
	Blue	Blinking	I/O activity
Status LED	Red	Solid On	Failure of drive with RSTe support
	Red	Blinking at 1 Hz	Rebuild drive with RSTe support
	Red	Blinking with two blinks and one stop at 1 Hz	Hot spare for drive with RSTe support <i>(not supported in VMD mode)</i>
	Red	On for five seconds, then off	Power on for drive with RSTe support
	Red	Blinking at 4 Hz	Identify drive with RSTe support
	Green	Solid On	Safe to remove NVMe device <i>(not supported in VMD mode)</i>
	Amber	Blinking at 1 Hz	Attention state—do not remove NVMe device <i>(not supported in VMD mode)</i>

Removing a Hot-Swap Drive Carrier from the Chassis

1. Press the release latch towards the left on the drive carrier, which will release the drive carrier handle.
2. Use the drive carrier handle to pull the drive out of the chassis.

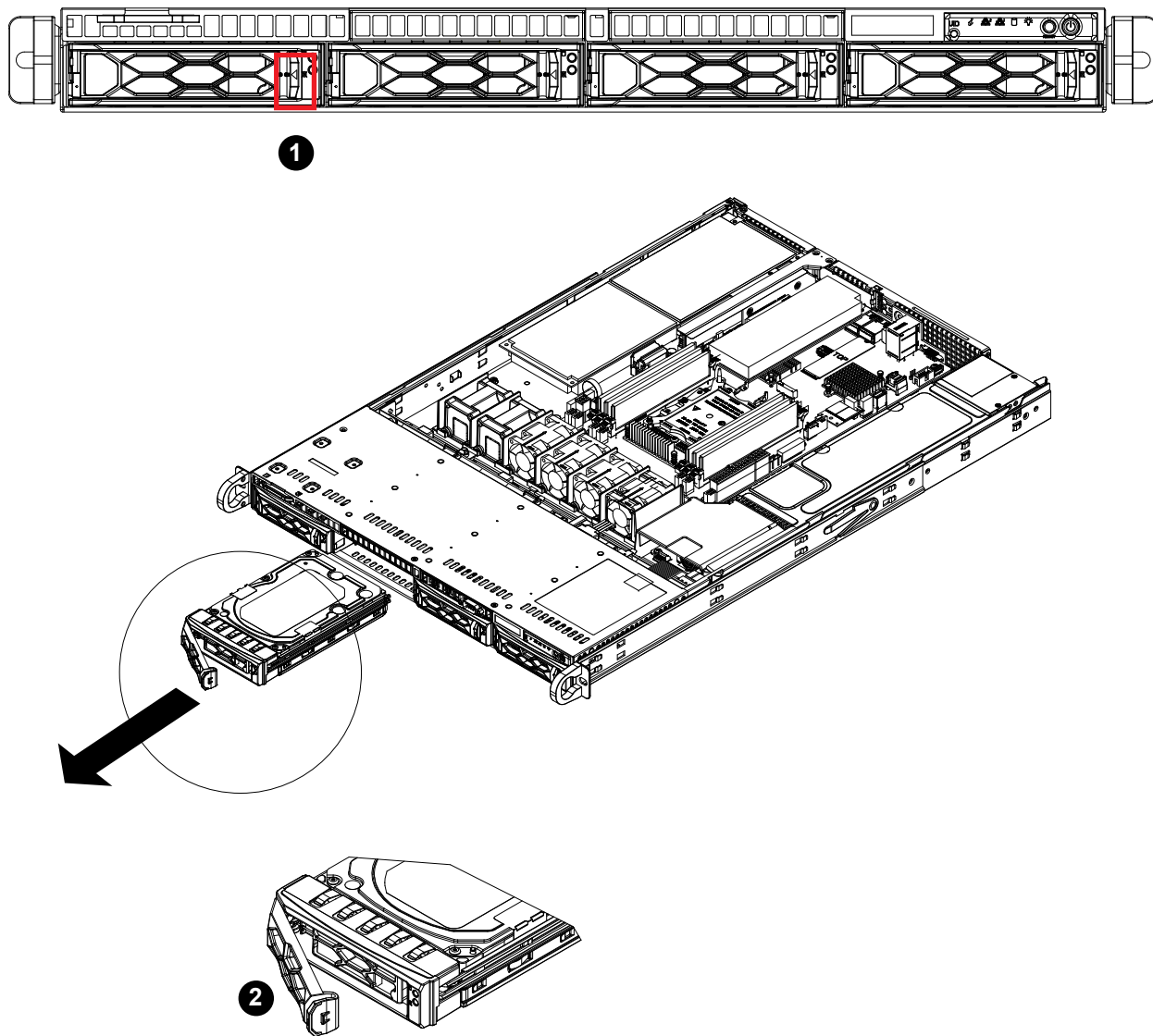

Figure 3-2. Removing a Drive Carrier

Installing a "tool-less" 3.5" Hard Drive (No screws needed)

1. Place the hard drive carrier on a flat surface.
2. Insert a 3.5" hard drive in an angle into the carrier so that the mounting screw holes on the right side of the drive align with two stubs in the drive carrier. Insert this side into the drive carrier first, then push the other side into the drive carrier completely.
3. The drive should be already snug and secure in the drive tray. However as an option, a screw may be installed underneath, included with the hard drive.
4. Use the open handle of the drive carrier to insert the drive carrier into the open drive bay. Secure the drive carrier into the drive bay by closing the drive carrier handle.

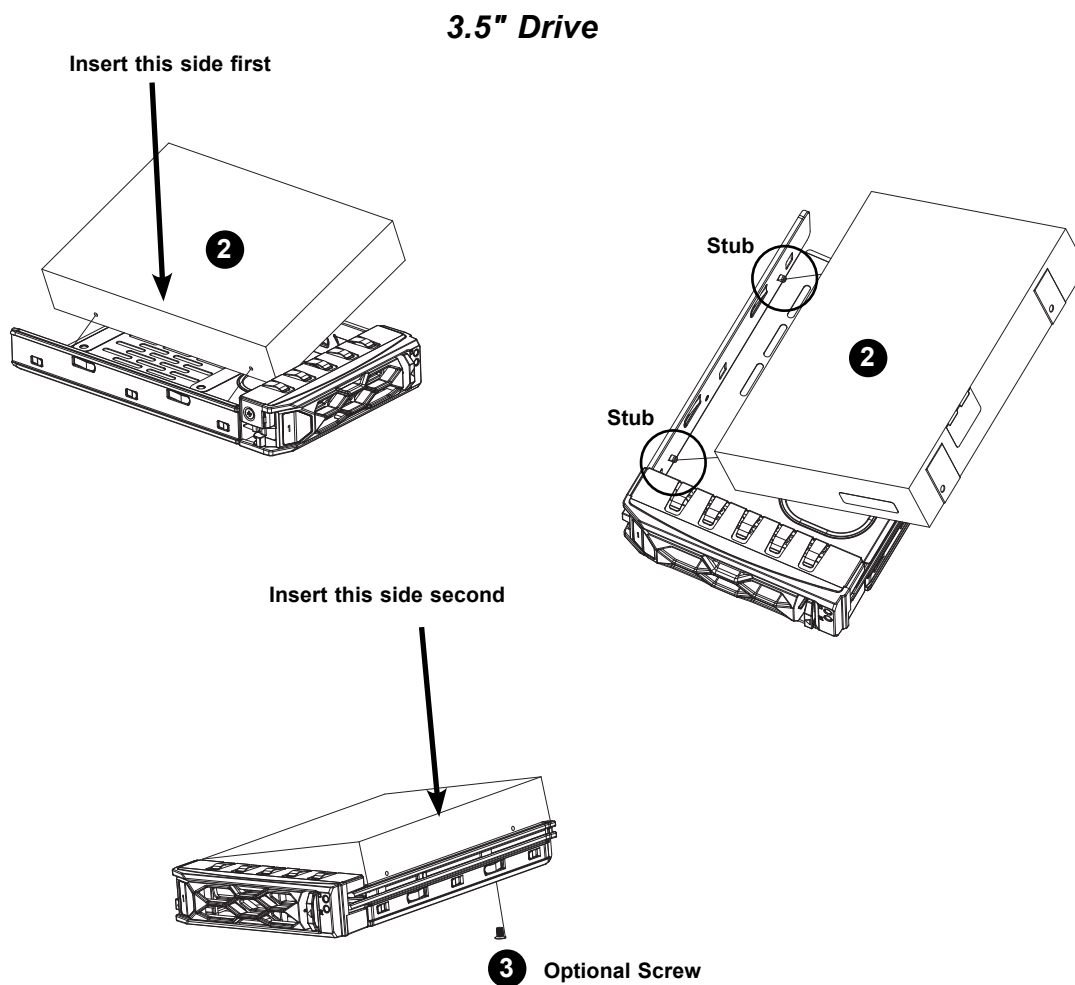

Figure 3-3. Installing a 3.5" Hard Drive

System Cooling

There are three 4-cm counter-rotating fans (with option for three more) that provide cooling for the system. Each fan unit is actually made up of two fans joined back-to-back, which rotate in opposite directions. This counter-rotating action generates exceptional airflow and works to dampen vibration levels. These fans are secured to the chassis without using any screws, for easy replacement or upgrades. Simply drop them in, plug the cable and secure the chassis cover.

Make sure the chassis top cover makes a good seal so the cooling air circulates properly through the chassis.

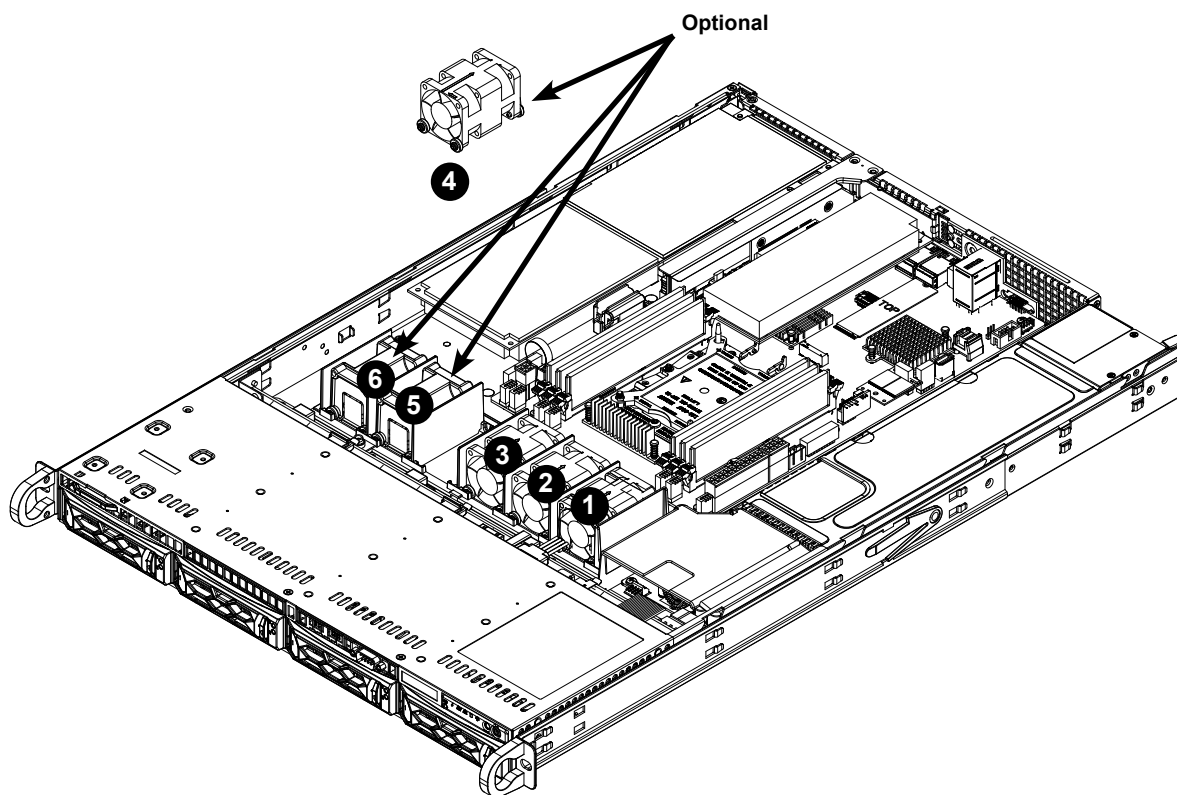

Figure 3-4. Fan Positions

System Fan Replacement

Fan speed is controlled by IPMI depending on the system temperature. If a fan fails, the remaining fans will ramp up to full speed. The system can continue to run with a failed fan. Replace any failed fan at your earliest convenience with the same model. Failed fans can be identified through the BIOS. The fan numbers are printed on the floor of the chassis.

Changing a System Fan

1. If necessary, open the chassis while the system is running to determine which fan has failed. Never run the server for an extended period of time with the chassis cover open.
2. Power down the system as described in section 3.1.
3. Unplug the fan cable from the serverboard and remove the failed fan from the chassis. The fan is designed to be pulled out, there are no screws.
4. Replace the failed fan with an identical 4cm fan, available from Supermicro.
5. Push the new fan into the vacant space in the housing while making sure the arrows on the top of the fan (indicating air direction) point in the same direction as the arrows on the other fans.
6. Reposition the fan housing back over the two mounting posts in the system, then reconnect the fan wires to the same fan headers on the serverboard.
7. Power up the system and check that the fan is working properly and that the LED on the control panel has turned off. Finish by replacing the chassis cover.

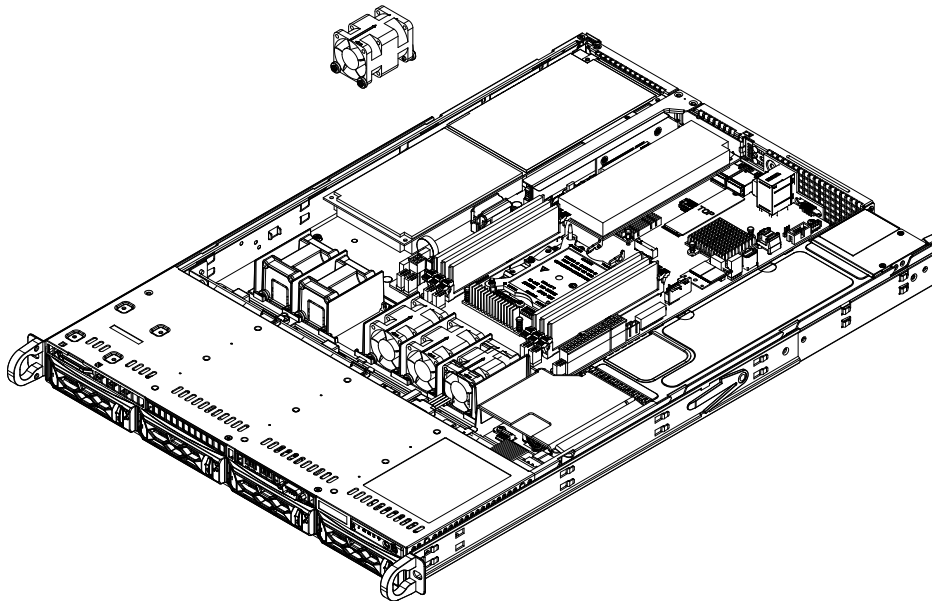

3-5. Fans in Housing

Checking the Server Air Flow

- Make sure there are no objects to obstruct airflow in and out of the server.
- Do not operate the server without drives or drive carriers in the drive bays.
- Use only recommended server parts.
- Make sure no wires or foreign objects obstruct air flow through the chassis. Pull all excess cabling out of the airflow path or use shorter cables.

The control panel LEDs display system heat status. See “Control Panel” in Chapter 1 for details.

Overheating

There are several possible responses if the system overheats.

Overheat Temperature Setting

Some backplanes allow the overheat temperature to be set at 45, 50, or 55 by changing a jumper setting. For more information, consult the backplane user manual at www.supermicro.com. (Click Support, then the Manuals link.)

Responses

If the server overheats:

1. Use the LEDs to determine the nature of the overheating condition.
2. Confirm that the chassis covers are installed properly.
3. Make sure all fans are present and operating normally.
4. Check the routing of the cables.
5. Verify that the heatsinks are installed properly.

Power Supply

The power supply is auto-switching capable. This feature enables them to automatically sense the input voltage and operate at a 100-120v or 180-240v.

Power Supply LEDs

On the rear of the power supply module, an LED displays the status.

- **Solid Green:** When illuminated, indicates that the power supply is on.
- **Blinking Green:** When blinking, indicates that the power supply is plugged in and turned off by the system.
- **Blinking Amber:** When blinking, indicates that the power supply has a warning condition and continues to operate.
- **Solid Amber:** When illuminated, indicates that the power supply is plugged in, and is in an abnormal state. The system might need service. Please contact Supermicro technical support.

Changing the Power Supply Module (single):

1. Unplug the AC cord from the module to be replaced.
2. Remove the top cover of the chassis.
3. Remove the two screws securing the power supply as shown below..
4. The power supply should slide out. Replace with a working unit.
5. Replace the chassis cover and plug the AC power cord back into the module.

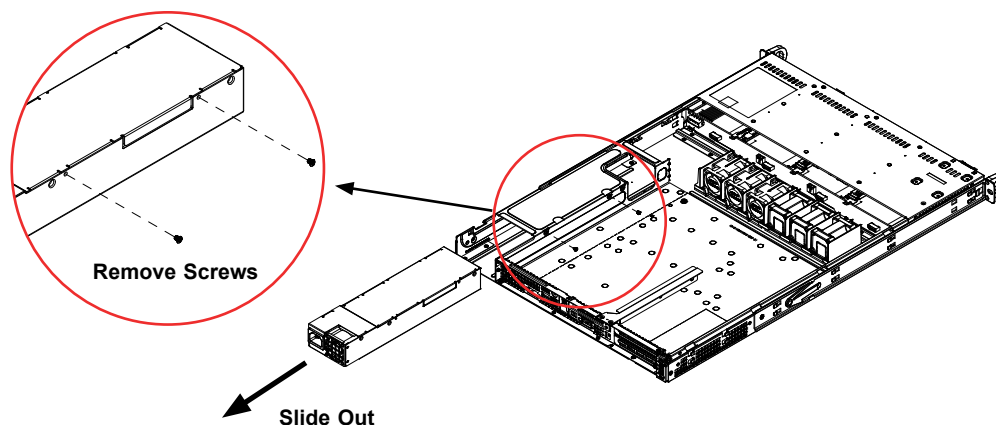
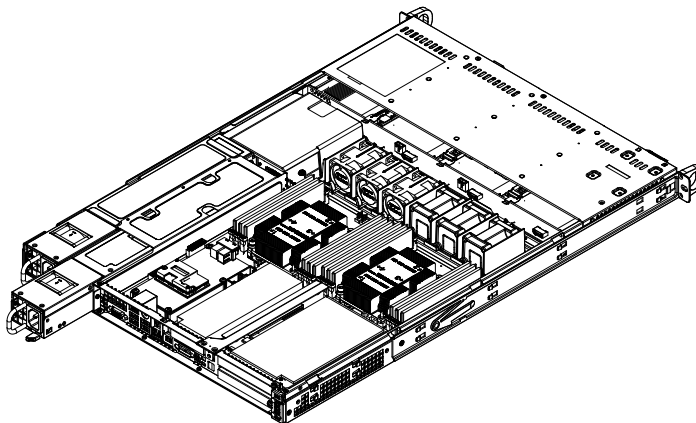

Figure 3-6. Replacing the Power Supply

Changing the Power Supply Module (redundant):

6. If you are replacing only one power supply, there is no need to power down the system. If both power supplies need to be replaced, then a power-down is required and unplug the AC cord from the module to be replaced.



7. On the back of the module, push the release lever to the right, as illustrated in the previous illustration.
8. Pull the module out using the handle.
9. Push the new power supply module into the power bay until it clicks. Replace with the same model.
10. Plug the AC power cord back into the module.

PCI Expansion Cards

The system accepts low profile cards, mounted on a riser card and riser bracket. See the table below for the different supported configurations.

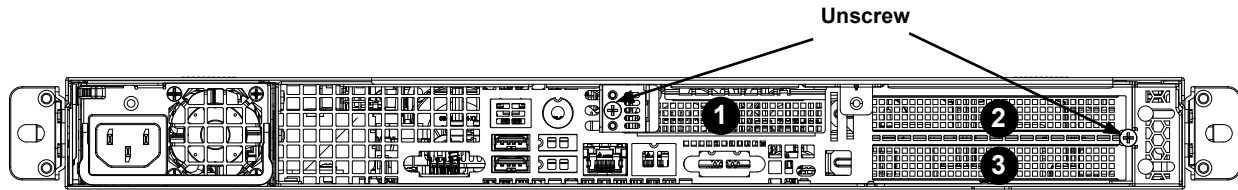

Figure 3-7. PCI Expansion Card Chassis Slots

Expansion Card Configurations	
Slot	Mechanical
1	Low profile, half length
2	Full height, half length
3	Full height, half length

Full height = 4.2", Low profile = 2.5",
Full length = 10.5", Half length = 6.6"

Installing an Expansion Card

1. Power down the system as described in section 3.1 and remove the cover.
2. Remove the bracket and sections of the chassis in the rear.

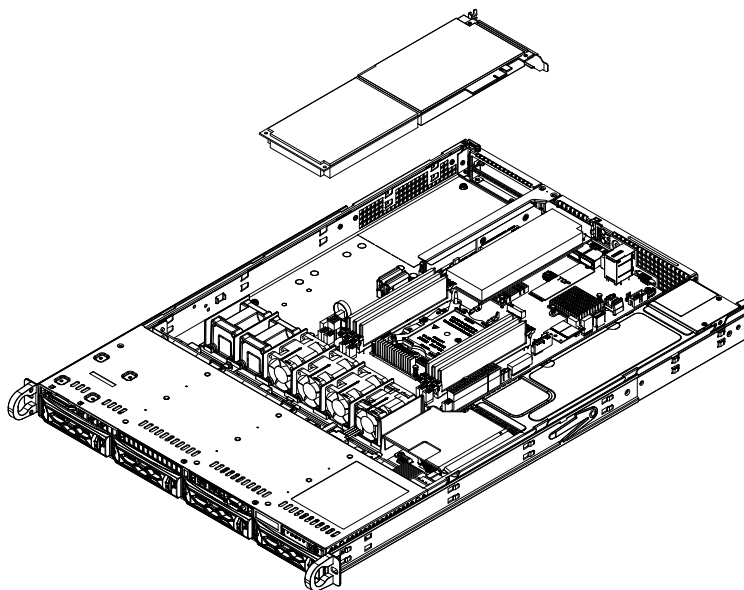

Figure 3-8. Low Profile Riser Card Bracket and Expansion Slots

3. If necessary, attach the riser card to the riser card bracket using screws.
4. Insert the expansion card into a slot on the riser card while aligning the expansion card back plate with the open slot in the rear of the chassis.
5. Insert the riser card into the motherboard expansion slot while aligning the riser card bracket with the rear of the chassis.
6. If necessary, connect power cables to one of the 8-pin power connectors on the motherboard.

Installing a Low Profile Internal Expansion Card

1. Remove the cover.
2. Locate the mounting bracket in the accessories box. Mount the bracket to hold the low profile expansion card onto the Ultra riser card.
3. Insert the card into the expansion slot on the Ultra riser card and secure it to the bracket.

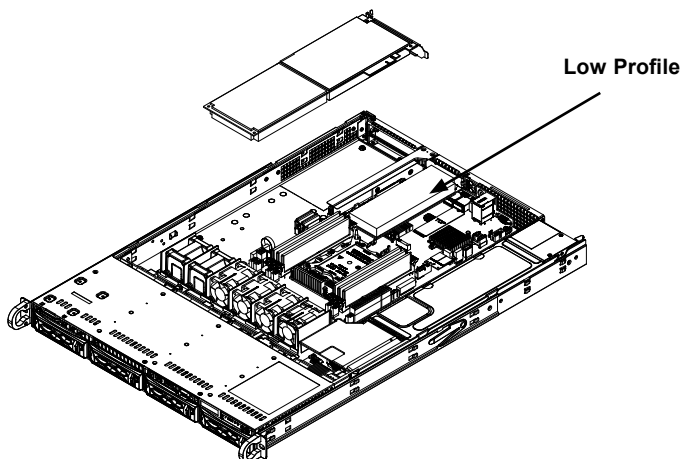

Figure 3-9. Bracket for Mounting a Low Profile Internal Expansion Card